



かん字のれんしゅう①「川・人」

なまえ



ゆっくりていねいに、わくの
中なかにかきましよう。

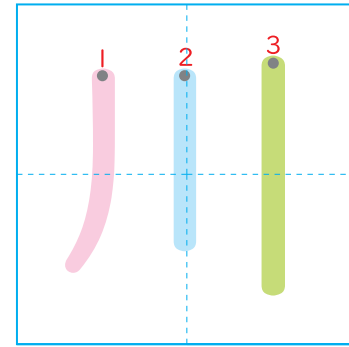

きれいな

川かわ。

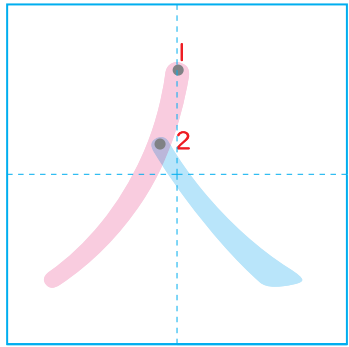
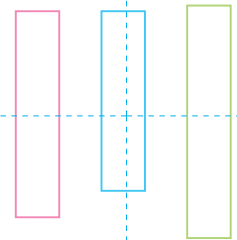
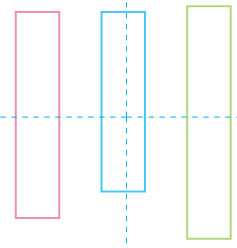
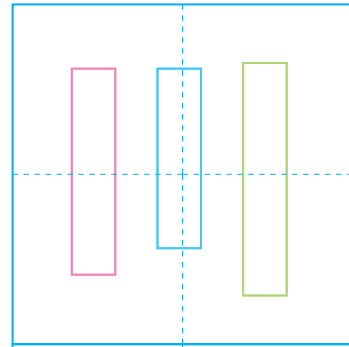
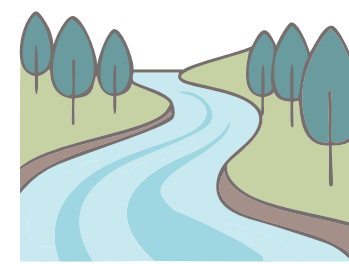

人ひとが
いる。
三人さんにんの
ともだち。

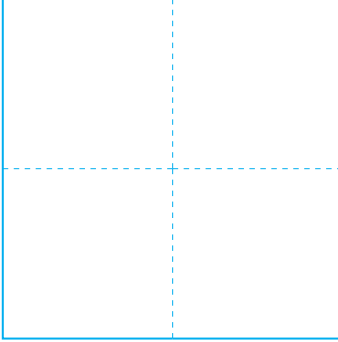
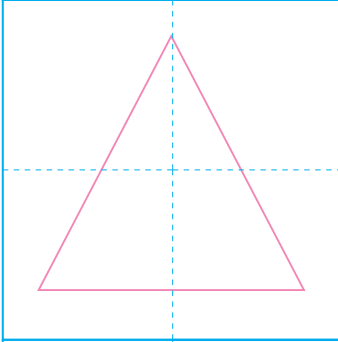
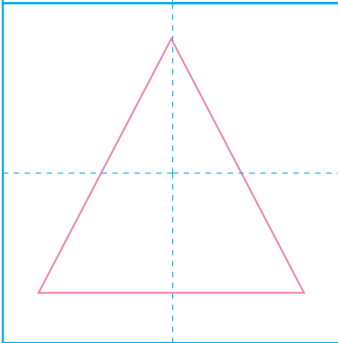
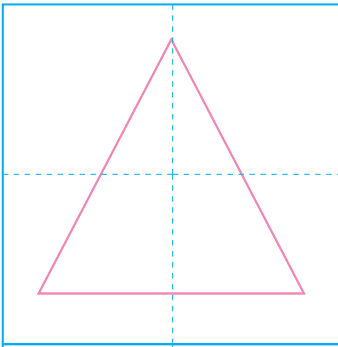
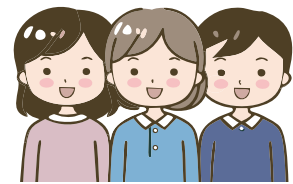



かん字のれんしゅう②「山・木」

なまえ



ゆっくりていねいに、わくの
中に
かきましょう。

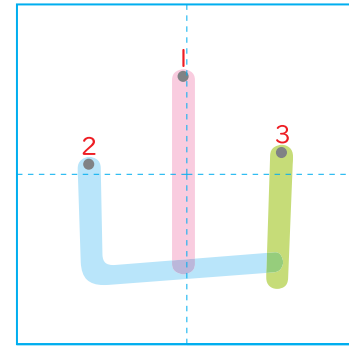

山にのぼる。
ふじ山

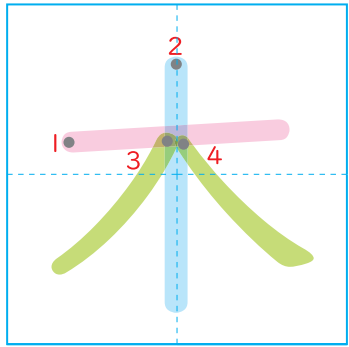
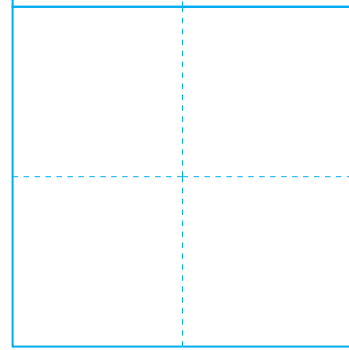
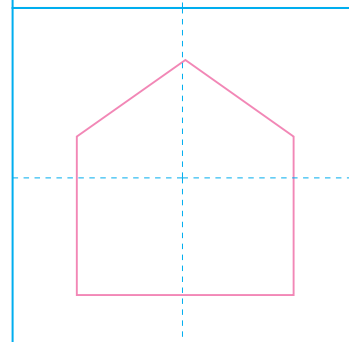
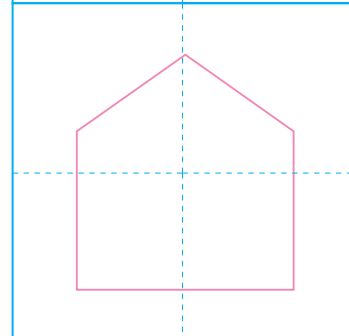
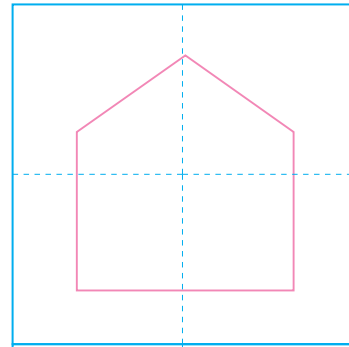
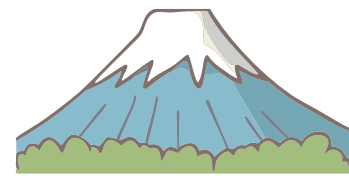

大きい木。
木よう日

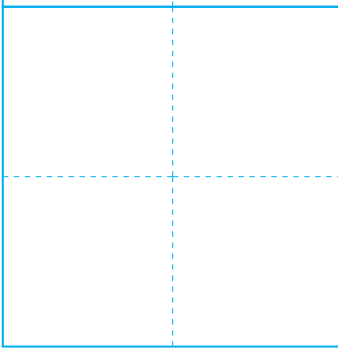
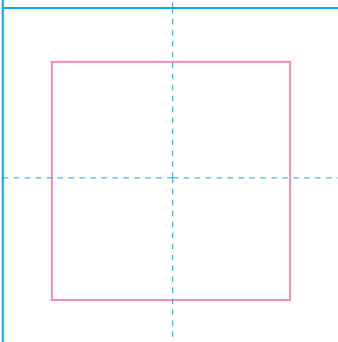
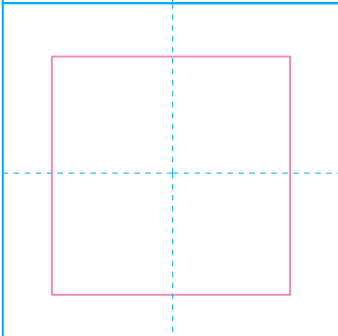
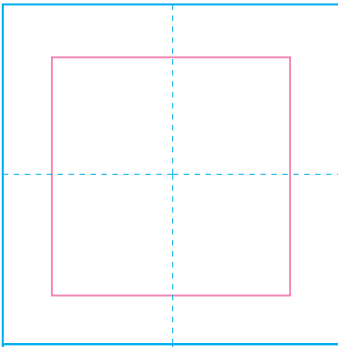
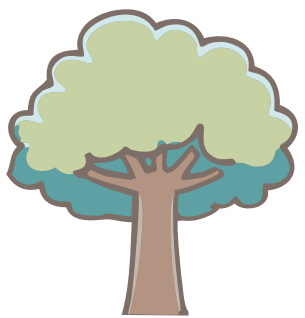

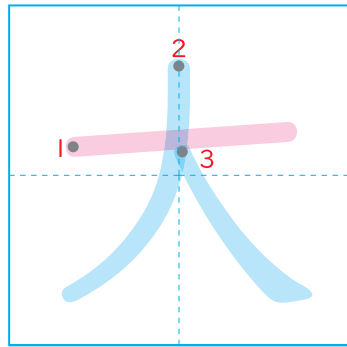
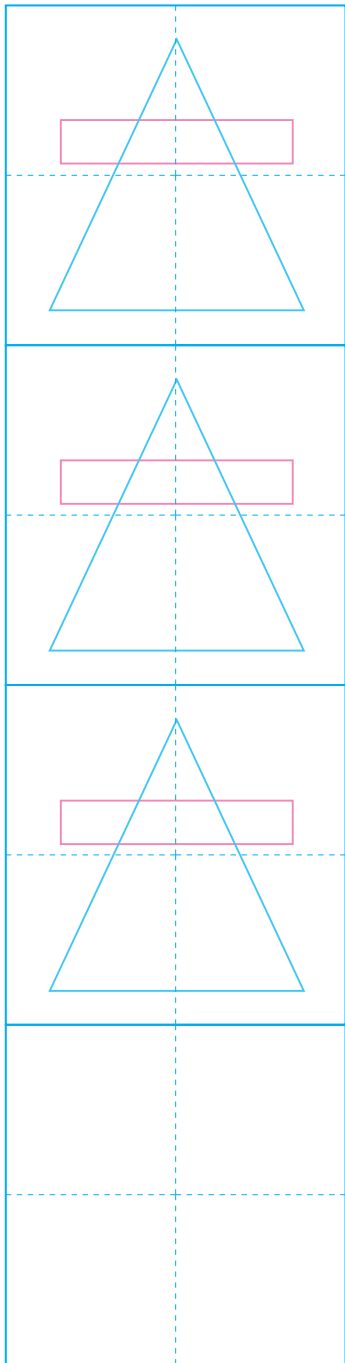

・ だい 大
 ・ おお 大
 ・ き 木。

大すきな
 いろ。
 大きい
 木。

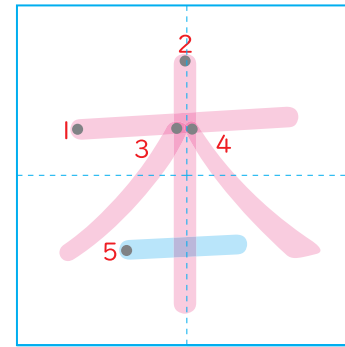
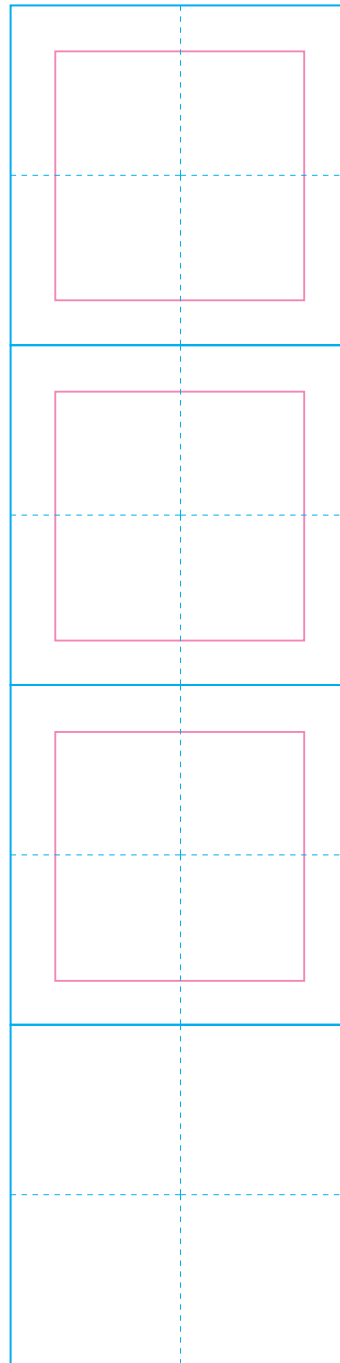
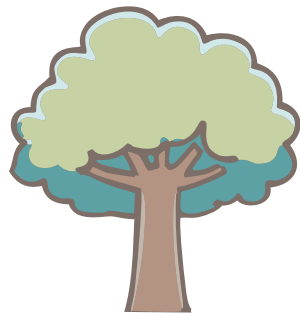

・ ほん 本
 を
 よむ。



ゆっくり
 ていねいに、
 わくの
 中なかに
 かきましょう。



かん字じの
 れんしゅう③
 「本・大」

なまえ

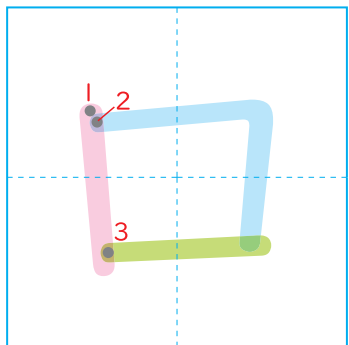

・
口^{くち}
を

あける。



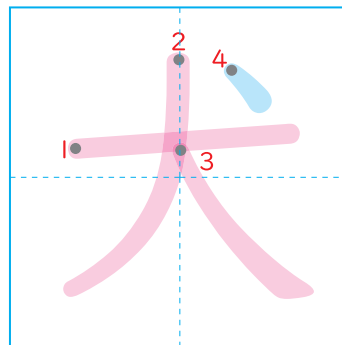

・
白^{しろ}
い

犬^{いぬ}
。

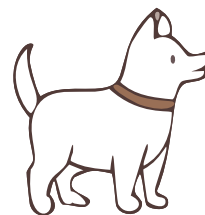

ゆっくり
ていねいに、
わくの
中^{なか}に
かきましょう。



かん字^じの
れんしゅう④
「犬・口」

なまえ



かん字のれんしゅう⑤ 「石・中」

なまえ



ゆっくり ていねいに、わくの 中^{なか}に かきましよう。

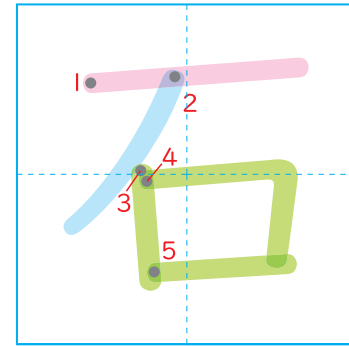

かたい 石^{いし}。

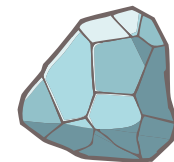

Four empty boxes for practicing writing the kanji '石' (stone). Each box is divided into four quadrants by a vertical and a horizontal dashed line.

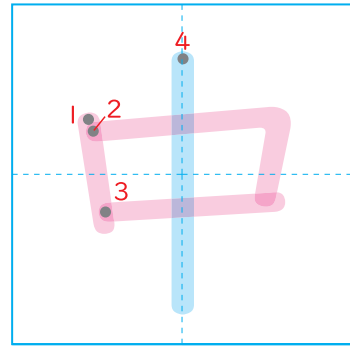

はこの 中^{なか}。 すいちゆう 水 中^{すいちゆう}の さかな。

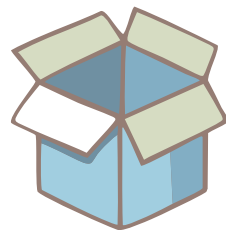

Four empty boxes for practicing writing the kanji '中' (middle). Each box is divided into four quadrants by a vertical and a horizontal dashed line.



かん字のれんしゅう⑥「虫・足」

なまえ



ゆっくりていねいに、わくの
中なかにかきましよう。

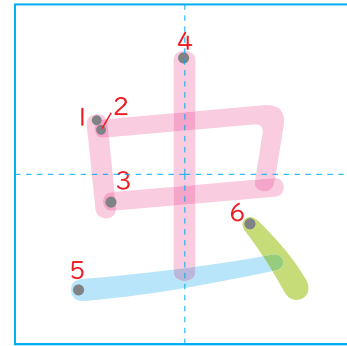

いろいろな
虫むし。

こん虫ちゅうを
さがす。

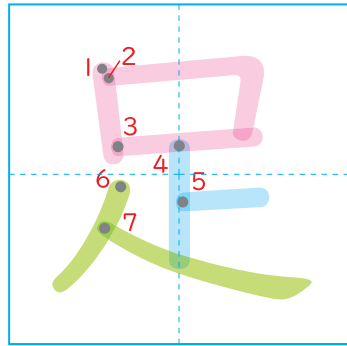
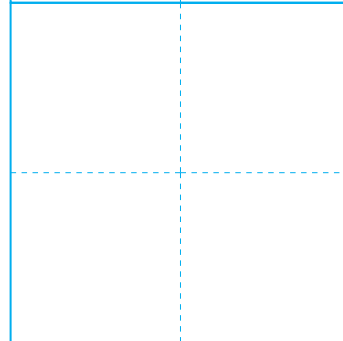
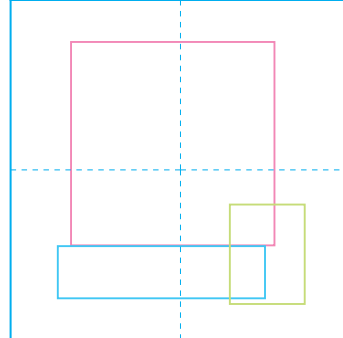
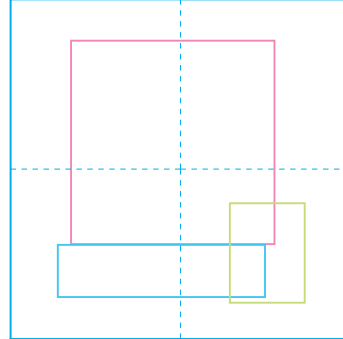
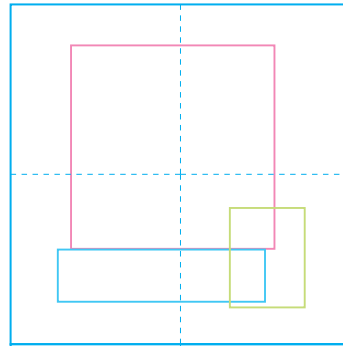
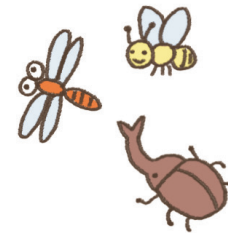

足あしの
むく。

えん足そくに
いく。

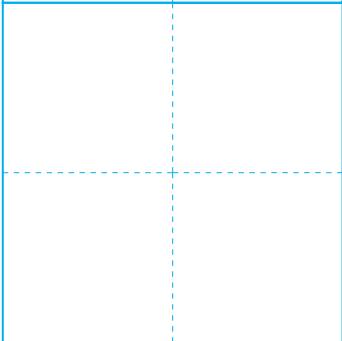
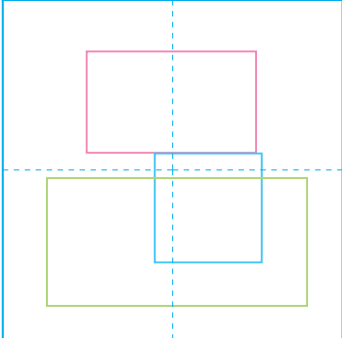
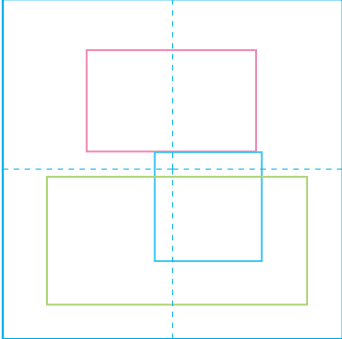
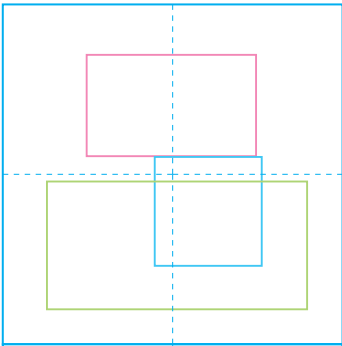



かん字のれんしゅう⑦「日・白」

なまえ



ゆっくりていねいに、わくの
中に
かきましょう。

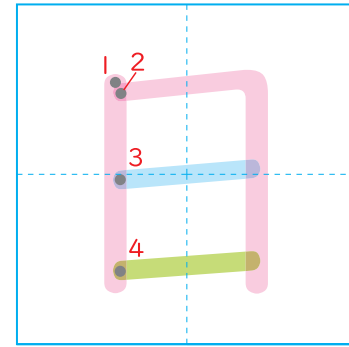

• 日
にち
• 日
び
• お日
ひ
さま

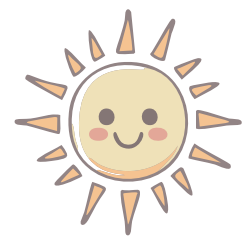

Four empty boxes for practicing the kanji '日' (sun). Each box is divided into four quadrants by a vertical and a horizontal dashed line.

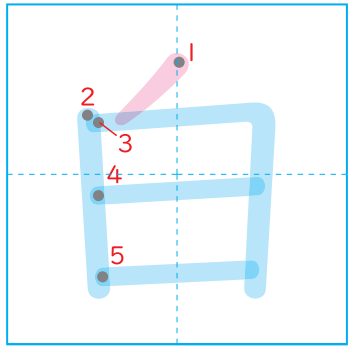

• 白
しろ
• 白
はく
ちよう。
• 一
いち
わの
鳥
とり

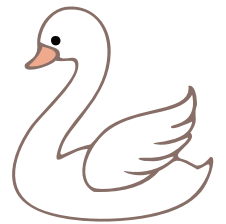

Four empty boxes for practicing the kanji '白' (white). Each box is divided into four quadrants by a vertical and a horizontal dashed line.



かん字のれんしゅう⑧ 「百・早」

なまえ



ゆっくり ていねいに、わくの 中^{なか}に かきましよう。

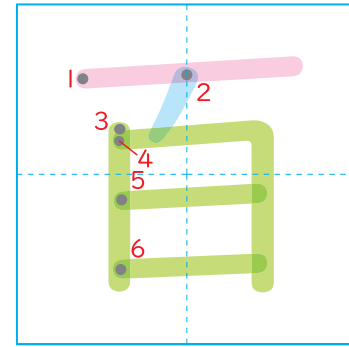

ひやくえん
百円の おかし。



Handwriting practice grid for the character '百' (100). It consists of four rows. Each row has a pink horizontal line at the top, a green square in the middle, and a blue dashed line at the bottom. A small blue diamond shape is placed inside the green square in the first two rows to indicate the starting point for the diagonal stroke.

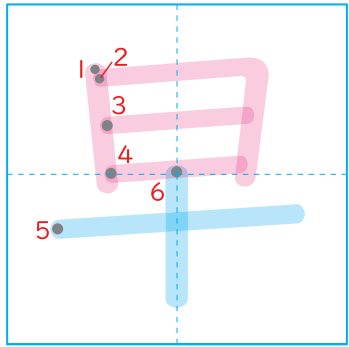

おきるのが 早い。
早^{そう}ちよう

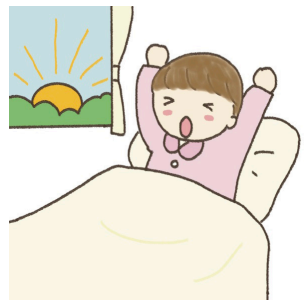

Handwriting practice grid for the character '早' (early). It consists of four rows. Each row has a pink horizontal line at the top and a blue dashed line at the bottom, with a large empty space in between for writing practice.



かん字の れんしゅう⑨ 「目・貝」

なまえ



ゆっくり ていねいに、わくの 中^{なか}に かきましよう。

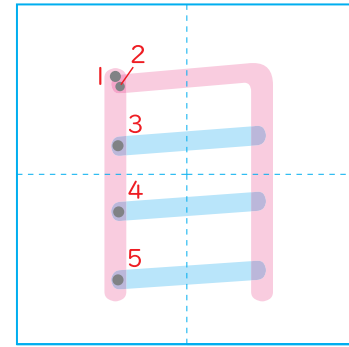

うさぎの 目^め。

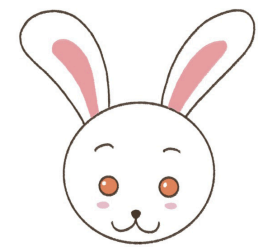

Four vertical writing practice boxes for the kanji '目'. Each box is divided into four horizontal sections by dashed lines. The top section of each box contains a pink outline of the kanji '目' for tracing. The bottom three sections are empty for independent practice.

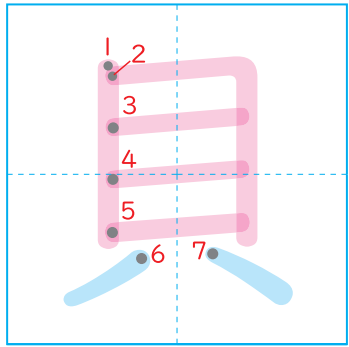

きれいな 貝^{かい}がら。

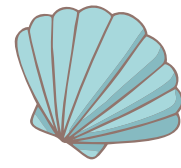

Four vertical writing practice boxes for the kanji '貝'. Each box is divided into four horizontal sections by dashed lines. The top section of each box contains a pink outline of the kanji '貝' for tracing. The bottom three sections are empty for independent practice.



かん字の れんしゅう⑩ 「見・車」

なまえ



ゆっくり ていねいに、わくの 中^{なか}に かきましよう。

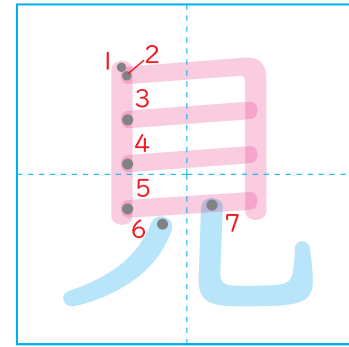

えを 見る^み。

おみせを 見学^{けんがく}する。

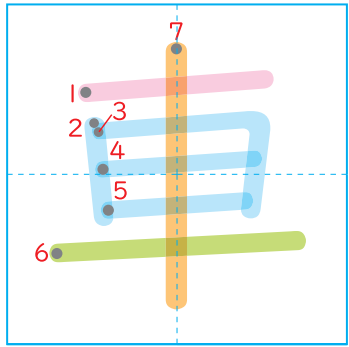
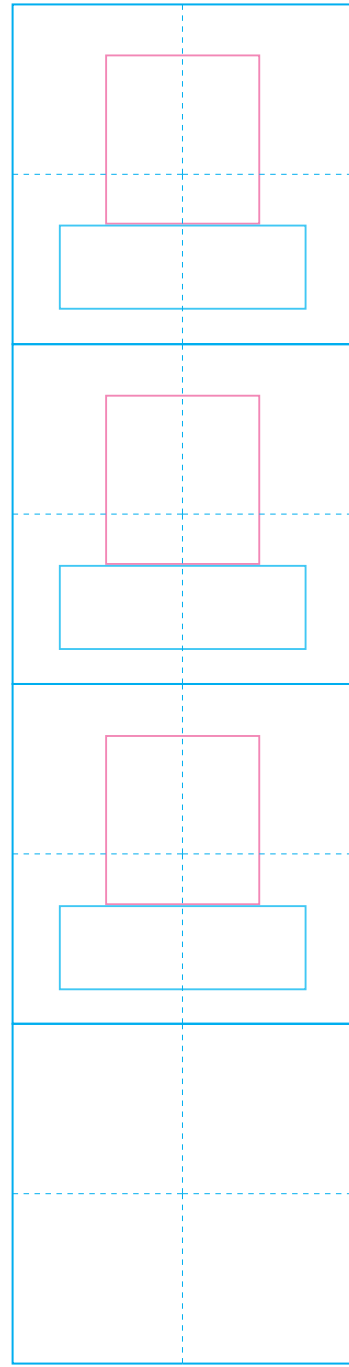
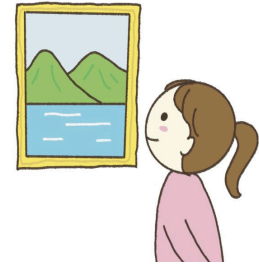

くるま に のる。

あか 赤い じどう車^{しゃ}。

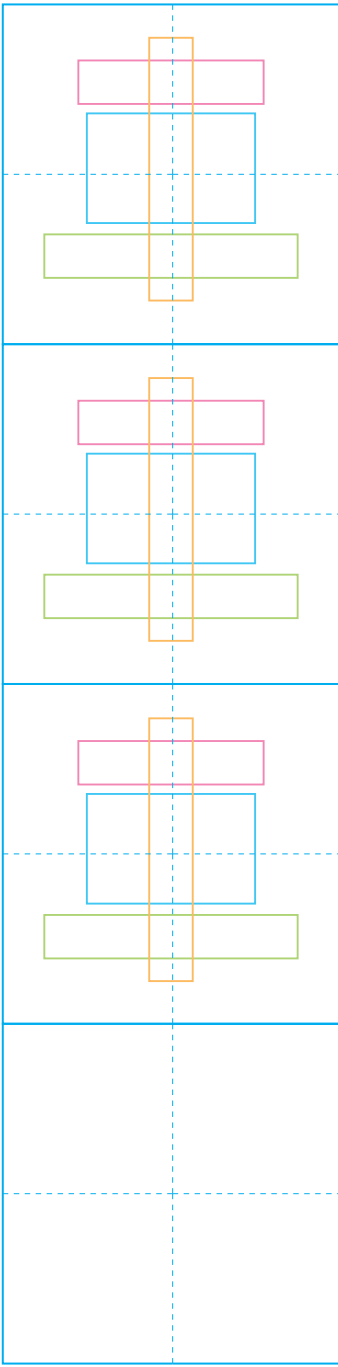

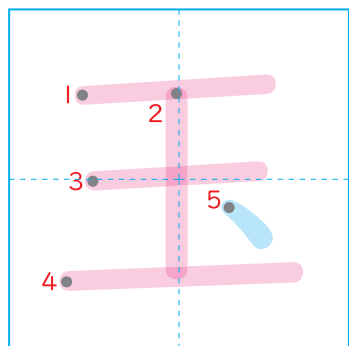

・
大^{おお}
きな

玉^{たま}
。

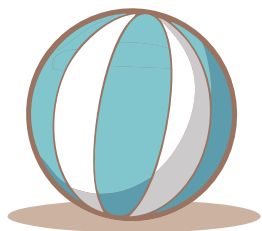

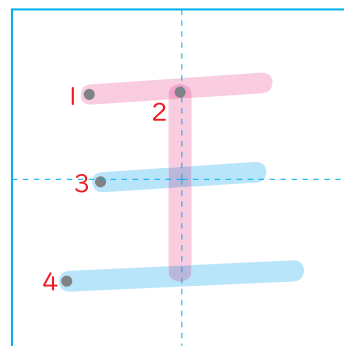

・
王^{おう}
さまの
かんむり。

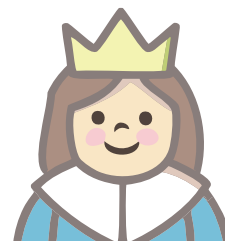

ゆっくり
ていねいに、
わくの
中^{なか}に
かきましょう。



かん字^じの
れんしゅう⑪
【王・玉】

なまえ

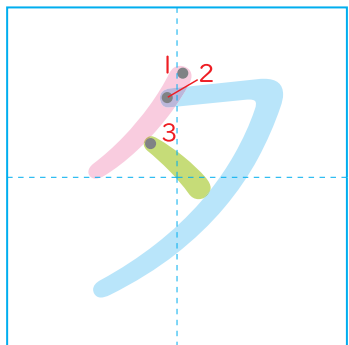
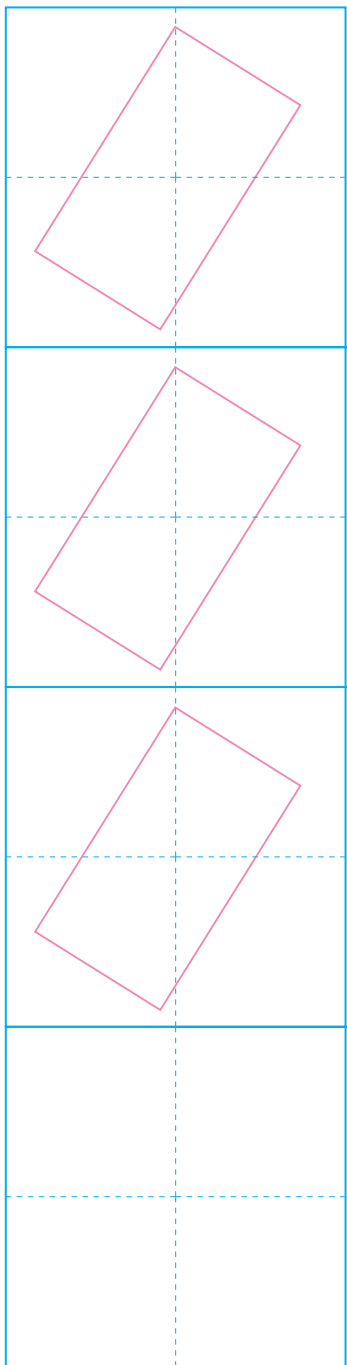

・きれいな
タ^{ゆう}やけ。

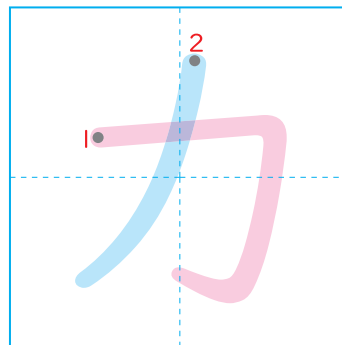
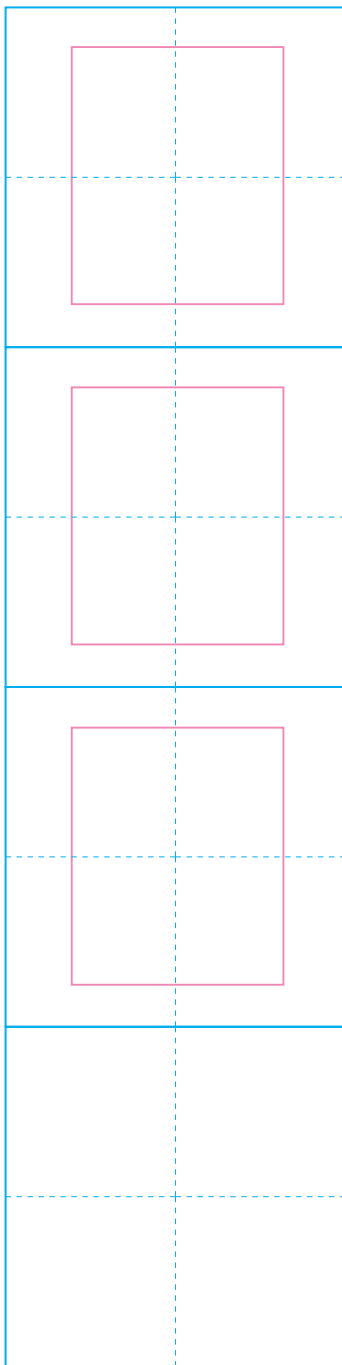

・ちから
カ^だを
出す。



ゆっくり ていねいに、わくの
中^{なか}に かきましよう。



かん字^じの
れんしゅう⑫ 「カ・タ」

なまえ



かん字のれんしゅう⑬ 「名・空」

なまえ

ゆっくり ていねいに、わくの 中^{なか}に かきましよう。

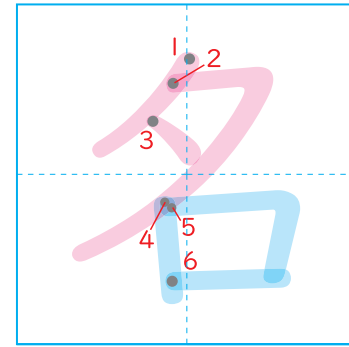

・ 名^なまえを かく。

・ 本^{ほん}の だい名^{めい}。

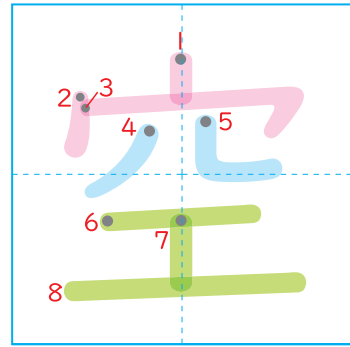
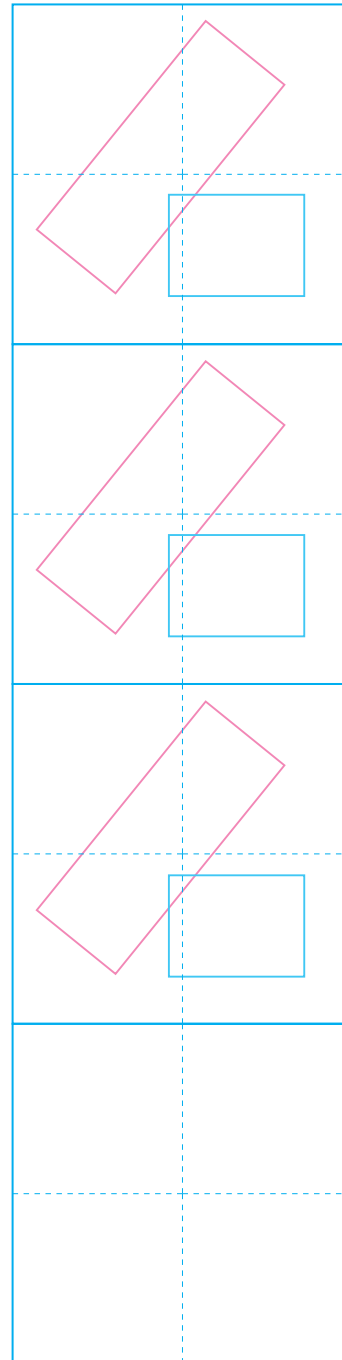
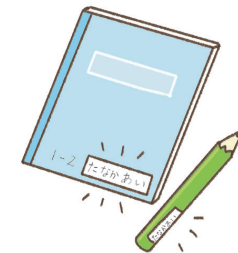

・ 青^{あお}い 空^{そら}。

・ 空^{くう}気を すすう。

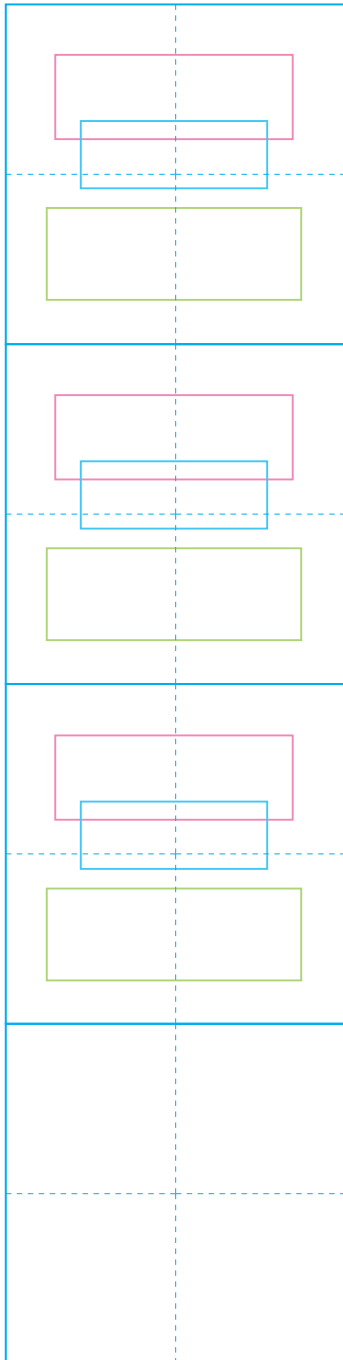
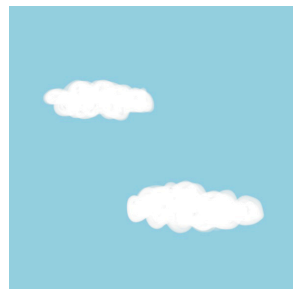



かん字の れんしゅう ⑭ 「二」

なまえ



ゆっくり ていねいに、わくの 中^{なか}に かきましよう。

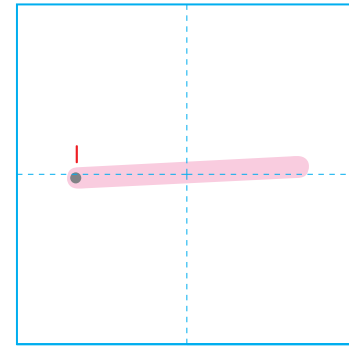

一^{いち}まいの おりがみ。
一^{ひと}つの りんご。



Four vertical writing boxes for practicing the character '一' (ichi). Each box is divided into four horizontal sections by dashed lines. The top section of each box contains a pink rectangular box for writing the character.

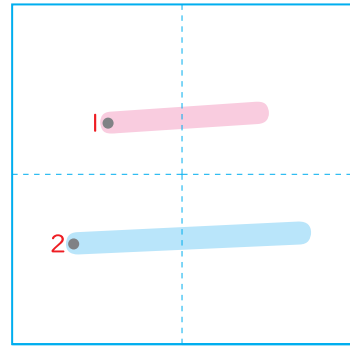

二^{ふた}つの あめ。
二^{にほん}本の えんぴつ。

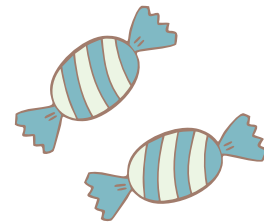

Four vertical writing boxes for practicing the character '二' (ni). Each box is divided into four horizontal sections by dashed lines. The top section of each box contains a pink rectangular box for writing the character.



かん字の れんしゅう ⑮ 【三・四】

なまえ



ゆっくり ていねいに、わくの 中^{なか}に かきましよう。

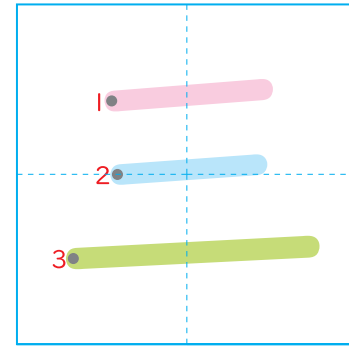

・三^{さん}びきの ねこ。
・三^{みつ}つの たまご。

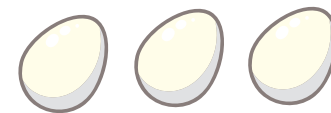

Four sets of handwriting practice boxes, each containing three horizontal lines (pink, blue, green) for writing.

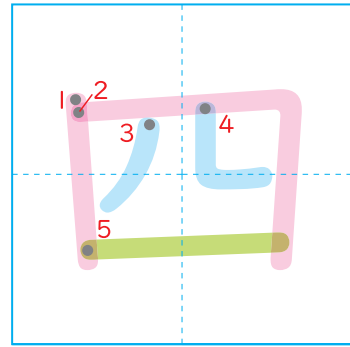

・四^{よん}さつの 本^{ほん}。
・四^{よつ}つの いちご。

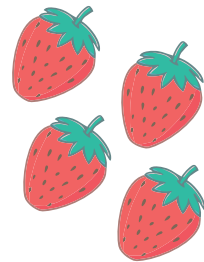

Four sets of handwriting practice boxes, each containing three horizontal lines (pink, blue, green) for writing.



かん字のれんしゅう⑯【五・六】

なまえ



ゆっくり ていねいに、わくの 中なかに かきましよう。

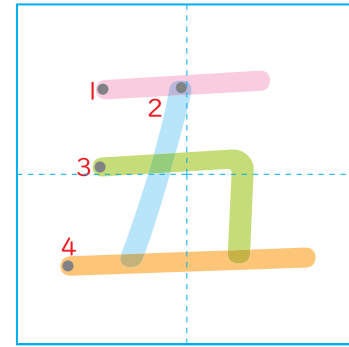

・ 五ごわの とり。
・ 五いつつの あめ。

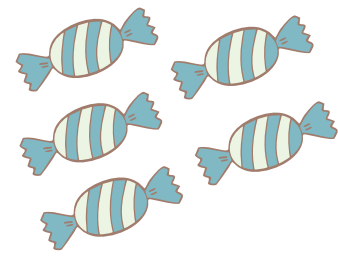

Four empty boxes for writing practice, each divided into four quadrants by a vertical and a horizontal dashed line.

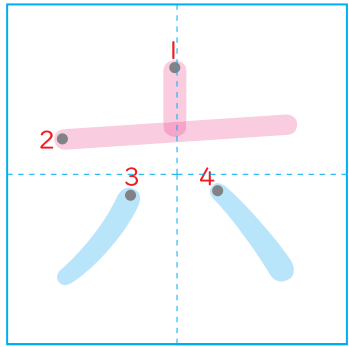

・ 六むっつの たまご。
・ 六ろくにん人の ともだち。

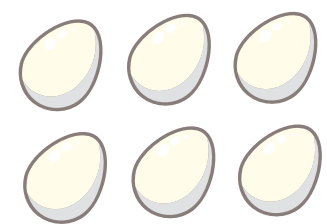

Four empty boxes for writing practice, each divided into four quadrants by a vertical and a horizontal dashed line.

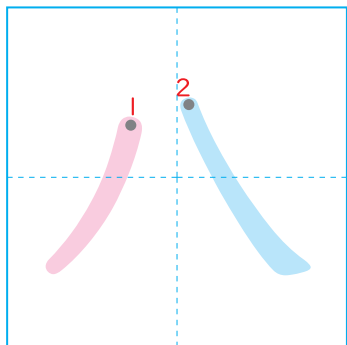
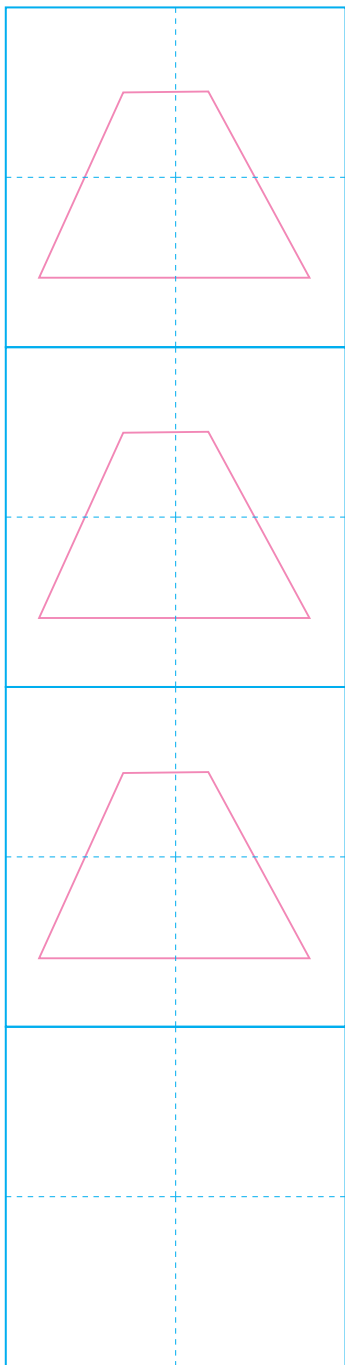

・ はち はち **ハ** だいの **車** くるま。
 ・ やつ やつ **ハ** っの **りんご**。

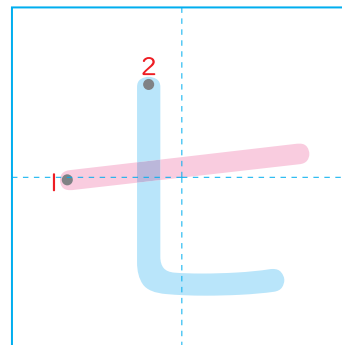
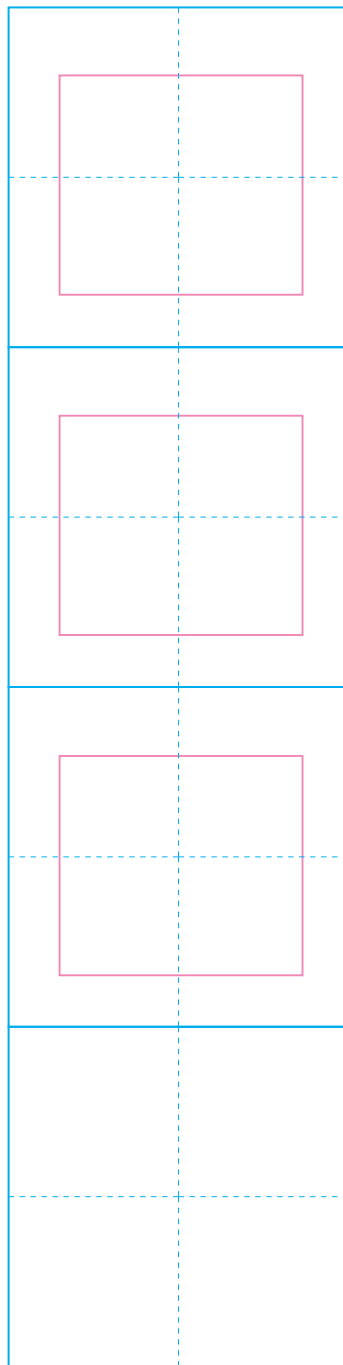
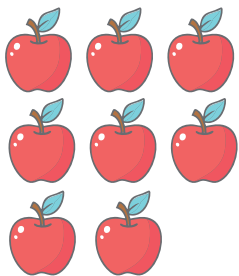

・ しちにん しちにん **七** 人の **先生** せんせい。
 ・ なな なな **七** っの **あめ**。

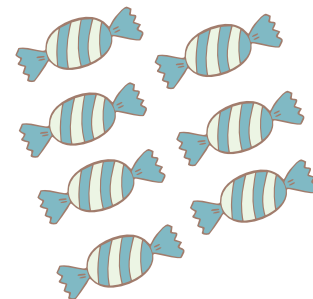

ゆっくり ていねいに、わくの なか 中に かきましよう。



かん字の じ れんしゅう ⑰ 「七・八」

なまえ



かん字の れんしゅう ⑱ 「九・十」

なまえ

ゆっくり ていねいに、わくの 中^{なか}に かきましよう。

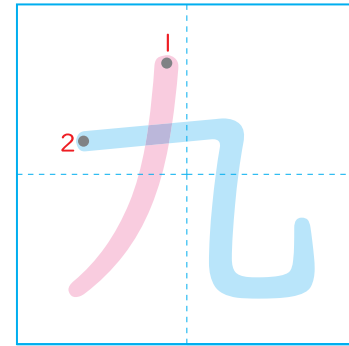

・ ^{この}九つの あめ。

・ ^{きゆう}九ひきの ねこ。

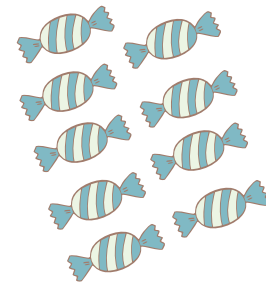

Four empty square boxes for writing practice, each with a dashed horizontal line across the middle.

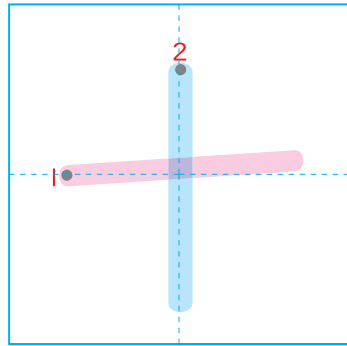

・ ^{とおか}十日かん つづける。

・ ^{じゆうえんだま}十円玉



Three vertical rectangular boxes for writing practice, each with a dashed horizontal line across the middle.



かん字の れんしゅう ⑱ 「上・下」

なまえ



ゆっくり ていねいに、わくの 中^{なか}に かきましよう。

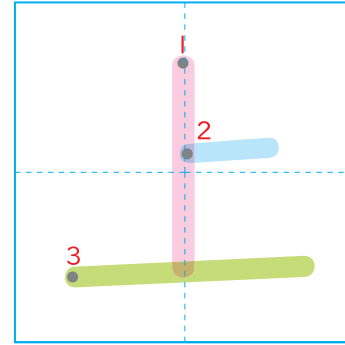

つくえの 上^{うえ}。

かおを 上^あげる。

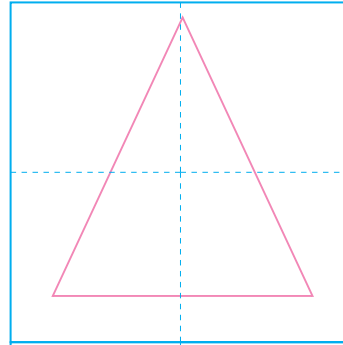
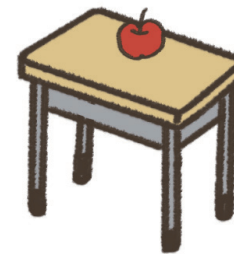

つくえの 下^{した}。

手を 下^さげる。

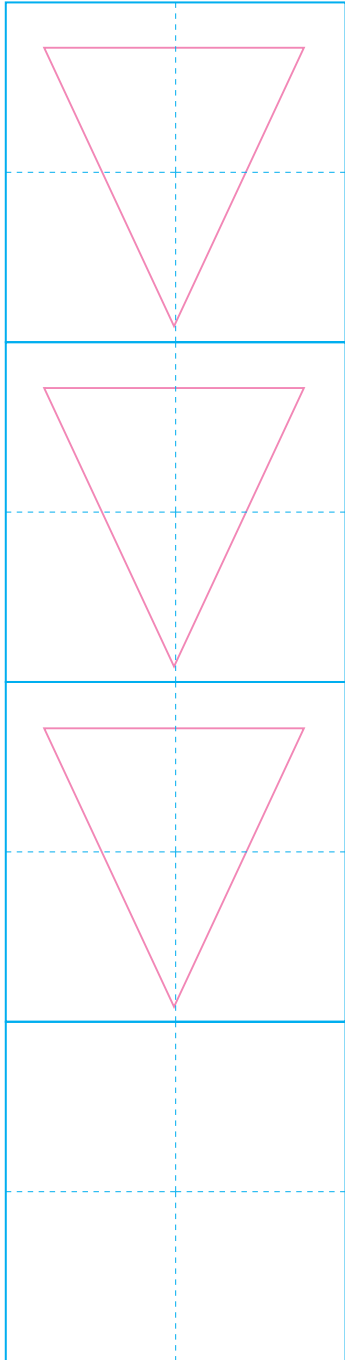
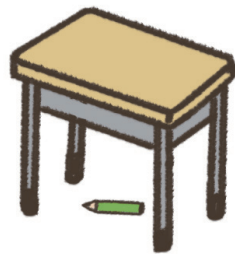

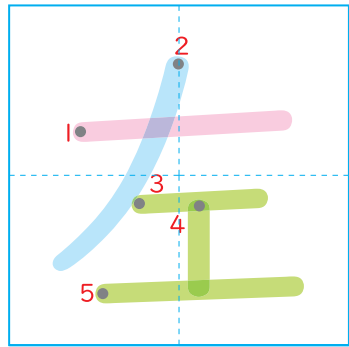

・ ひだり
左を

見る。



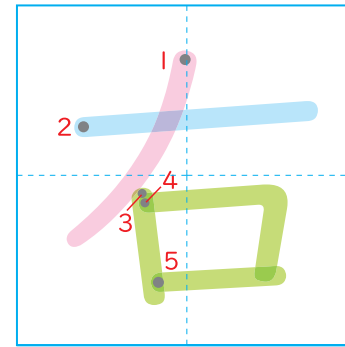

・ みぎ
右を

見る。



ゆっくり ていねいに、わくの 中^{なか}に かきましよう。



かん字^じの れんしゅう② 「右・左」

なまえ



かん字のれんしゅう⑳ 「小・手」

なまえ



ゆっくり ていねいに、わくの 中^{なか}に かきましよう。

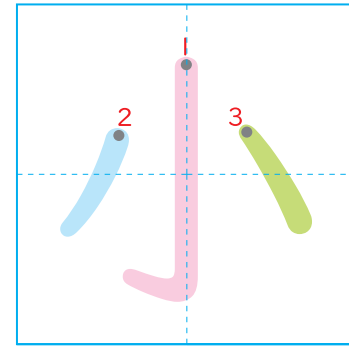

・ 小^{ちい}さい 犬^{いぬ}。

・ 小^{しょうがっこう}学校^{がっこう}に かよう。

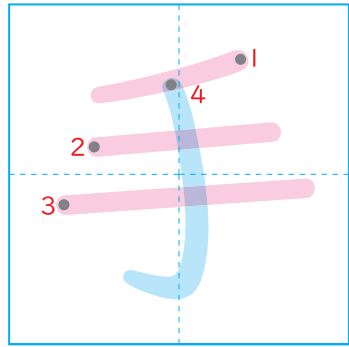
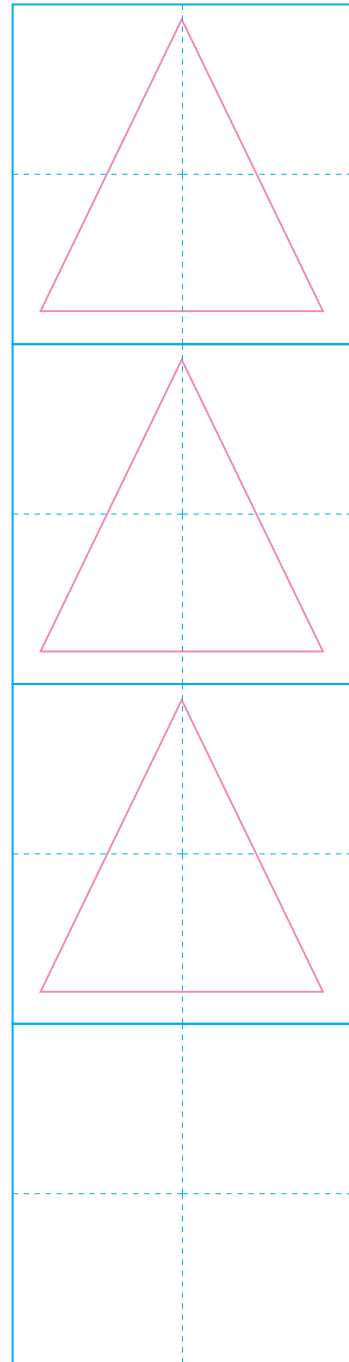

・ 手^てを ぶんる。

・ あく手^{しゅ}を する。

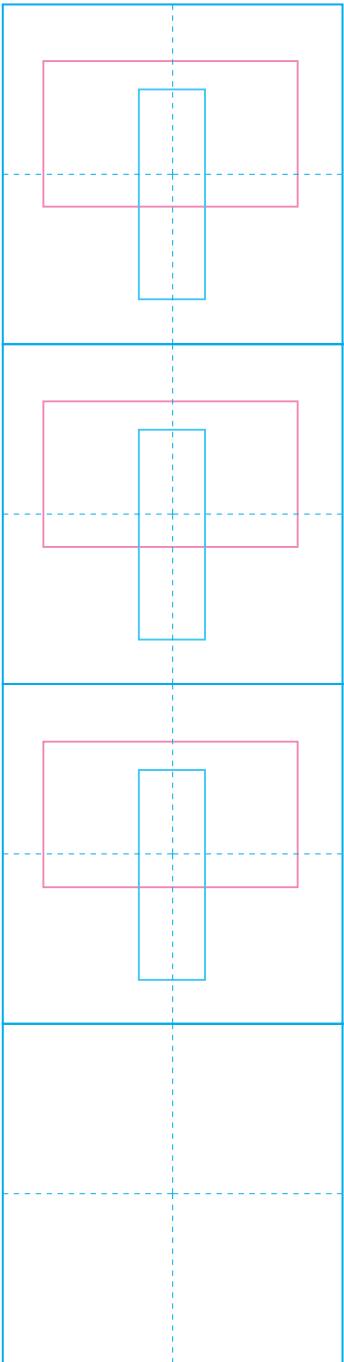

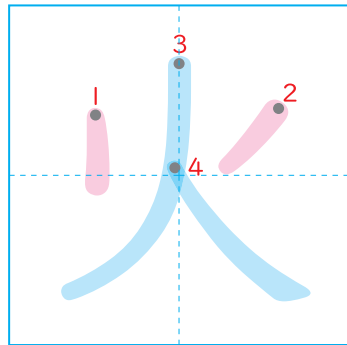

・火^かよう日^び
 ・火^ひをけす。

9月						
日	月	火	水	木	金	土
					1	2
3	4	5	6	7	8	9
10	11	12	13	14	15	16
17	18	19	20	21	22	23
24	25	26	27	28	29	30

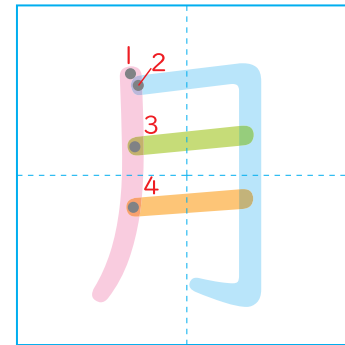

・月^{げつ}よう日^び
 ・きれいな月^{つき}。

9月						
日	月	火	水	木	金	土
					1	2
3	4	5	6	7	8	9
10	11	12	13	14	15	16
17	18	19	20	21	22	23
24	25	26	27	28	29	30



ゆっくり ていねいに、わくの
 中^{なか}に かきましよう。



かん字^じの
 れんしゅう② 「月・火」

なまえ

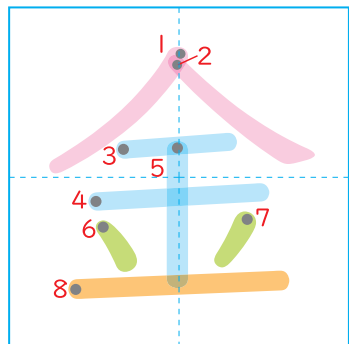

・ **金**^{きん}よう**日**^び
 ・ **お金**^{かね}を **はらう**。

9月						
日	月	火	水	木	金	土
					1	2
3	4	5	6	7	8	9
10	11	12	13	14	15	16
17	18	19	20	21	22	23
24	25	26	27	28	29	30

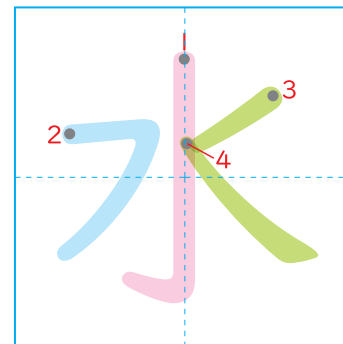

・ **水**^{すい}よう**日**^び
 ・ **水**^{みず}を **のむ**。

9月						
日	月	火	水	木	金	土
					1	2
3	4	5	6	7	8	9
10	11	12	13	14	15	16
17	18	19	20	21	22	23
24	25	26	27	28	29	30



ゆっくり ていねいに、わくの **中**^{なか}に かきましよう。



かん字^じの れんしゅう^{じゅう}⑳ 「水・金」

なまえ



かん字の れんしゅう ②④ 「土・立」

なまえ



ゆっくり ていねいに、わくの 中^{なか}に かきましよう。

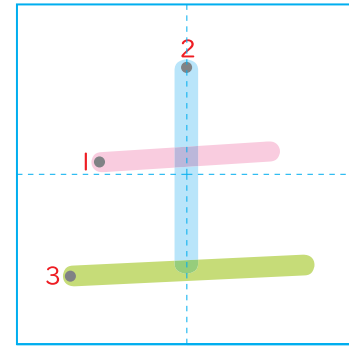

・ 土^どよう日^び
・ 土^{つち}を ほる。

9月						
日	月	火	水	木	金	土
					1	2
3	4	5	6	7	8	9
10	11	12	13	14	15	16
17	18	19	20	21	22	23
24	25	26	27	28	29	30

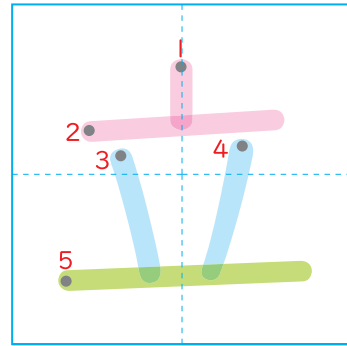
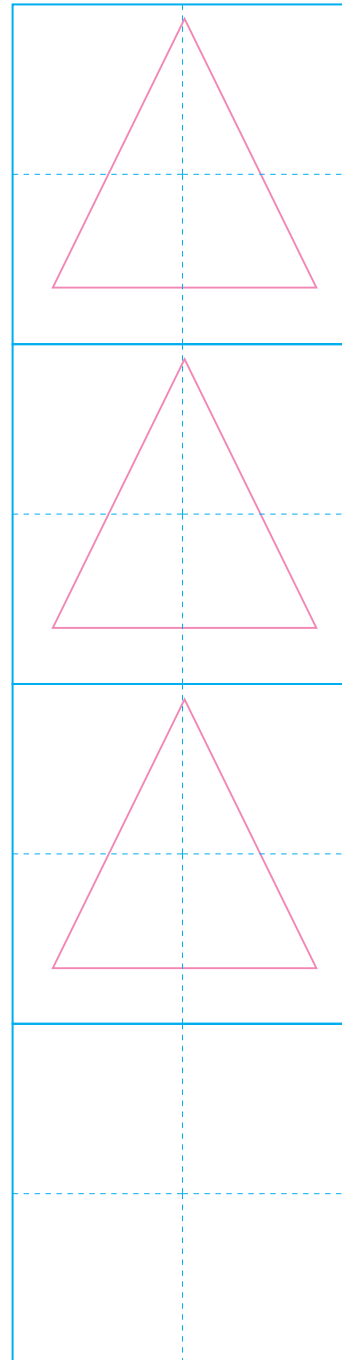

・ まっすぐに 立^たつ。

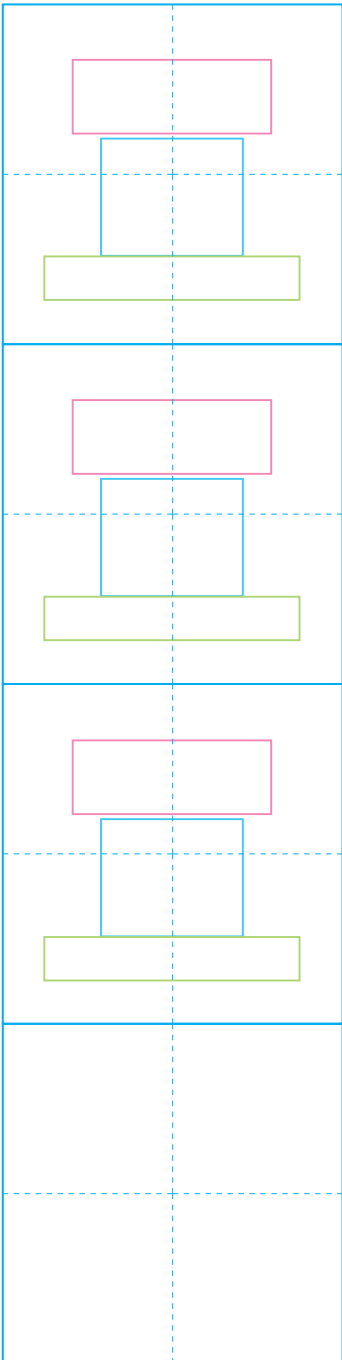

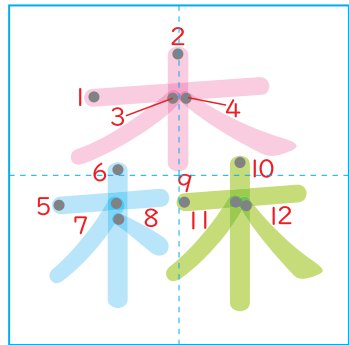

森もりの
 森しんりんを
 中なかに
 まもる。

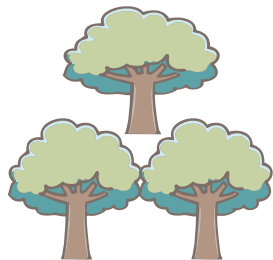

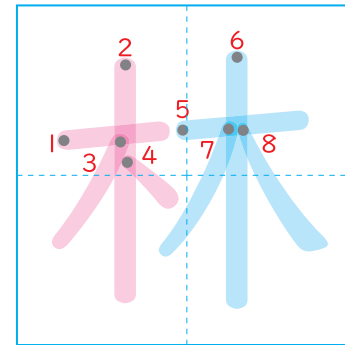

林はやしの
 みどりの
 中なかに
 森しんりん。

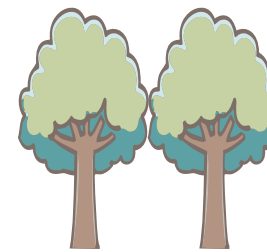

ゆっくり
 ていねいに、
 わくの
 中なかに
 かきましよう。



かん字じの
 れんしゅう25 「林・森」

なまえ



かん字の れんしゅう ②⑥ 「校・休」

なまえ



ゆっくり ていねいに、わくの 中^{なか}に かきましよう。

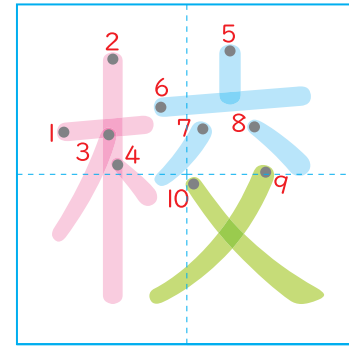

・ 学^{がっこう}校へ いく。

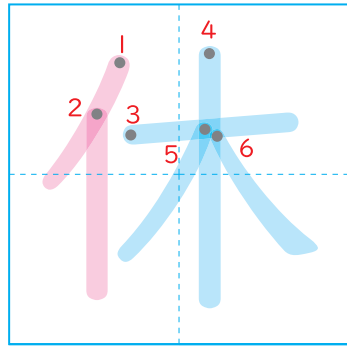
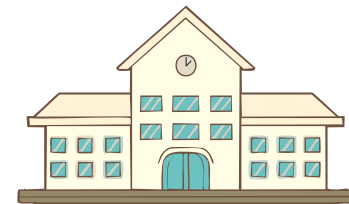

・ 少^{すこ}し 休^{やす}む。
・ 休^{きゅうじつ}日の よてい。



Handwriting practice grid with four rows of boxes for writing.

Handwriting practice grid with four rows of boxes for writing.

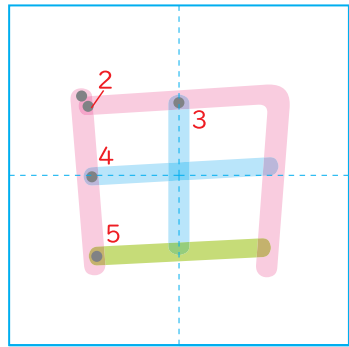

・みどりの
田^たんぼ。

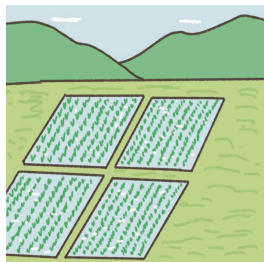

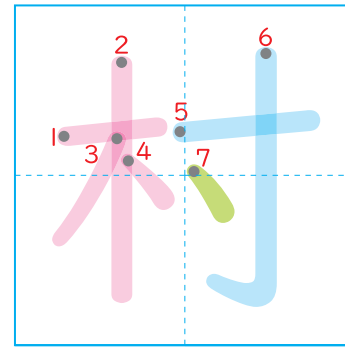

・しずかな
村^{むら}。



ゆっくり
ていねいに、
わくの
中^{なか}に
かきましよう。



かん字^じの
れんしゅう^⑳「村・田」

なまえ

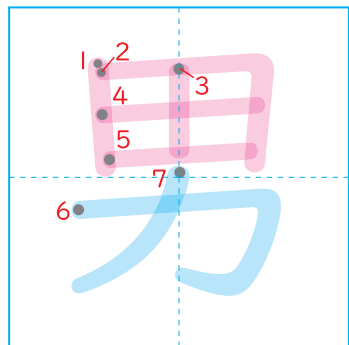

男子 だんし と

男の子 おとこ

あそび。



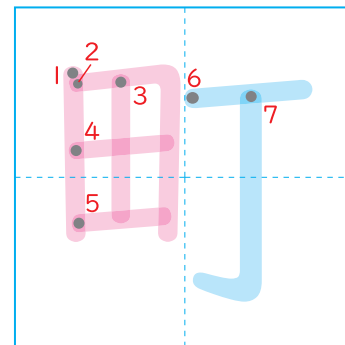

大きな町。



ゆっくりていねいに、わくの
 中なかにかきましよう。



かん字じの
 れんしゅう⑳ 「町・男」

なまえ



かん字のれんしゅう⑳ 「女・糸」

なまえ



ゆっくりていねいに、わくの
中に
かきましょう。

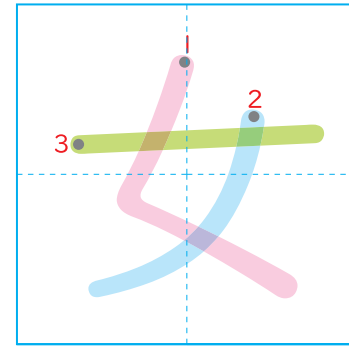

・おんな
女の子

・じよし
女子とあそぶ。

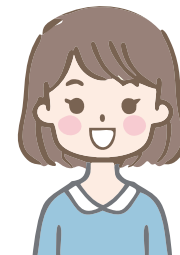

Four empty boxes for writing practice, each divided into four quadrants by a vertical and a horizontal dashed line.

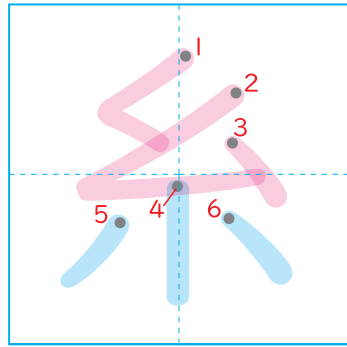

・しろ
白
・いと
糸。

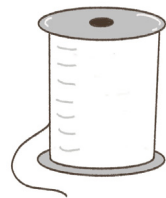

Four empty boxes for writing practice, each divided into four quadrants by a vertical and a horizontal dashed line.

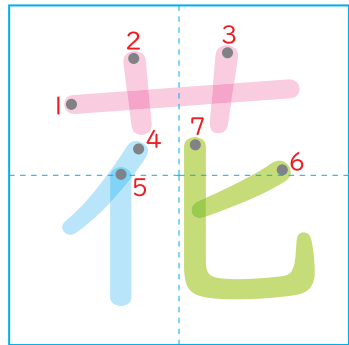

・ 学校がっこうの
 ・ 花はなが
 さく。
 花かだん。

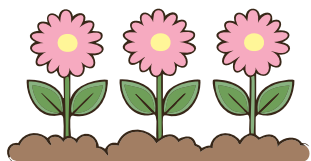

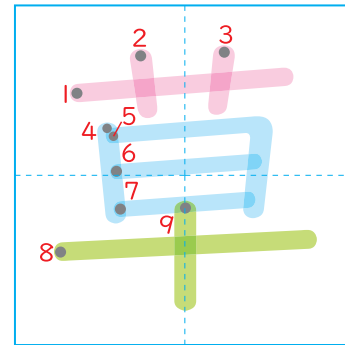

・ 草くさが
 生はえる。



ゆっくり
 ていねいに、
 わくの
 中なかに
 かきましよう。



かん字じの
 れんしゅう③⑩
 「草・花」

なまえ



かん字のれんしゅう③①「赤・青」

なまえ



ゆっくりていねいに、わくの
中に
かきましよう。

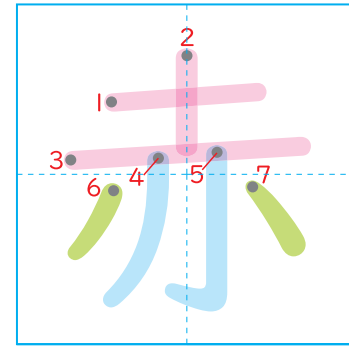

赤い
花。



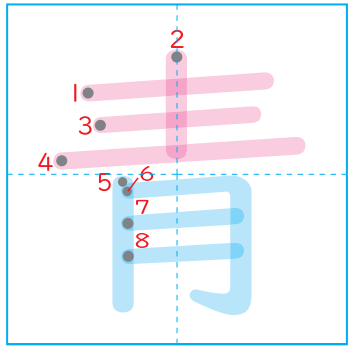
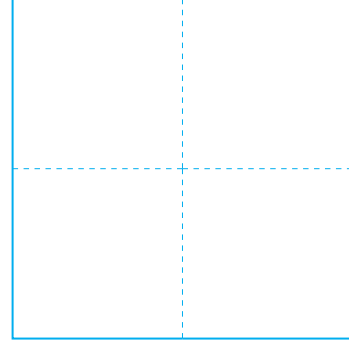
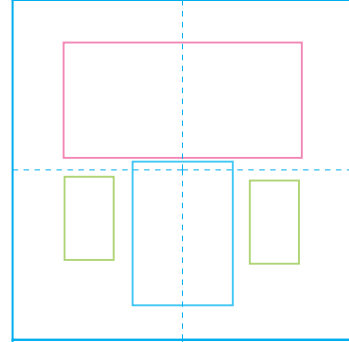
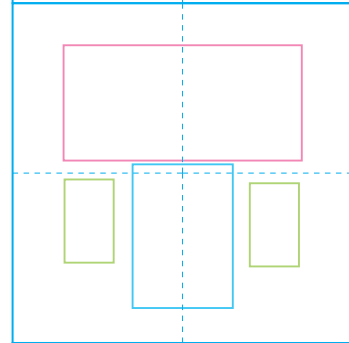
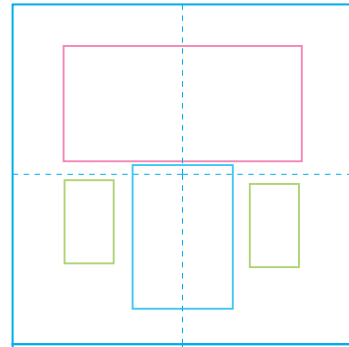
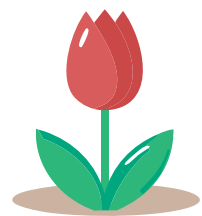



赤ちゃん
が
なく。

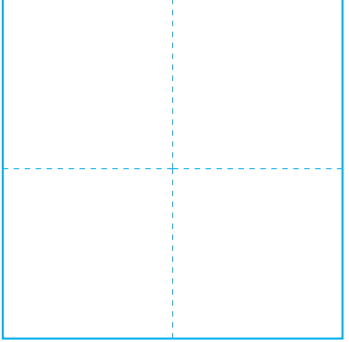
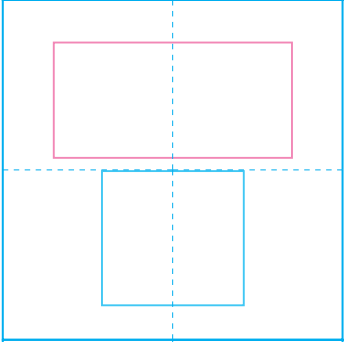
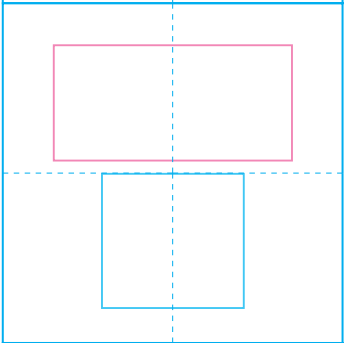
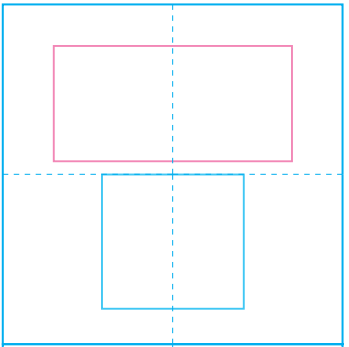

青い
ふく。

きれいな
青空。



	
	
	

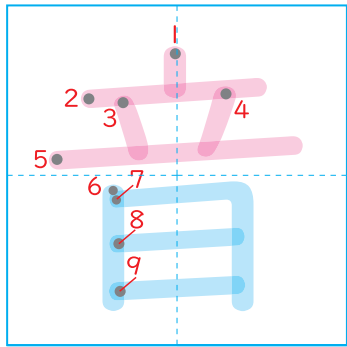

・
大^{おお}
きな

音^{おと}。



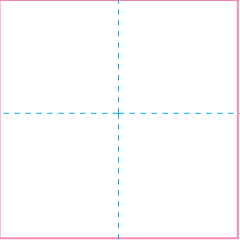
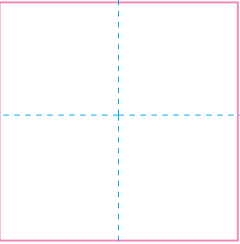
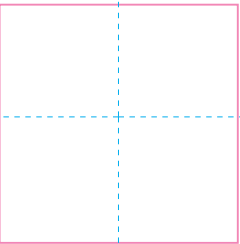

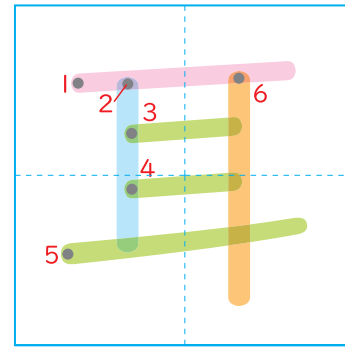
・
うさぎの

耳^{みみ}。

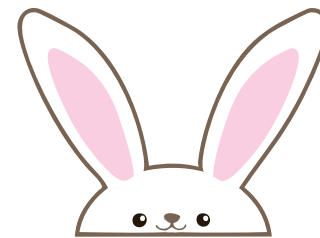

ゆっくり
ていねいに、
わくの
中^{なか}に
かきましょう。



かん字^じの
れんしゅう^③ 「耳・音」

なまえ

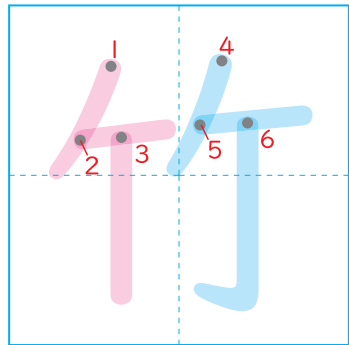

・
竹^{たけ}
の

林^{はやし}
。

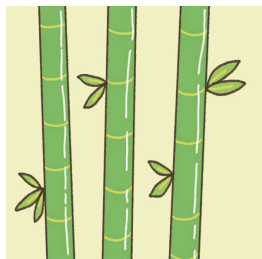

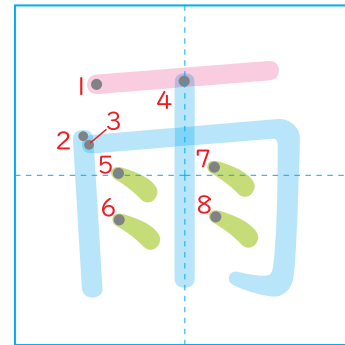

・
雨^{あめ}
が

ふる。



ゆっくり ていねいに、わくの
中^{なか}に かきましよう。



かん字^じの
れんしゅう³³ 「雨・竹」

なまえ



かん字のれんしゅう③④ 「文・千」

なまえ



ゆっくり ていねいに、わくの 中^{なか}に かきましよう。

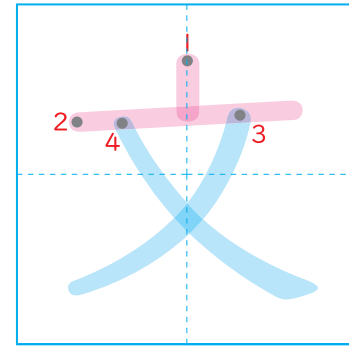

・文^{ぶん}を よむ。

・文字^{もじ}を かく。



Four vertical writing practice boxes, each with a dashed midline and a solid top line. The top portion of each box is highlighted in pink.

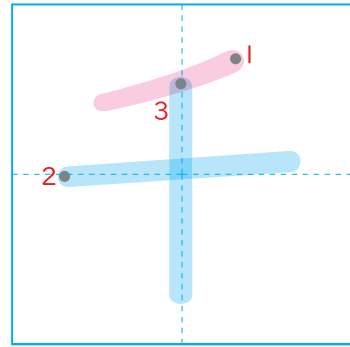

・千^{せん}円^{えん}を つ

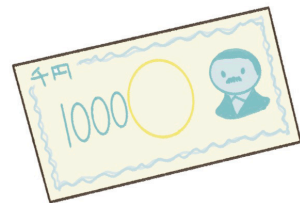

Four vertical writing practice boxes, each with a dashed midline and a solid top line. The top portion of each box is highlighted in pink.

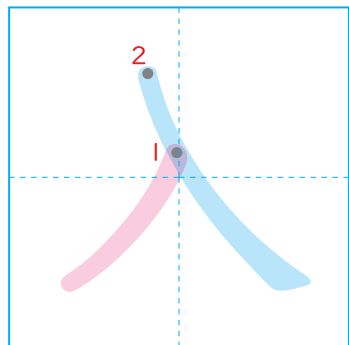
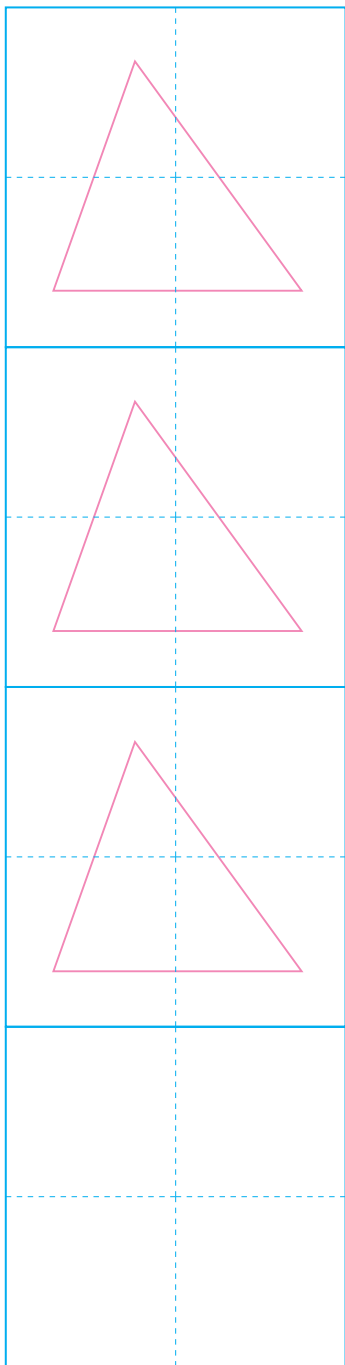

・ へやに
 入る。
 ・ 入学^{にゅうがく}しき

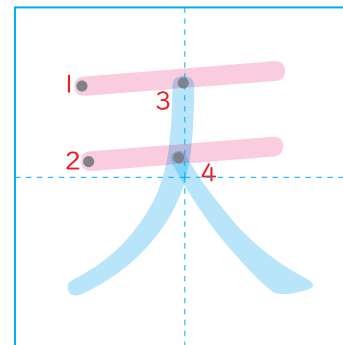
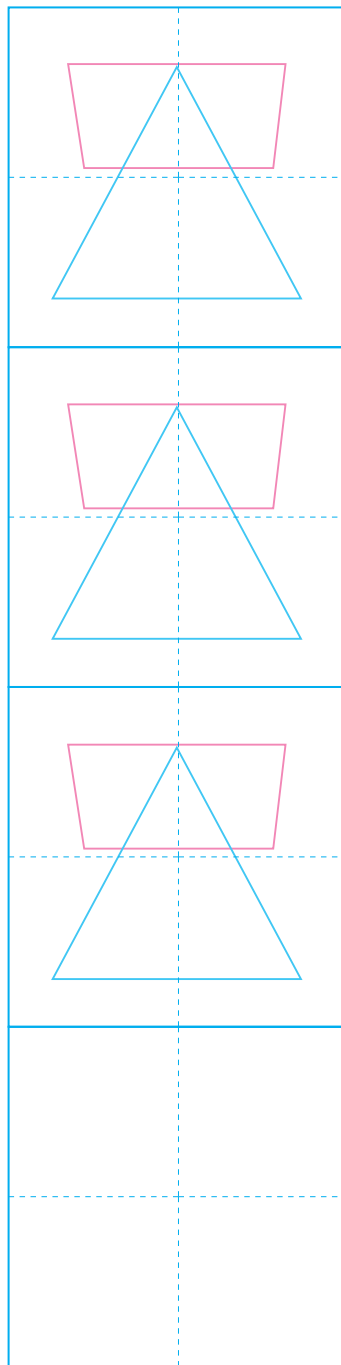

・ 天気^{てんき}が
 いい。

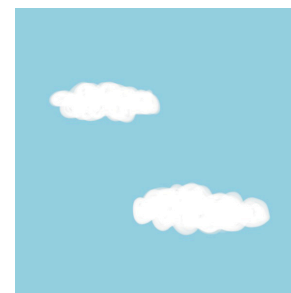

ゆっくり ていねいに、わくの
 中^{なか}に かきましよう。



かん字^じの
 れんしゅう³⁵ 「天・入」

なまえ



かん字のれんしゅう③⑥【出・正】

なまえ



ゆっくりていねいに、わくのなか中に かきましよう。

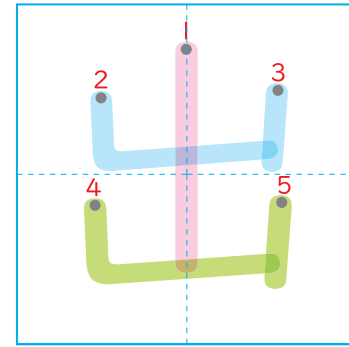

・ 出でる。
・ こえを 出だす。

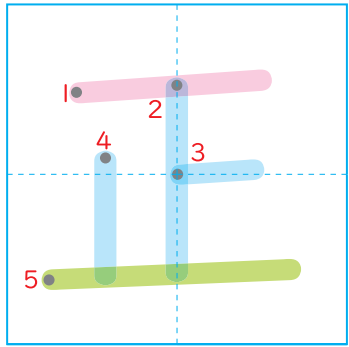
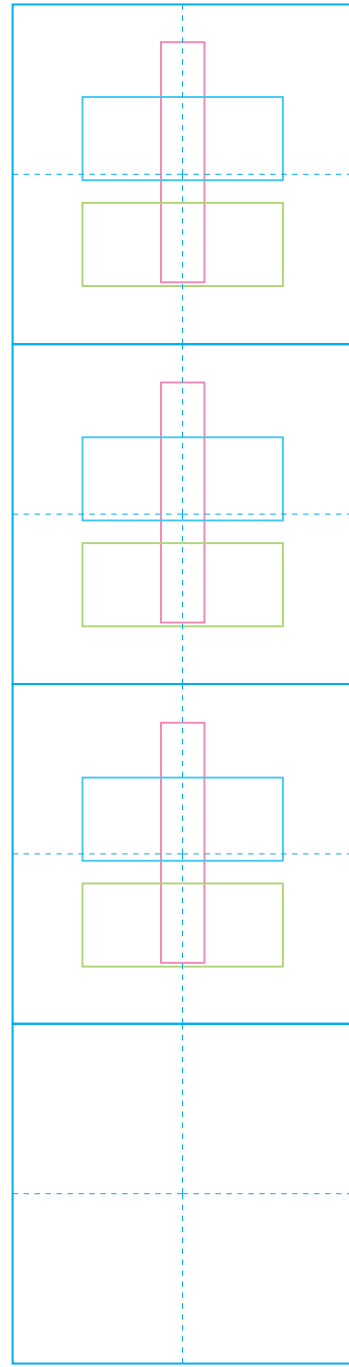
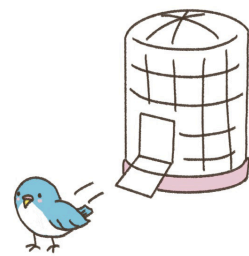

・ 正ただしい ことたええ。
・ お正しょうがつ月の あそびび。

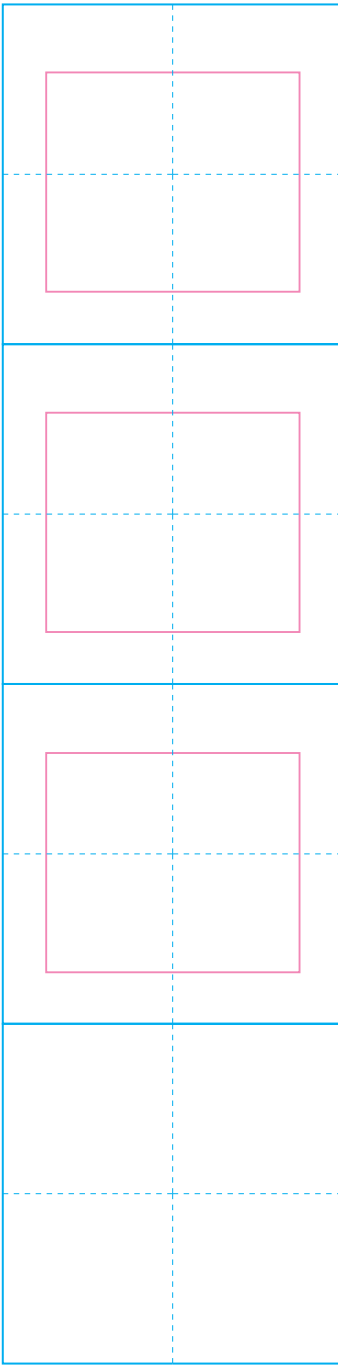
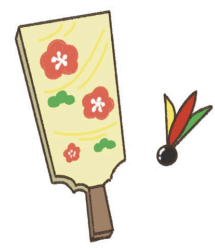



かん字の れんしゅう ③⑦ 「先・生」

なまえ



ゆっくり ていねいに、わくの 中^{なか}に かきましよう。

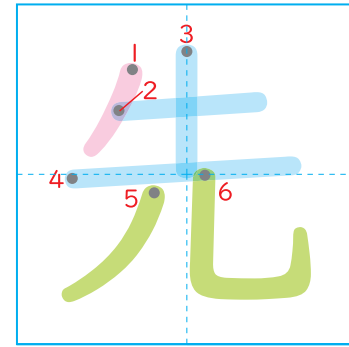

- 先生^{せんせい}が はなす。
- 先^{さき}に 出^でかける。



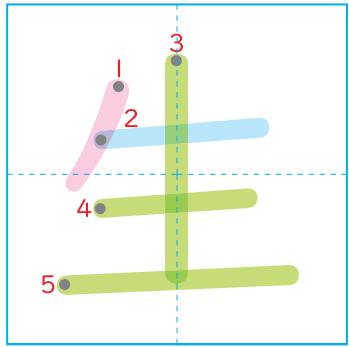

- 犬^{いぬ}が 生ま^うれる。
- ながく 生^いきる。
- 先生^{せんせい}



かん字の れんしゅう ③⑧ 「年・円」

なまえ

ゆっくり ていねいに、わくの 中^{なか}に かきましよう。

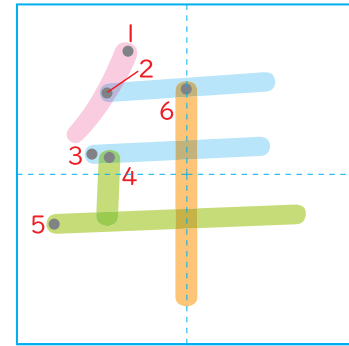

・ 年^{とし}をとる。

・ 一^{いちねんせい}年生^{せい}になる。



Four empty boxes for writing practice, each with a vertical dashed line and a horizontal dashed line.

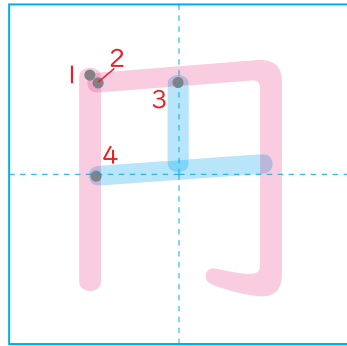

・ ひやくえん
百^{ひやく}円^{えん}
はらう。



Four empty boxes for writing practice, each with a vertical dashed line and a horizontal dashed line.



かん字のれんしゅう③⑨ 「子・字」

なまえ



ゆっくりていねいに、わくの
中なかにかきましよう。

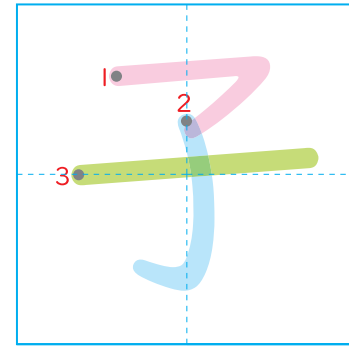

・子こどもが はしる。

・女子じよしと 男子だんし。



Four empty writing boxes for practicing the kanji '子'. Each box is divided into four quadrants by a vertical and a horizontal dashed line.

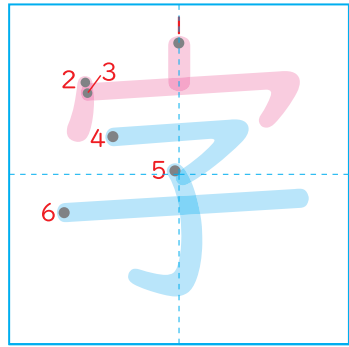

・かん字じを かく。



Four empty writing boxes for practicing the kanji '字'. Each box is divided into four quadrants by a vertical and a horizontal dashed line.



かん字のれんしゅう④〇【学・気】

なまえ



ゆっくりていねいに、わくの
中に
かきましよう。

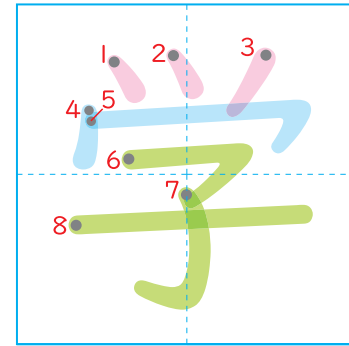

かん字を
学ぶ。
学校に
いく。

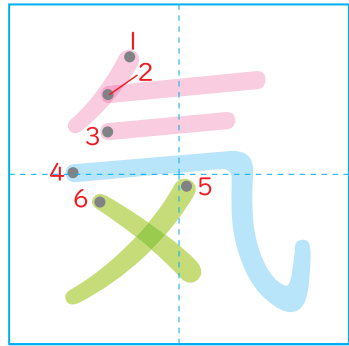
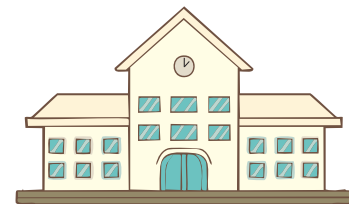

げん
気が
ある。



Four sets of handwriting practice boxes with dashed lines for alignment.

Four sets of handwriting practice boxes with dashed lines for alignment.