

・
点^{てん}
と

丸^{まる}
。

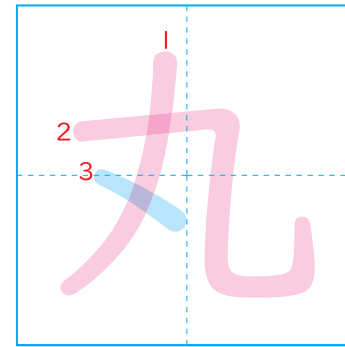
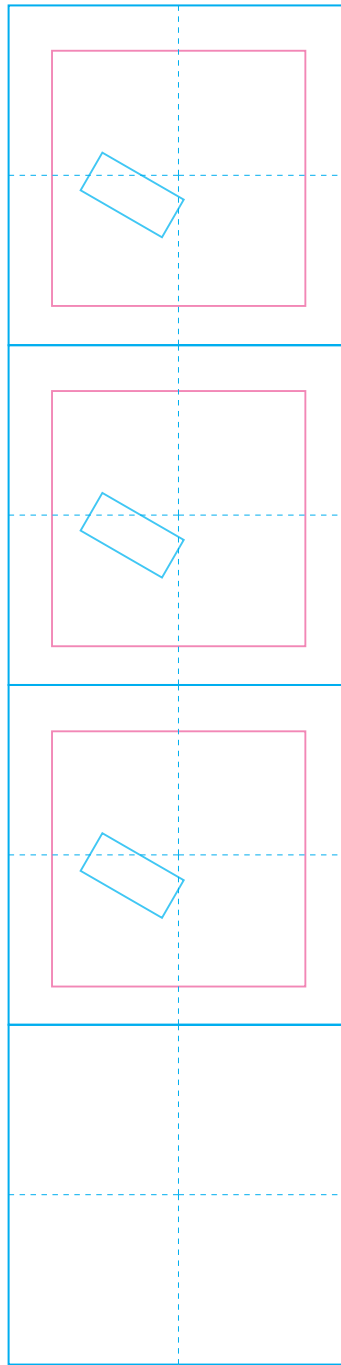
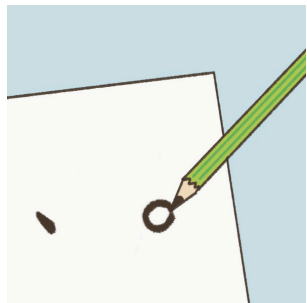

・
丸^{まる}
を

つける。

・
丸^{まる}
い

玉^{たま}
。

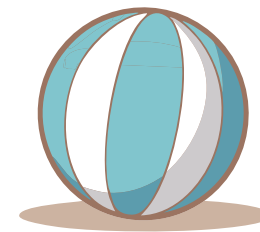

ゆっくり ていねいに、わくの
中^{なか}に 書^かきましょう。



かん字^じの れんしゅう① 「丸・点」

なまえ

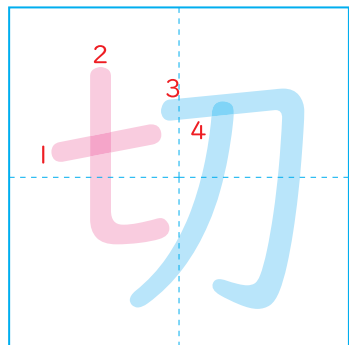

・紙^{かみ}を切^きる。
 ・大^{たい}切^{せつ}なたか^たら^らもの。

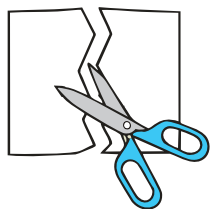

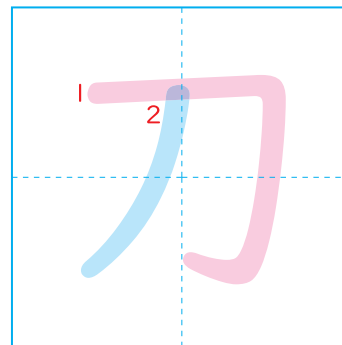

・むか^かしの^な刀^な。

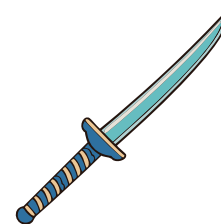

ゆっくり ていねいに、わくの
 中^{なか}に 書^かきましょう。



かん字^じの れんしゅう② 「刀・切」

なまえ



かん字の れんしゅう③ 「分・才」

なまえ



ゆっくり ていねいに、わくの 中に 書きましょう。

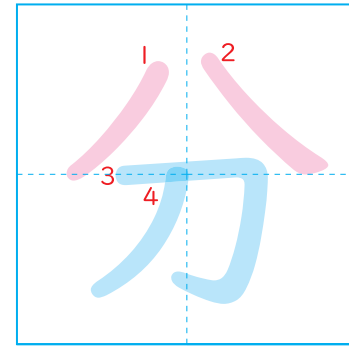

・ 半分 はんぶん に 分ける わ。

・ 五分 ごぶん まつ。

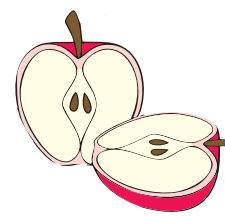

Four vertical boxes for writing practice, each containing a dashed outline of the character '分'.

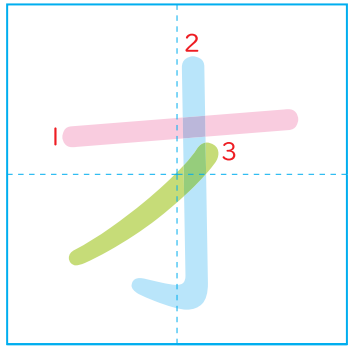

・ 七才 ななさい に なる。



Four vertical boxes for writing practice, each containing a dashed outline of the character '才'.



かん字のれんしゅう④「方・方」

なまえ



ゆっくりていねいに、わくの
中に書きましょう。

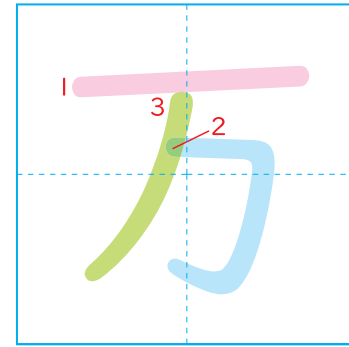

いちまんえん
一万円さつ



Four empty boxes for practicing writing the kanji '万' (10,000).

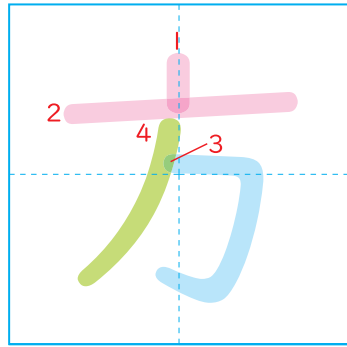

みぎ
右の方を見る。
ゆうがた
夕方になる。



Four empty boxes for practicing writing the kanji '方' (direction).



かん字の れんしゅう⑤ 「元・今」

なまえ

ゆっくり ていねいに、わくの 中に 書きましょう。

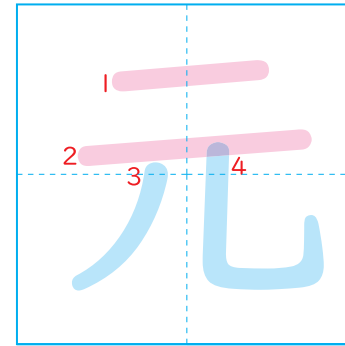

元 げんき
に なる。



Four vertical writing practice boxes, each divided into a top pink box and a bottom blue box by a dashed line.

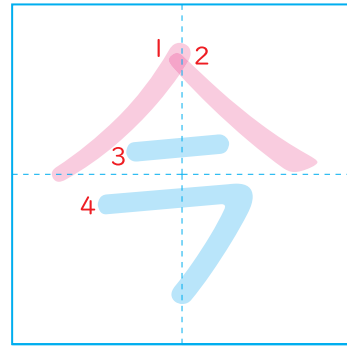

今と 今月
いま こんげつ
むかし。 の よてい。

9月						
日	月	火	水	木	金	土
					1	2
3	4	5	6	7	8	9
10	11	12	13	14	15	16
17	18	19	20	21	22	23
24	25	26	27	28	29	30

Four vertical writing practice boxes, each divided into a top pink box and a bottom blue box by a dashed line.

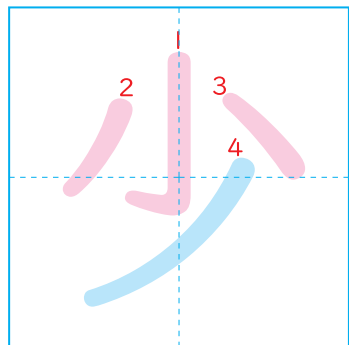
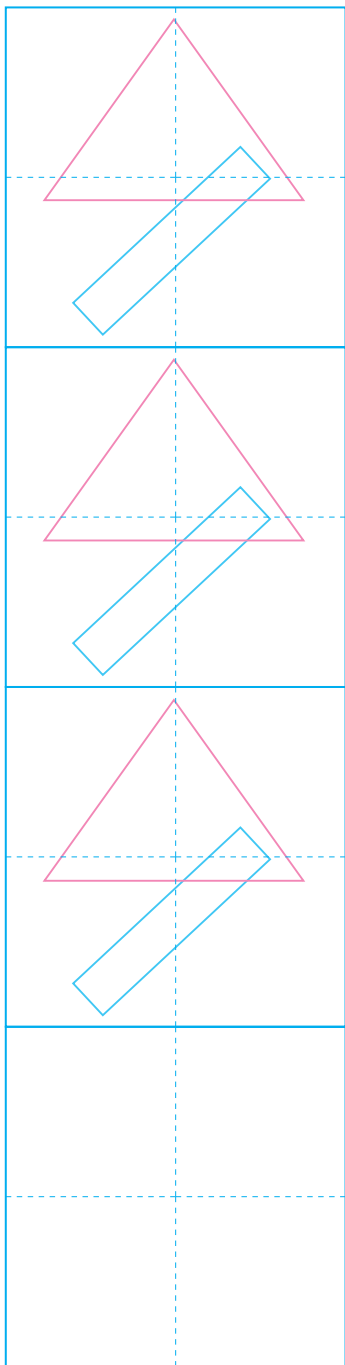

・ にもつが
 少ない。

・ 少し
 小さい。

・ 少年

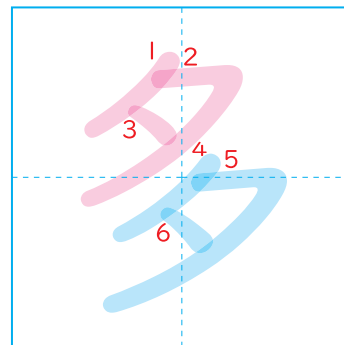
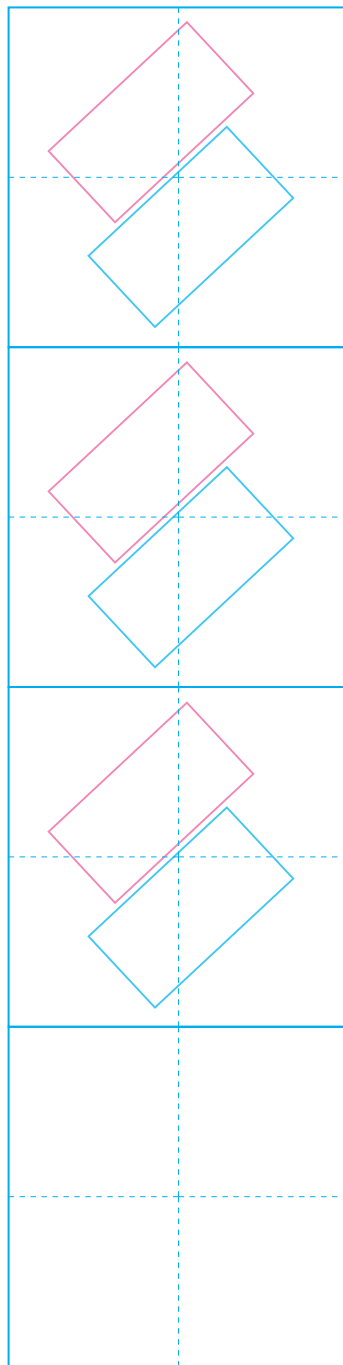

・ にもつが
 多い。



ゆっくり ていねいに、わくの
 中に 書きましょう。



かん字の
 れんしゅう⑥「多・少」

なまえ

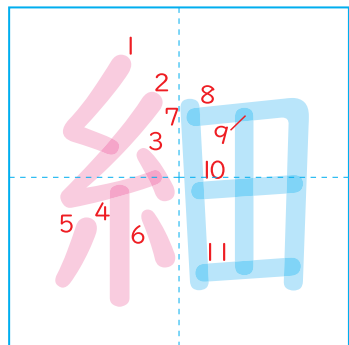

・
細^{ほそ}
い

木^き
。



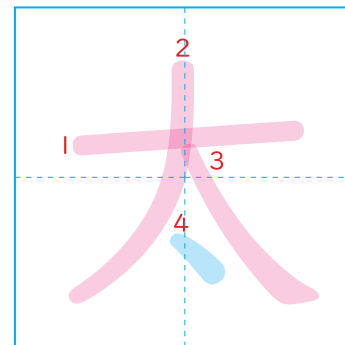

・
丸^{まる}太^た
を
切^き
る。

・
太^{ふと}
い
木^き
。

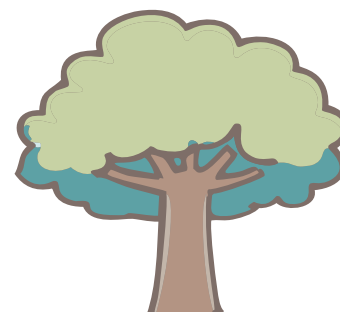

ゆっくり ていねいに、わくの
中^{なか}に
書^かきましよう。



かん字^じの
れんしゅう⑦
「太・細」

なまえ

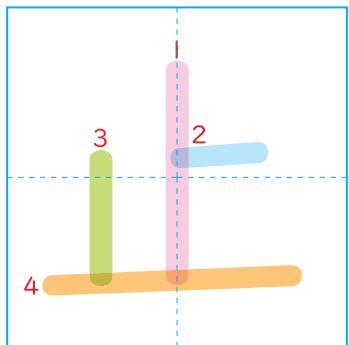

・ 車くるまが 止とまる。
 ・ 立たち入いりきん 止し

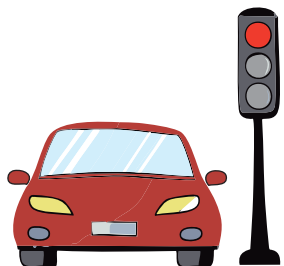

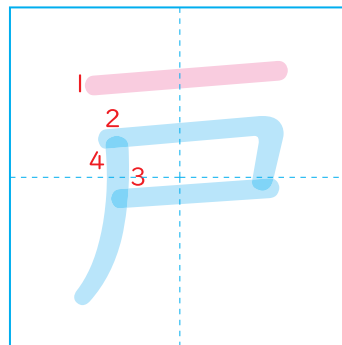

・ 戸とを あける。



ゆっくり ていねいに、わくの 中なかに 書かきましよう。



かん字じの れんしゅう⑧ 「戸・止」

なまえ



かん字の れんしゅう⑨ 「内・外」

なまえ



ゆっくり ていねいに、わくの 中に 書きましょう。

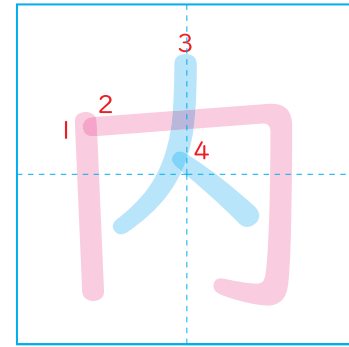

・はこの 内がわ。
・町内のおまつり。

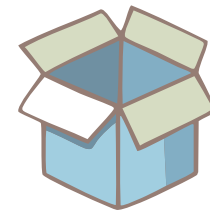

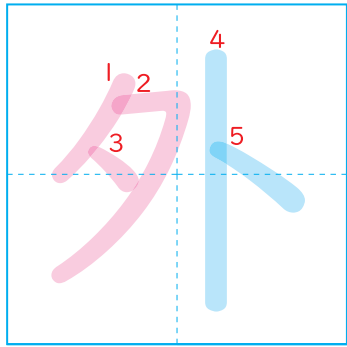

・外に出る。
・外出をする。

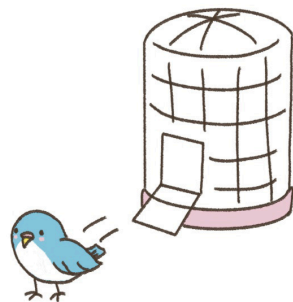

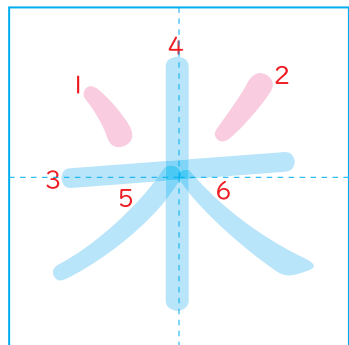

・ お米^{こめ}を

買^かう。



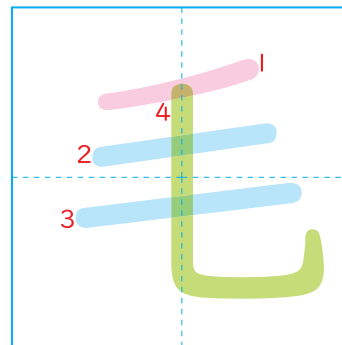

・ 毛^けが

長^{なが}い。



ゆっくり ていねいに、わくの 中^{なか}に 書^かきましょう。



かん字^じの れんしゅう⑩ 「毛・米」

なまえ

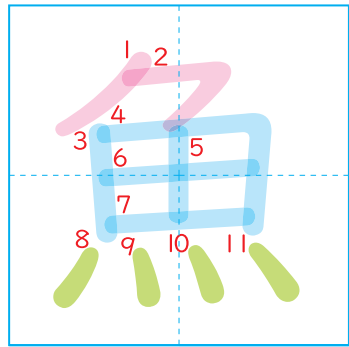

・ おお
大きな

・ さかな
魚。

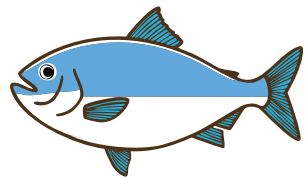

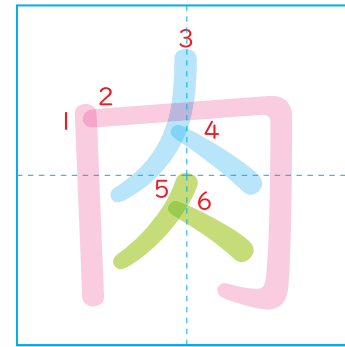

・ にく
肉を
買う。

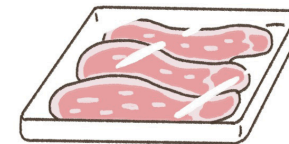

ゆっくり ていねいに、わくの
中に 書きましょう。



かん字の れんしゅう ⑪ 「肉・魚」

なまえ



かん字のれんしゅう⑫「友・広」

なまえ



ゆっくりていねいに、わくの
中に書きましょう。

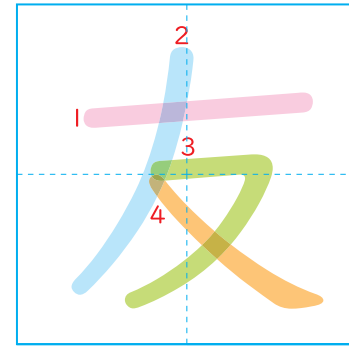

友だちになる。

友人に会う。



Four empty writing boxes for practicing the kanji '友'.

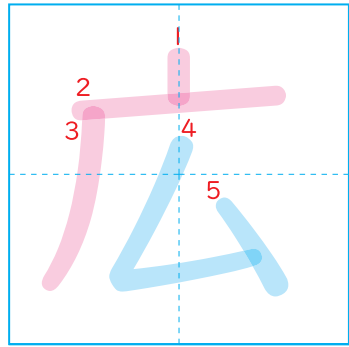

広いにわ。



Four empty writing boxes for practicing the kanji '広'.



かん字の れんしゅう ⑬ 「台・半」

なまえ



ゆっくり ていねいに、わくの 中に 書きましょう。

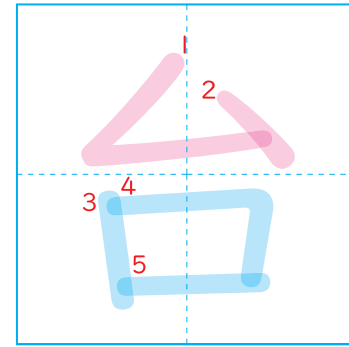

・ 台に のる。
・ 台風が くる。



Four sets of handwriting practice boxes, each consisting of a top pink box and a bottom blue box, separated by a dashed midline.

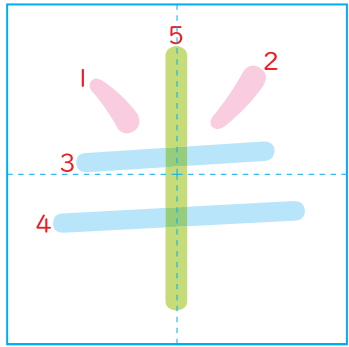

・ 半分に 分ける。

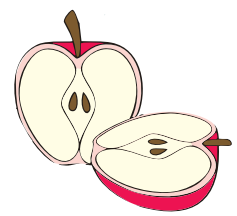

Four sets of handwriting practice boxes, each consisting of a top pink box and a bottom blue box, separated by a dashed midline.



かん字の れんしゅう ⑭ 「父・母」

なまえ

ゆっくり ていねいに、わくの 中に 書きましょう。

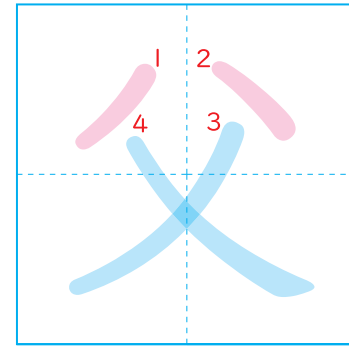

父の 名前。
お父さん

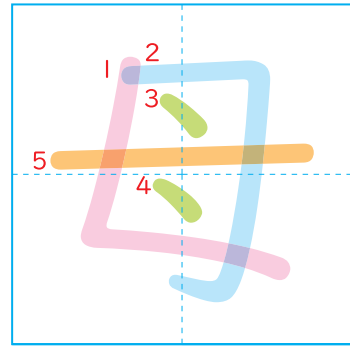
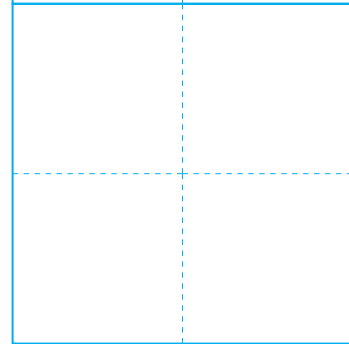
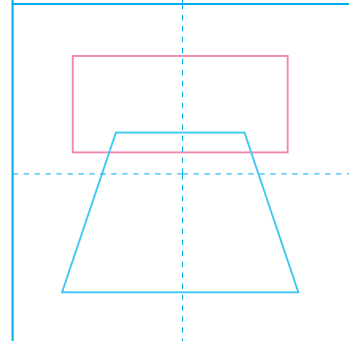
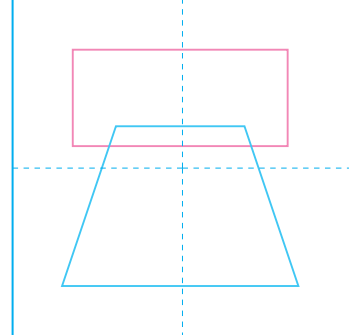
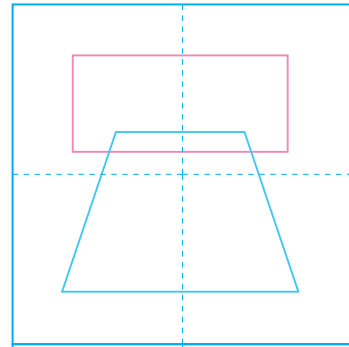
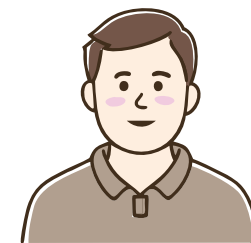

母の 名前。
お母さん

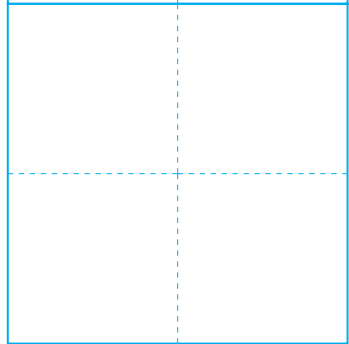
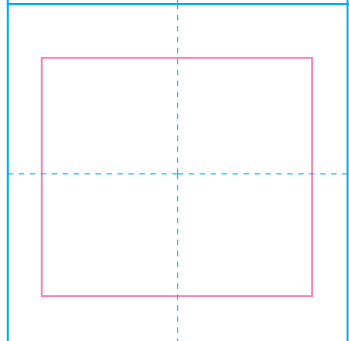
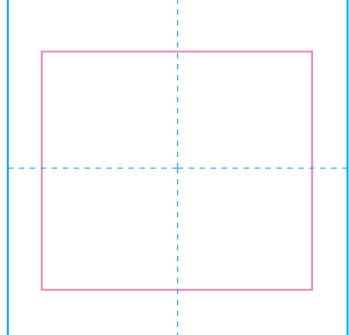
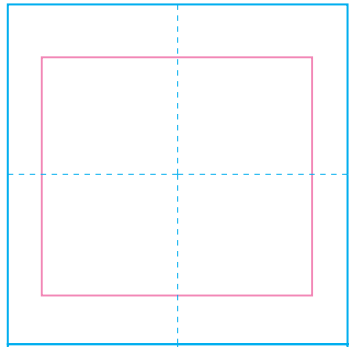
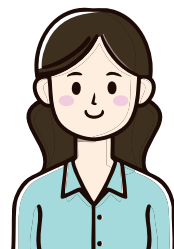

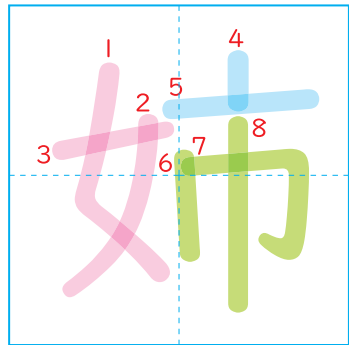

・ **姉**^{あね} の くつ。
 ・ **お姉**^{ねえ} さん

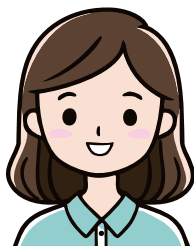

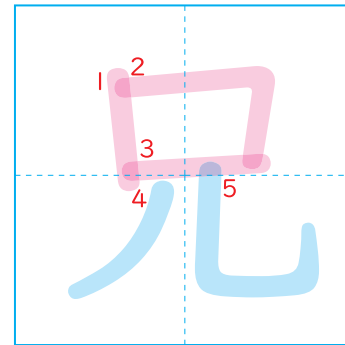

・ **兄**^{あに} の ふく。
 ・ **お兄**^{にい} さん
 ・ **兄弟**^{きょうだい}

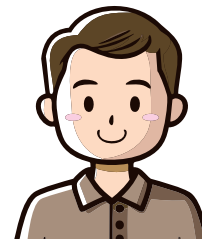

ゆっくり ていねいに、わくの **中**^{なか} に **書**^か きましよう。



かん字^じの れんしゅう ⑮ 「兄・姉」

なまえ

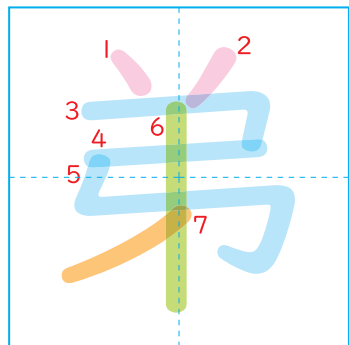

・ おとうと
 弟の
 ・ きょうだい
 兄弟の本。



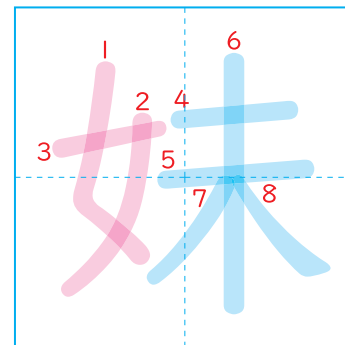

・ いもうと
 妹の
 おもちや。



ゆっくり
 ていねいに、
 わくの
 中に
 書きましよう。



かんじの
 れんしゅう⑯
 「妹・弟」

なまえ



かん字のれんしゅう⑰【牛・馬】

なまえ



ゆっくりていねいに、わくの
中に書きましょう。

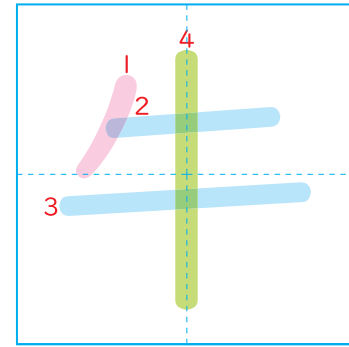

牛が
いる。
牛にゆうを
のむ。

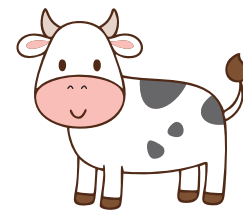

Four empty boxes for practicing writing the kanji '牛' (cow).

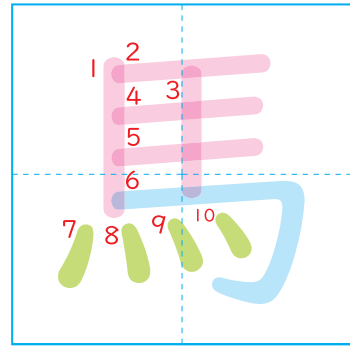

馬が
走る。
馬車に
のる。

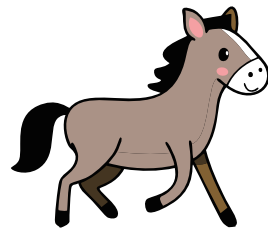

Four empty boxes for practicing writing the kanji '馬' (horse).

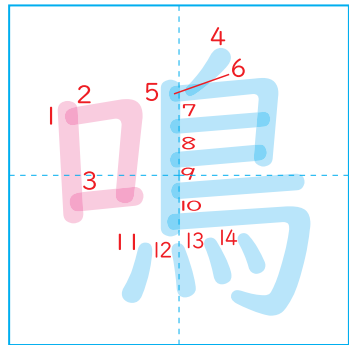

・ 鳥^{とり}が

鳴^なく。



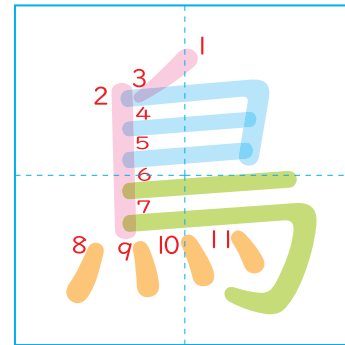

・ きれいな

白鳥^{はくちよう}。

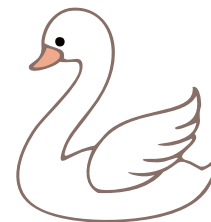

・ 鳥^{とり}が

とび。



ゆっくり ていねいに、わくの 中^{なか}に 書^かきましょう。



かん字^じの れんしゅう ⑱ 「鳥・鳴」

なまえ



かん字のれんしゅう⑱ 「弓・矢」

なまえ



ゆっくり ていねいに、わくの 中に 書きましょう。

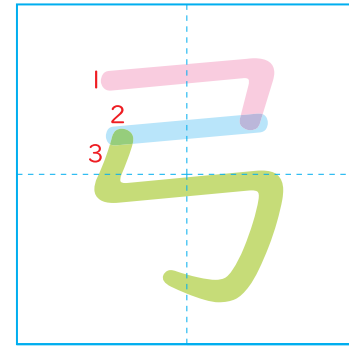

・ 弓^{ゆみ}を 引^ひく。

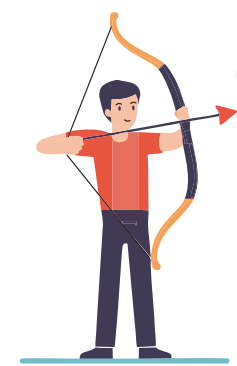

Four empty writing boxes for practicing the kanji '弓' (yumi).

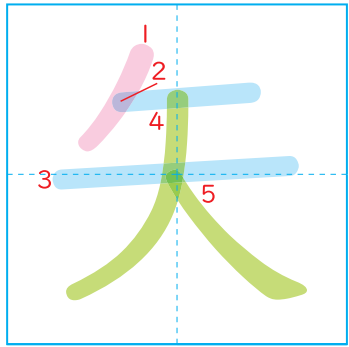

・ むかしの 弓^{ゆみ}矢^や。

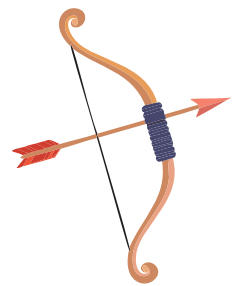

Four empty writing boxes for practicing the kanji '矢' (ya).

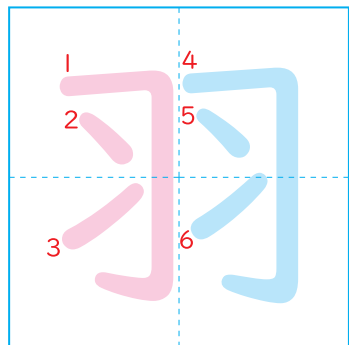

・ 鳥とりの

羽はね。



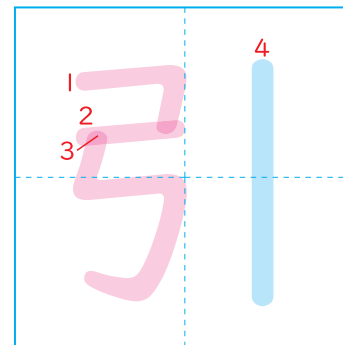

・ つなを

引ひく。



ゆっくり ていねいに、わくの 中なかに 書かきましょう。



かん字じの れんしゅう②〇 「引・羽」

なまえ



かん字のれんしゅう⑳ 「会・回」

なまえ



ゆっくり ていねいに、わくの 中に 書きましょう。

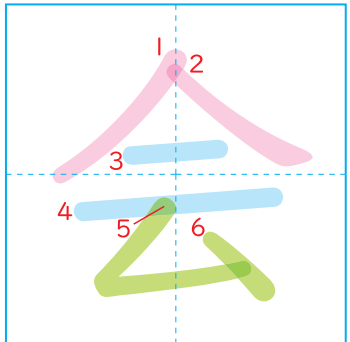

・ 人^{ひと}に 会^あう。

・ おたのしみ会^{かい}



Four empty boxes for writing practice, each with a pink outer border and a blue inner border, and a dashed horizontal line.

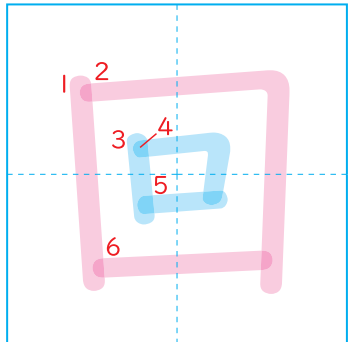

・ 三^{さん}回^{かい} 書^かく。

・ こまを 回^{まわ}す。

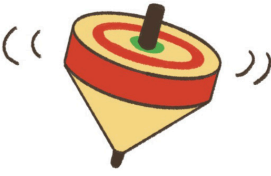

Four empty boxes for writing practice, each with a pink outer border and a blue inner border, and a dashed horizontal line.

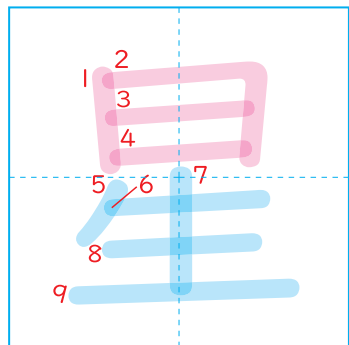

・
星^{ほし}
が

光^{ひか}
る。



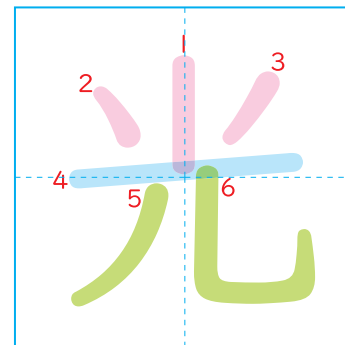

・
日^{にっこう}
光
が

まぶしい。

・
お日^ひさまの

光^{ひかり}。

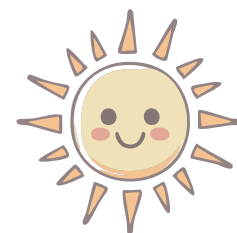

ゆっくり ていねいに、わくの
中^{なか}に 書^かきましよう。



かん字^じの
れんしゅう② 「光・星」

なまえ



かん字の れんしゅう ㊸ 「言・寺」

なまえ



ゆっくり ていねいに、わくの 中に 書きましょう。

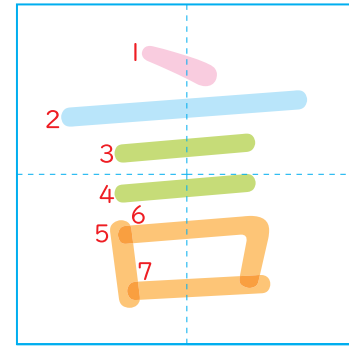

名前を 言う。



Four empty writing boxes for practicing the kanji '言' (koto).

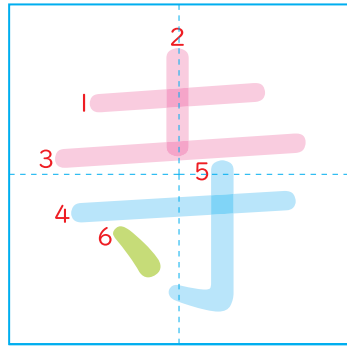

大きな お寺。



Four empty writing boxes for practicing the kanji '寺' (tera).



かん字のれんしゅう②④【時・自】

なまえ

ゆっくり ていねいに、わくの 中に 書きましょう。

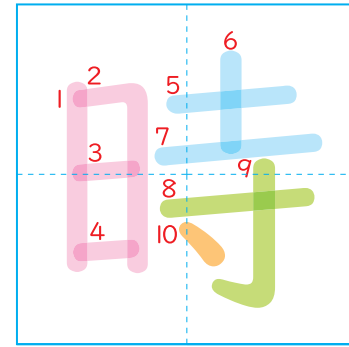



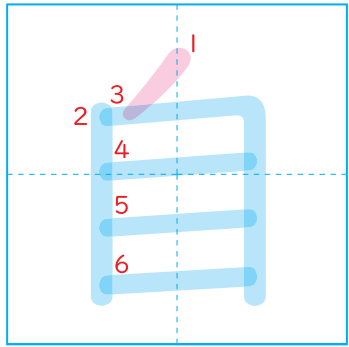

・六時に おきる。
・時が たつ。

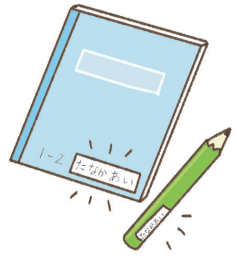

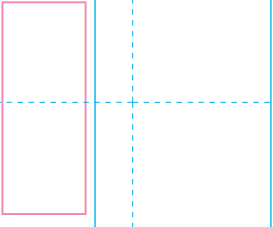
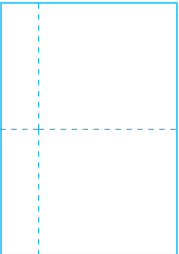
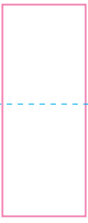
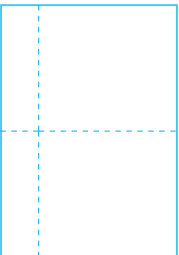
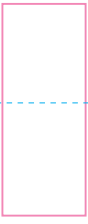
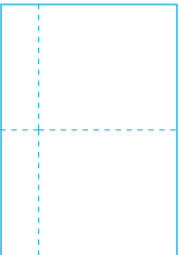
・自分の 名前。
・自ぜんを まもる。

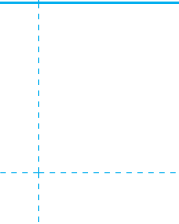



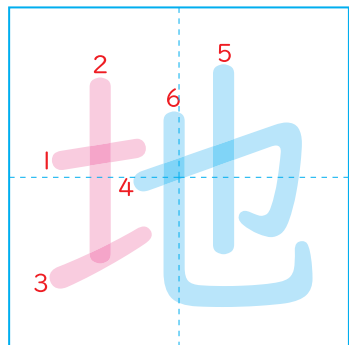



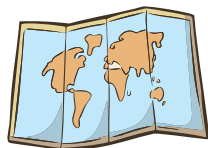

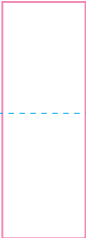
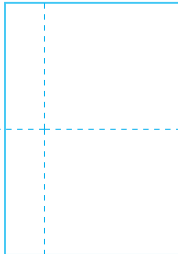

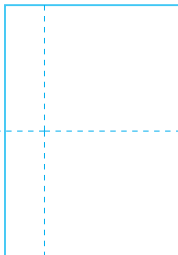

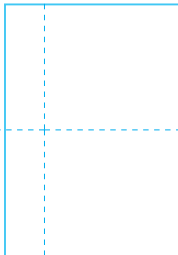
・ 地^じしんがくる。
 ・ せかい^ち地^ず図^みを見る。

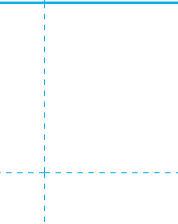

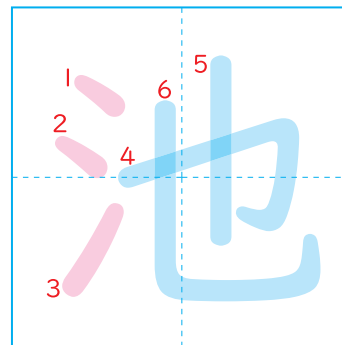

・ 小^ちさな池^い。

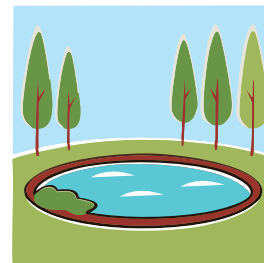

ゆっくり ていねいに、わくの
 中^{なか}に 書^かきましよう。



かん字^じの れんしゅう ⑳ 「池・地」

なまえ



かん字のれんしゅう②⑥【当・同】

なまえ



ゆっくり ていねいに、わくの 中なかに 書かきましよう。

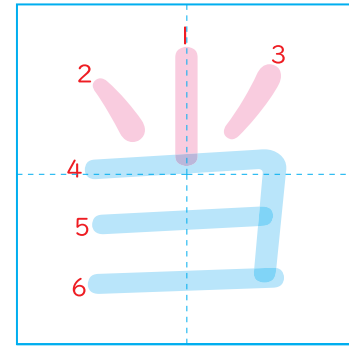

・ 日ひが 当あたる。
・ 本ほん当とうの 話はなし。



Four empty boxes for writing practice, each divided into four quadrants by a vertical and a horizontal dashed line.

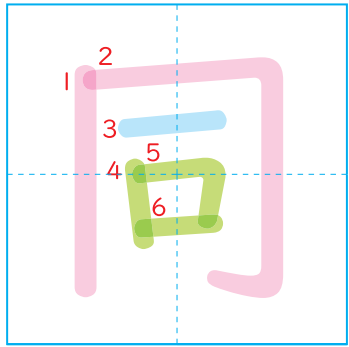

・ 同おなじ ぼうし。



Four empty boxes for writing practice, each divided into four quadrants by a vertical and a horizontal dashed line.

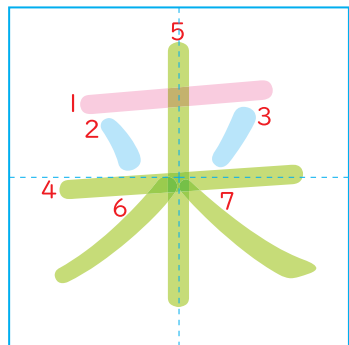

・人が ひと 来る。
 ・来月 らいげつ のカレンダー。

9月						
日	月	火	水	木	金	土
					1	2
3	4	5	6	7	8	9
10	11	12	13	14	15	16
17	18	19	20	21	22	23
24	25	26	27	28	29	30

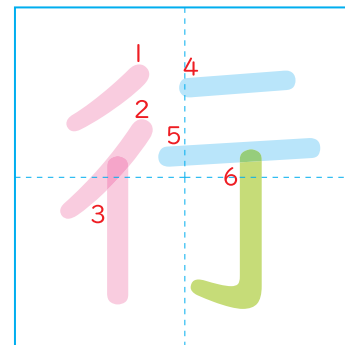

・学校 がっこう に
 行く。

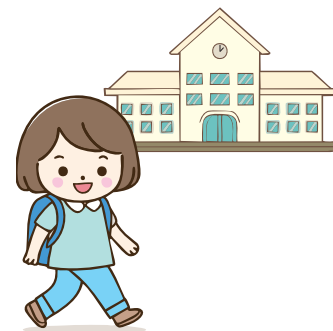

ゆっくり ていねいに、わくの なか 中に か 書きましょう。



かん字 じ の れんしゅう ⑳ 「行・来」

なまえ

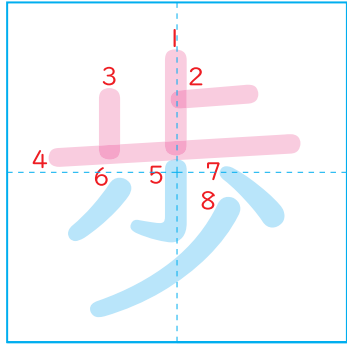

・
ね
こ
が

ある
歩
く。



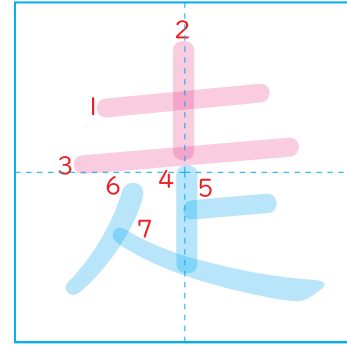

・
犬
が

は
し
る。

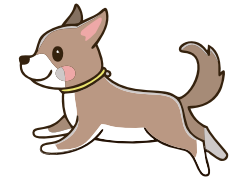

ゆっくり
ていねいに、
わくの
中
に
書
き
ま
し
よ
う。



かん
字
の
れ
ん
し
ゅ
う
⑳
「
走
・
歩
」

な
ま
え



かん字の れんしゅう ㊹ 「作・食」

なまえ

ゆっくり ていねいに、わくの 中に 書きましょう。

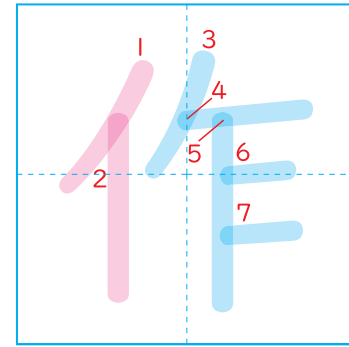

・ 文^{ぶん}を 作^{つく}る。

・ 作^{さくぶん}文^{ぶん}を 書^かく。



Four empty writing boxes for practicing the kanji '作' (shaku).

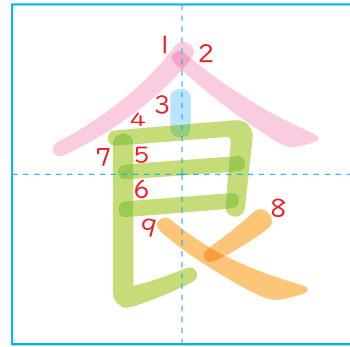

・ カレーを 食^たべる。

・ おいしい 夕^{ゆう}食^{しょく}。

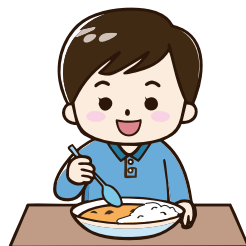

Four empty writing boxes for practicing the kanji '食' (shoku).

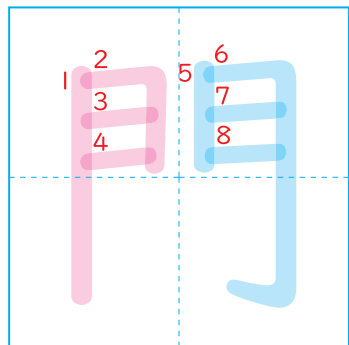

・ 家の門。

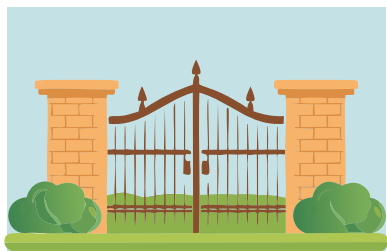

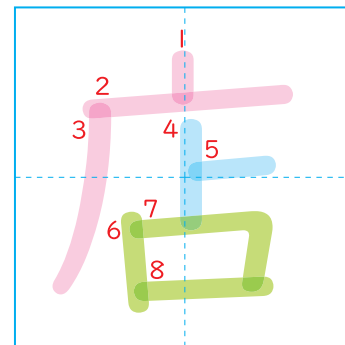

・ 店内をさがす。
・ 店で買う。



ゆっくりと書いて、わくの
中に書きましょう。



かんじのれんしゅう③〇【店・門】

なまえ



かん字のれんしゅう③「売・買」

なまえ

ゆっくりていねいに、わくの
中に書きましょう。

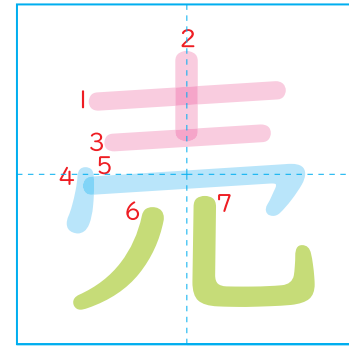

パンを
えきの
売店。
売る。

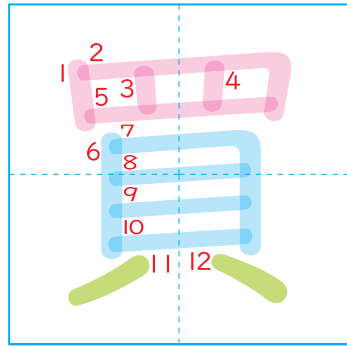

パンを
買う。
魚を
売買する。



Blank handwriting practice area with a vertical dashed line and horizontal dashed lines for the middle and bottom of the character.

Blank handwriting practice area with a vertical dashed line and horizontal dashed lines for the middle and bottom of the character.



かん字のれんしゅう③②【毎・海】

なまえ



ゆっくりていねいに、わくの
中に書きましょう。

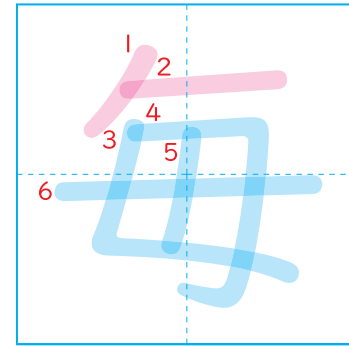

毎日れんしゅうする。





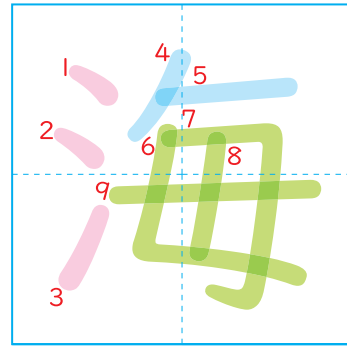

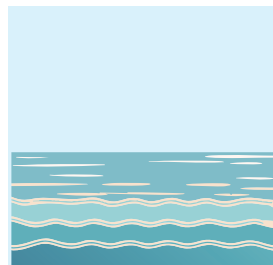

Four vertical writing practice boxes with dashed lines for alignment.



きれいな海。
海がなを歩く。



Four vertical writing practice boxes with dashed lines for alignment.

	
	
	

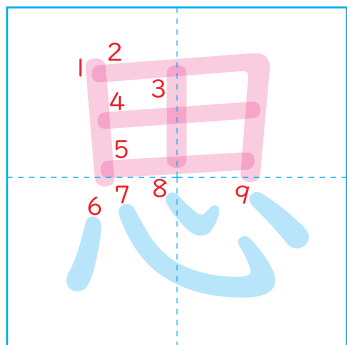

・うれしいと
 ・思う。^{おも}



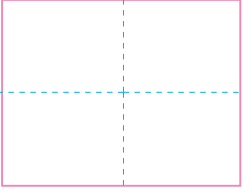
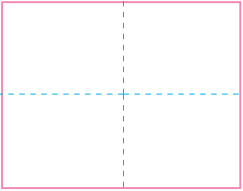
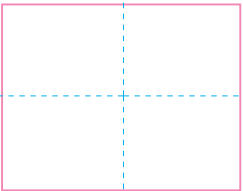

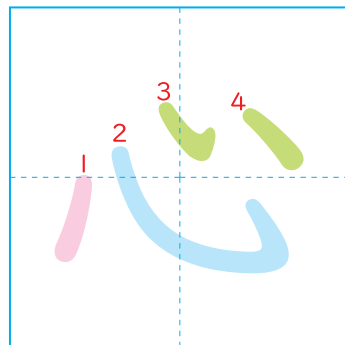
・町の^{まち}
 ・やさしい^{こころ}。
 ・中心^{ちゅうしん}。



ゆっくりていねいに、わくの^{なか}中に^か書きましょう。



かん字^じのれんしゅう③③【心・思】

なまえ

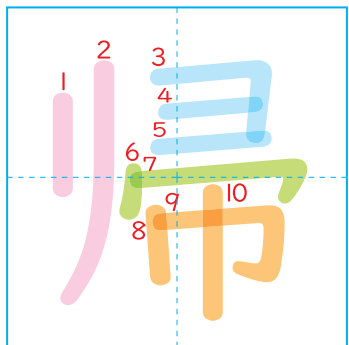

いそいで

帰る。



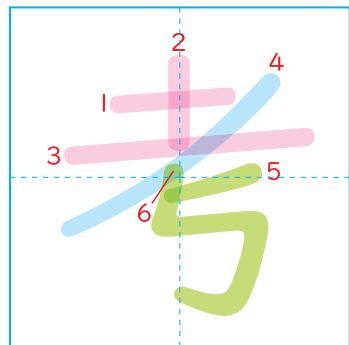

答えを

考える。









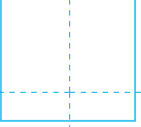

ゆっくりていねいに、わくの
中に
書きましょう。

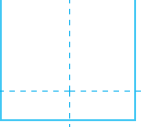

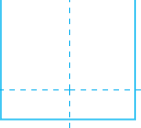
かん字の
れんしゅう③④
【考・帰】

なまえ

  
  
  
  

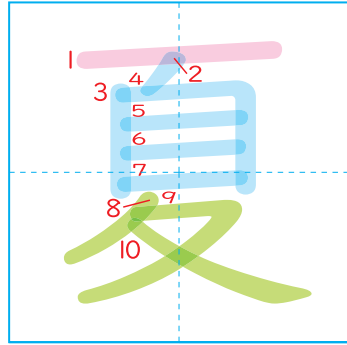

・ 夏^{なつ}
の

海^{うみ}。



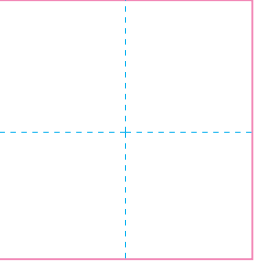
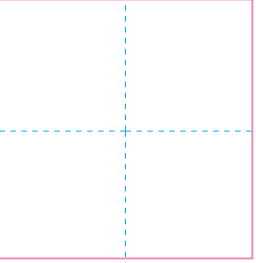
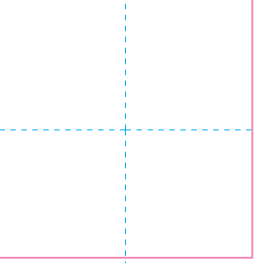
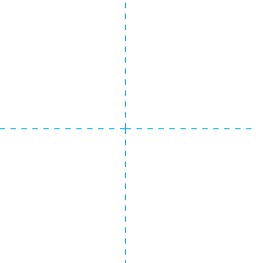

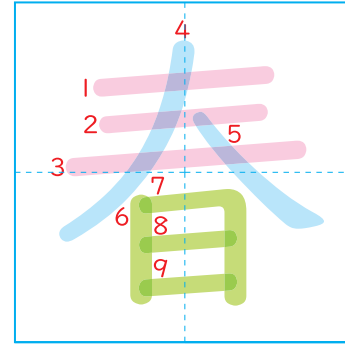
・ 春^{はる}
に

なる。



ゆっくり ていねいに、わくの 中^{なか}に 書^かきましよう。



かん字^じの れんしゅう ③⑤ 「春・夏」

なまえ

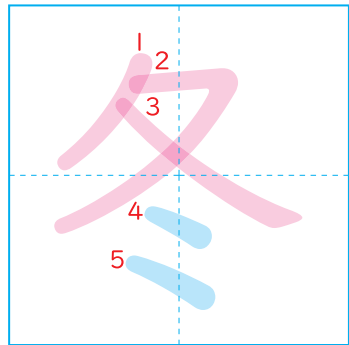

・さむい

冬ふゆ。



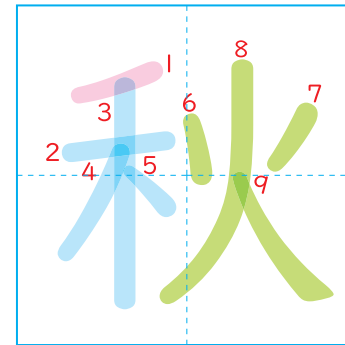

・秋あきの
けしき。



ゆっくり
ていねいに、
わくの
中なかに
書かきましよう。



かん字じの
れんしゅう36 「秋・冬」

なまえ

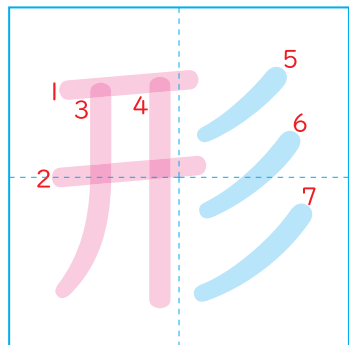

・クツキーの形かたち。
 ・人形にんぎょうであそぶ。



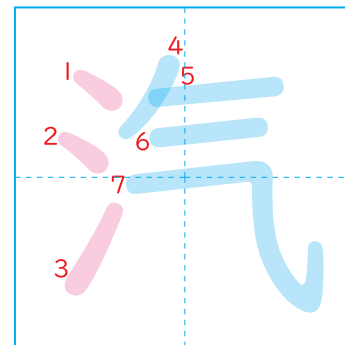

・汽車きしゃが走るはしる。



ゆっくりていねいに、わくの中になか書きましよう。



かん字じのれんしゅう③⑦「汽・形」

なまえ

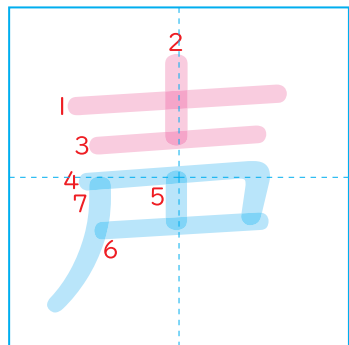

・きれいな
声こえ。



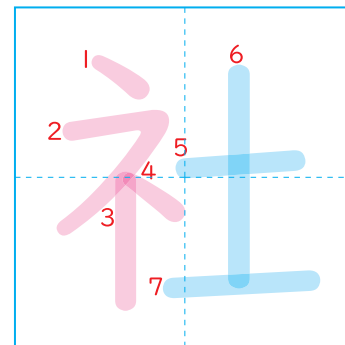

・会社かいしゃで
はたらく。



ゆっくり
ていねいに、わくの
中なかに
書かきましよう。



かん字じの
れんしゅう③⑧
〔社・声〕

なまえ

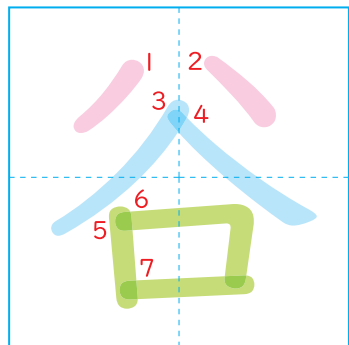

・ 谷 たにがわ の 水 みず。

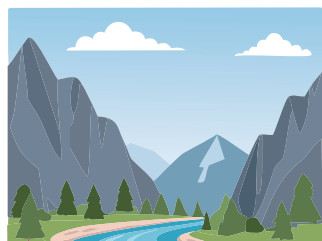

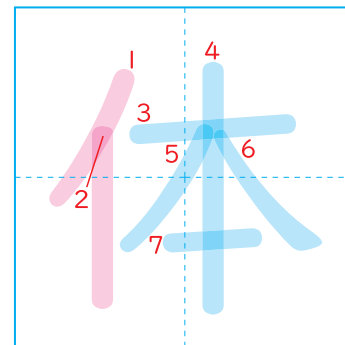

・ 人 ひと の 体 からだ。
 ・ 体 たい そうを する。



ゆっくり ていねいに、わくの 中 なか に 書 か きましよう。



かん字 じ の れんしゅう ③⑨ 「体・谷」

なまえ



かん字のれんしゅう④〇「色・里」

なまえ



ゆっくりていねいに、わくの
中に書きましょう。

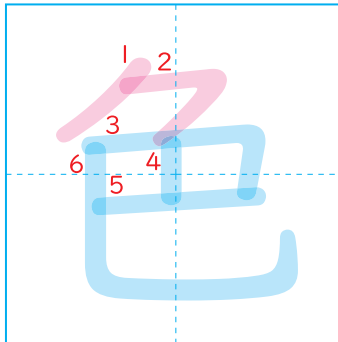

いろいろな色。

三色のはた。

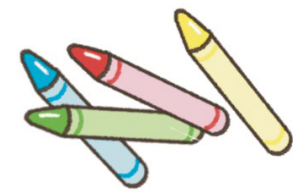

Four vertical writing practice boxes, each containing a pink rectangle in the top half and a blue rectangle in the bottom half, for practicing the kanji '色'.

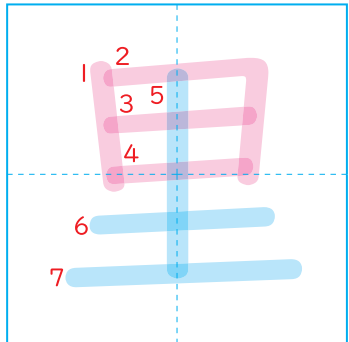

里いもを
食べる。

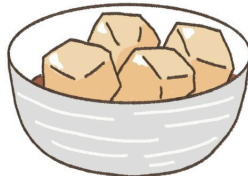

Four vertical writing practice boxes, each containing a pink rectangle in the top half and a blue triangle in the bottom half, for practicing the kanji '里'.

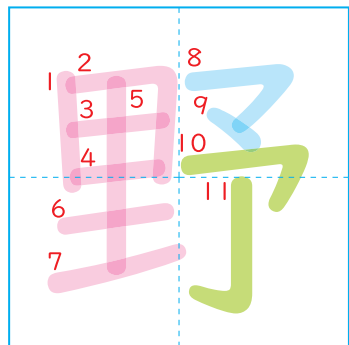

・ 野^やさいを食^たべる。
 ・ 野^の山^{やま}を歩^{ある}く。

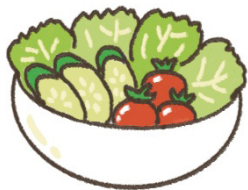

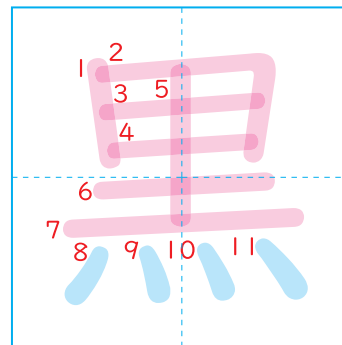

・ 黒^{こく}ばんに書^かく。
 ・ 黒^{くろ}い色^{いろ}。



ゆっくり ていねいに、わくの
 中^{なか}に 書^かきましよう。



かん字^じの れんしゅう ④ 「黒・野」

なまえ

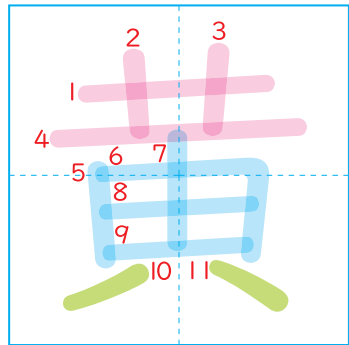

・
黄色きいろ
い

花はな
。



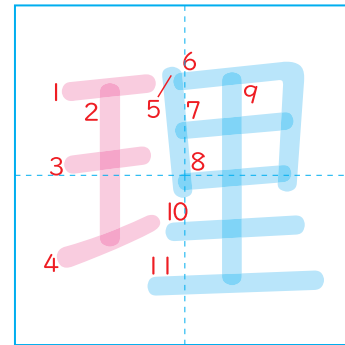

・
りよう理り
を
する。



ゆっくり
ていねいに、
わくの
中なかに
書かきましよう。



かん字じの
れんしゅう④
【理・黄】

なまえ

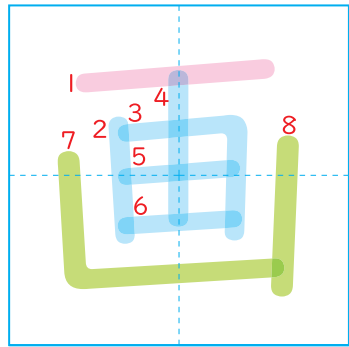

・ **画**^が **用紙**^{ようし} **に** **か**^く。
 ・ **五**^ご **画**^{かく} **の** **か**^ん **字**^じ。



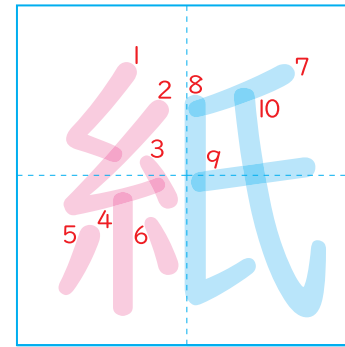

・ **白**^{しろ} **い**
紙^{かみ}。

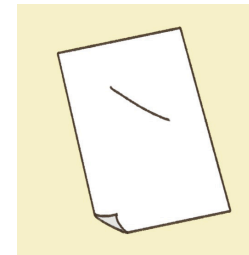

ゆっくり ていねいに、わくの **中**^{なか} **に** **書**^か **き** **ま** **し** **よ** **う**。



かん字^じの れんしゅう ④③ 「紙・画」

なまえ

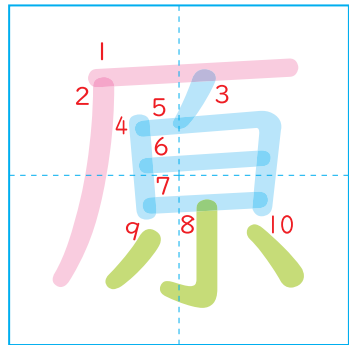

・ 春^{はる}の
 ・ 野^の原^{はら}。
 ・ 広^{ひろ}い
 ・ 草^{そう}原^{げん}。

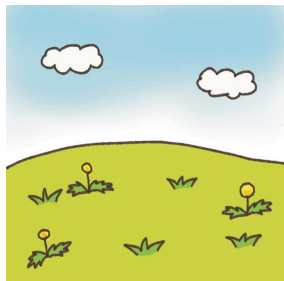

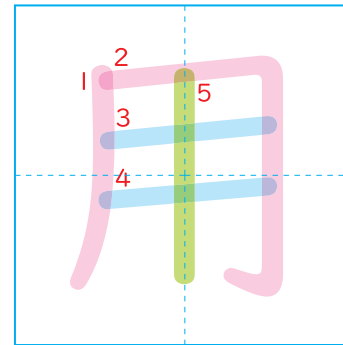

・ 画^が用^{よう}紙^しに
 かく。



ゆっくり
 ていねいに、
 わくの
 中^{なか}に
 書^かきましよう。



かん字^じの
 れんしゅう④④
 「用・原」

なまえ



かん字のれんしゅう④⑤ 「国・語」

なまえ

ゆっくりていねいに、わくの
中に書きましょう。

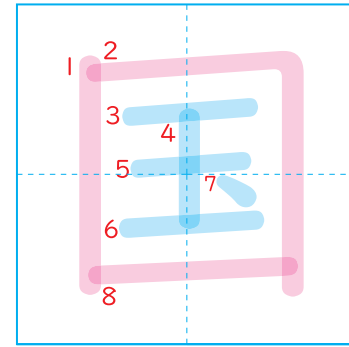

いろいろな国。
外国人。



Handwriting practice grid for the kanji '国' (country). It consists of four rows. The first two rows have a pink outer square and a blue inner square. The last two rows are empty for practice.

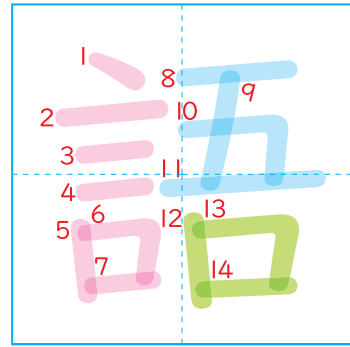

もの語をよむ。
国語のじゆぎよう。



Handwriting practice grid for the kanji '語' (language). It consists of four rows. The first two rows have a pink outer rectangle and a blue inner rectangle. The last two rows are empty for practice.



かん字のれんしゅう④⑥ 「計・工」

なまえ

ゆっくり ていねいに、わくの 中に 書きましょう。

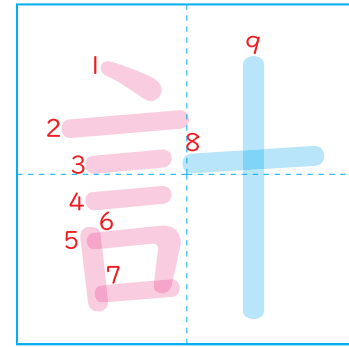

・ おんど計けい
・ 時間じかんを 計はかる。

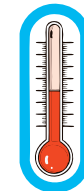

Four sets of handwriting practice boxes, each consisting of a large pink rectangle on the left and a smaller blue rectangle on the right, all within a blue grid.

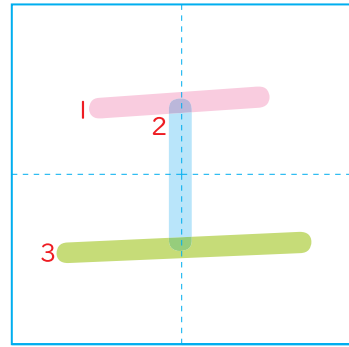

・ 大だい工こうさん
・ 工こう作さくを する。



Four sets of handwriting practice boxes, each consisting of a large pink rectangle on the left and a smaller blue rectangle on the right, all within a blue grid.



かん字のれんしゅう④⑦【算・数】

なまえ

ゆっくりていねいに、わくの
中に書きましょう。

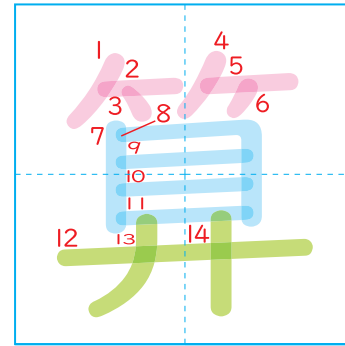

計算をする。

たし算

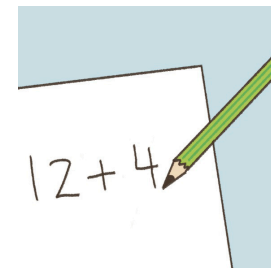

Four sets of empty boxes for writing practice, each consisting of a top box, a middle box, and a bottom box, separated by dashed lines.

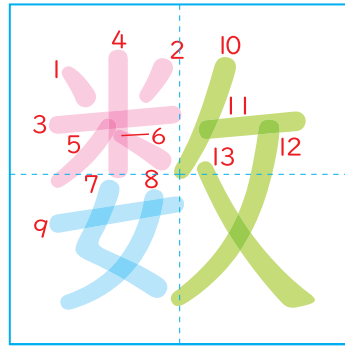





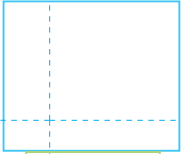

数を数える。

算数のじゆぎょう。



Four sets of empty boxes for writing practice, each consisting of a top box, a middle box, and a bottom box, separated by dashed lines.

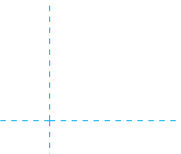

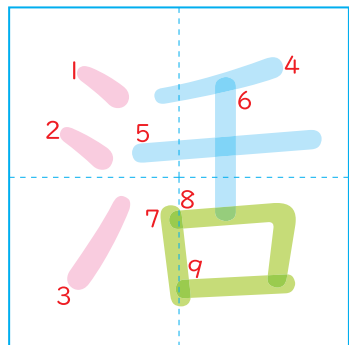

・ 毎まい日にちの

生せい活かつ。



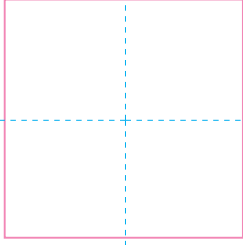
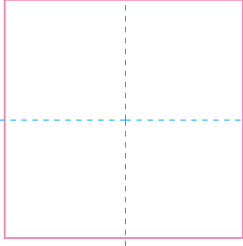
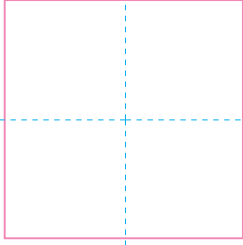
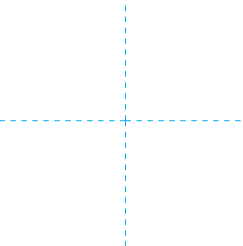

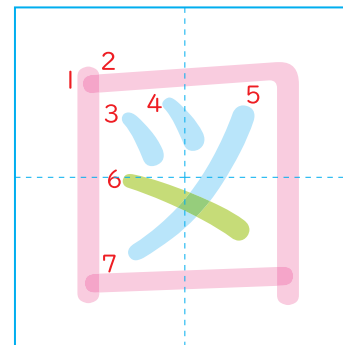
・ 図ず工こうの

時じ間かん。



ゆっくり ていねいに、わくの 中なかに 書かきましよう。



かん字じの れんしゅう ④⑧ 「図・活」

なまえ

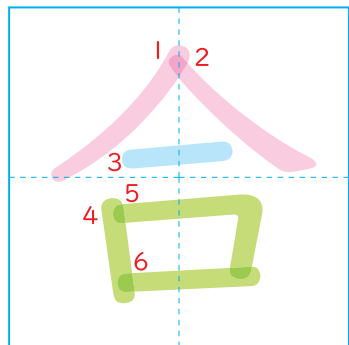

・ 気^きが
 ・ 合^あう。
 ・ 合^{ごう}計^{けい}の
 ・ ねだん。



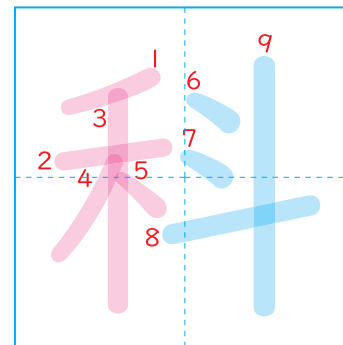

・ 生^{せい}活^{かつ}科^かの
 ・ 教^{きょう}科^か書^{しょ}。



ゆっくり
 ていねいに、
 わくの
 中^{なか}に
 書^かきましよう。



かん字^じの
 れんしゅう ④
 「科・合」

なまえ



かん字のれんしゅう⑤〇「交・何」

なまえ



ゆっくりていねいに、わくの
中に書きましょう。

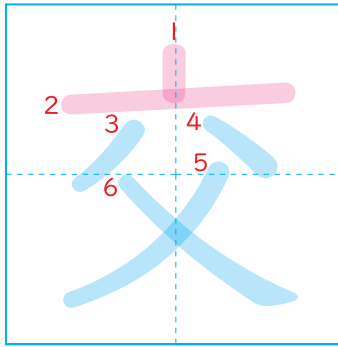

・ 交^{こう}さ^{てん}点をわたる。
・ 石^{いし}が交^まざる。

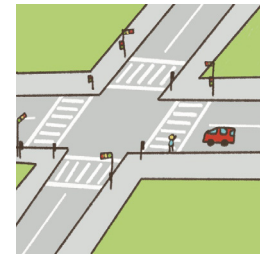

Four vertical writing boxes for practicing the character '交'. Each box has a dashed midline and a pink rectangular box at the top for the first stroke.

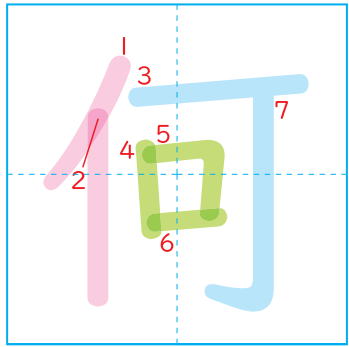

・ 何^{なに}もない。
・ 何^{なん}日^{にち}もまつ。

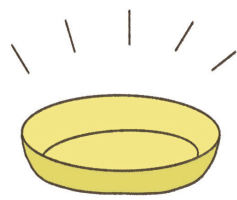

Four vertical writing boxes for practicing the character '何'. Each box has a dashed midline and a pink rectangular box on the left and a green square box on the right for the first two strokes.

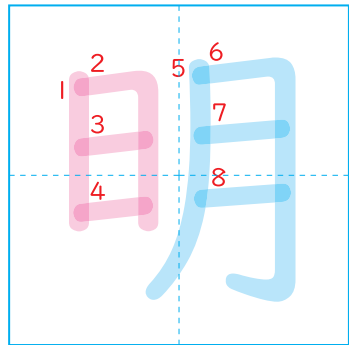

・
明^{あか}
る
い
 へ
や。



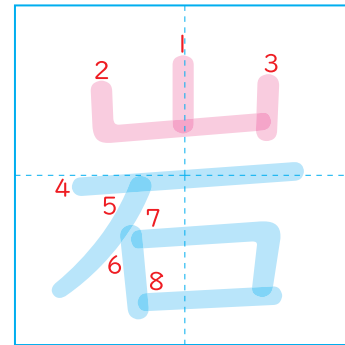

・
大^{おお}
きな
岩^{いわ}
。

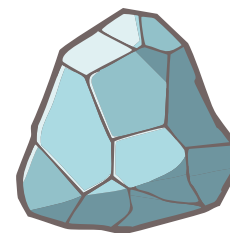

ゆっくり
 ていねいに、わくの
 中^{なか}に
 書^かきましょう。



かん字^じの
 れんしゅう⑤
 「岩・明」

なまえ

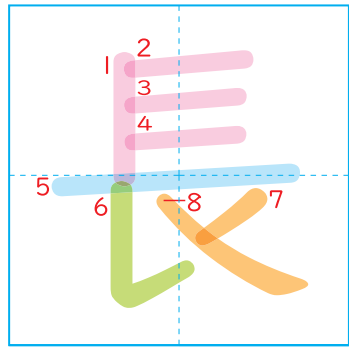

・ 長い なが
 ・ お店の みせ 店長 てんちやう。
 ・ しっぽ。



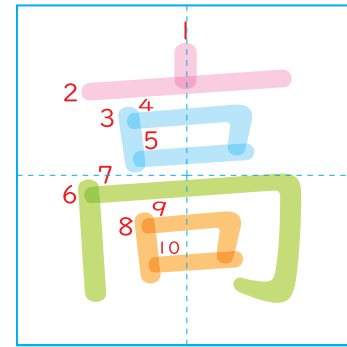

・ 高い たか
 たてもの。



ゆっくり ていねいに、わくの なか 中に か 書きましょう。



かん字 じ の れんしゆう ⑤2 「高・長」

なまえ



かん字の れんしゅう ⑤③ 「首・直」

なまえ



ゆっくり ていねいに、わくの 中に 書きましょう。

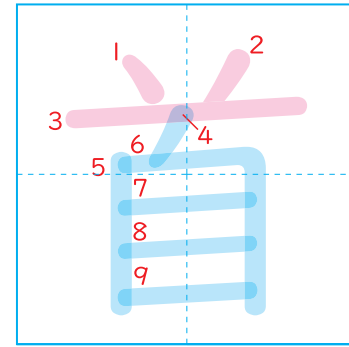

・きりんの 首。

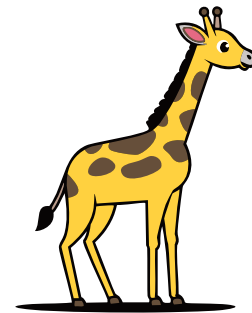

Four vertical writing practice boxes for the kanji '首'. Each box has a pink top rectangle and a blue bottom rectangle, with a dashed vertical line in the center. The bottom two boxes are empty for practice.

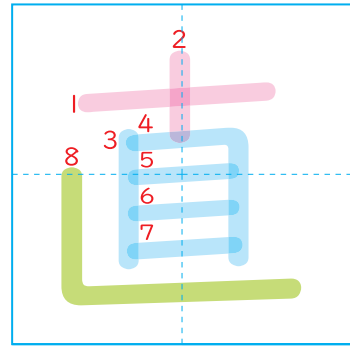

・まちがいを 直す。
・日直の しごと。



Four vertical writing practice boxes for the kanji '直'. Each box has a pink top rectangle and a blue bottom rectangle, with a dashed vertical line in the center. The bottom two boxes are empty for practice.



かん字のれんしゅう⑤4 「前・後」

なまえ



ゆっくりていねいに、わくの
中に書きましょう。

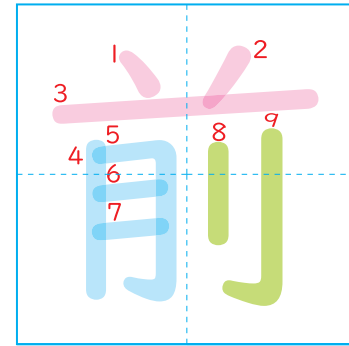

前をみる。

テストの前日。

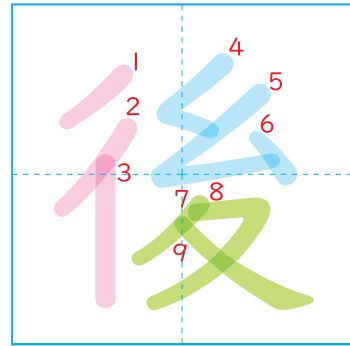
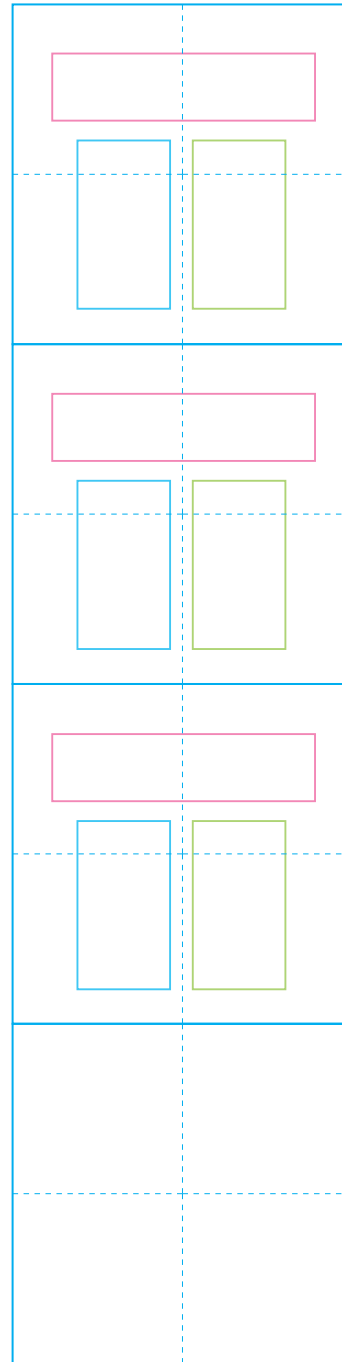

後かたづけをする。

前後をみる。

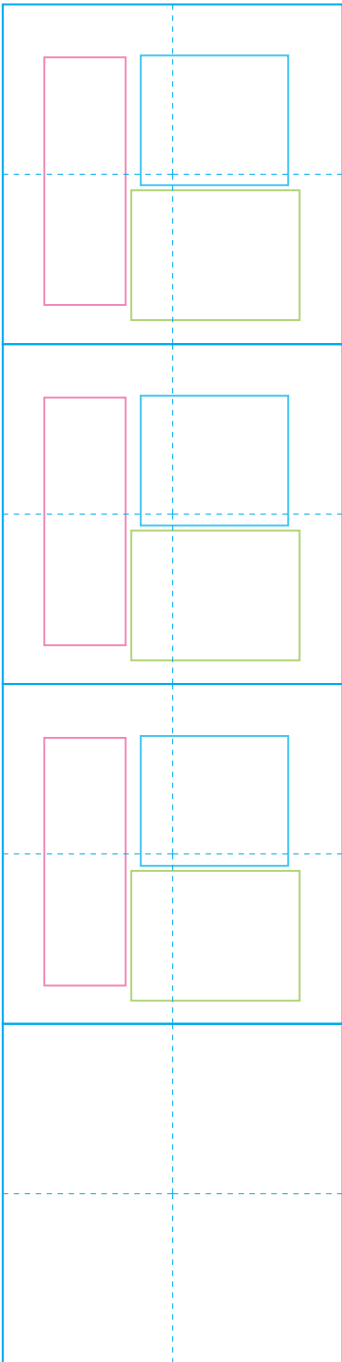

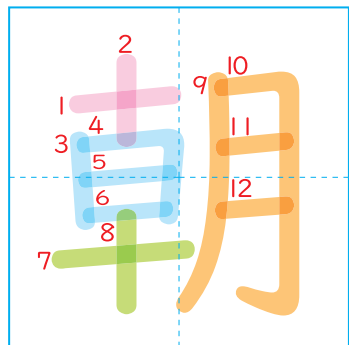

・ 朝食 ちようしよく
 ・ 朝ごはん あさごはん

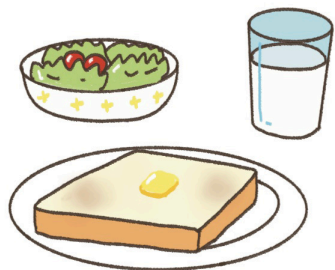

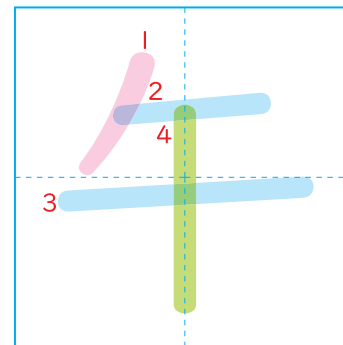

・ 午前中の天気。
ごぜんちゆうの てんき。

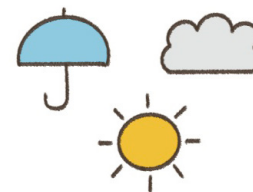

ゆっくり ていねいに、わくの
 中に なか 書きましよう。
か



かん字の じ れんしゆう ⑤⑤ 「午・朝」

なまえ



かん字のれんしゅう⑤⑥ 「昼・夜」

なまえ

ゆっくり ていねいに、わくの
中に
書きましょう。

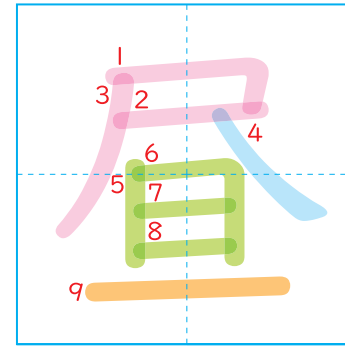

・ 昼ひるごはん
・ 昼食ちゆうしょく



Four empty boxes for writing practice, each divided into four quadrants by a vertical and a horizontal dashed line.

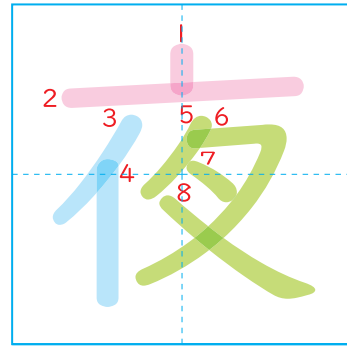

・ 夜よるになる。
・ 夜中よなかにおきる。



Four empty boxes for writing practice, each divided into four quadrants by a vertical and a horizontal dashed line.

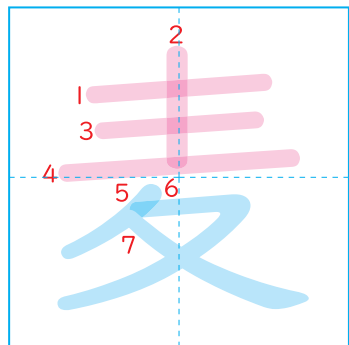

・ 麦茶を のむ。



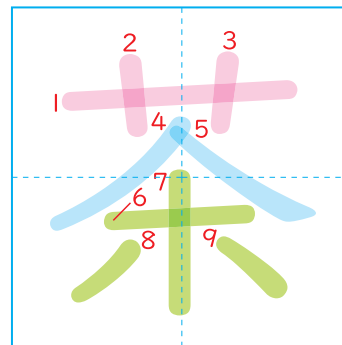

・ 茶色の 色えんぴつ。

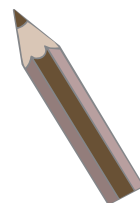

ゆっくり ていねいに、わくの 中に 書きましょう。



かん字の れんしゅう ⑤ 「茶・麦」

なまえ

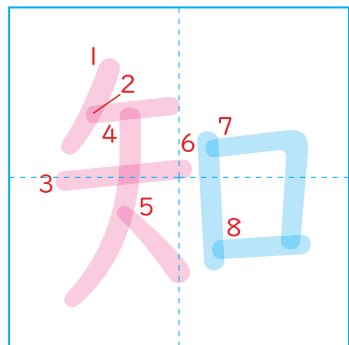

先生^{せんせい}に
知^しらせる。

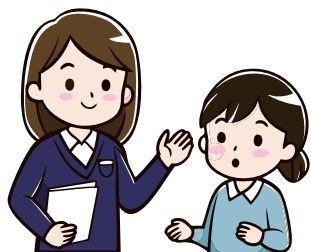

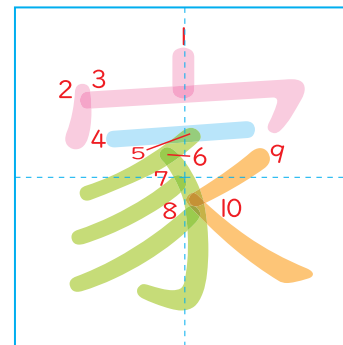

家^{いえ}に
帰^{かえ}る。
三人^{さんにん}家^かぞく

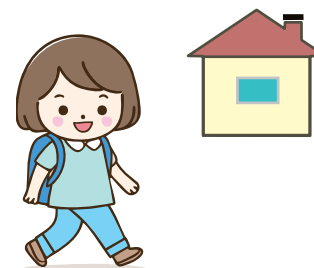

ゆっくり
ていねいに、
わくの
中^{なか}に
書^かきましょう。



かん字^じの
れんしゅう
⑤⑧ 「家・知」

なまえ

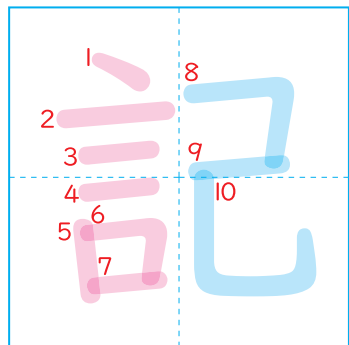

・ 日記^{にっき}を
書^かく。



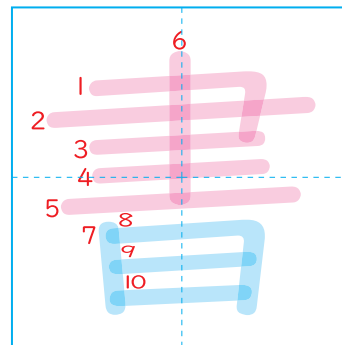

・ 本^{ほん}の
書名^{しょめい}。
・ かん字^じを
書^かく。

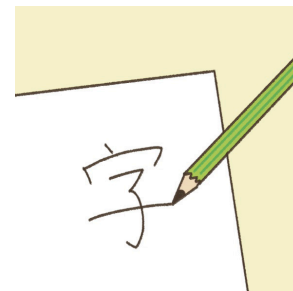

ゆっくり ていねいに、わくの 中^{なか}に 書^かきましょう。



かん字^じの れんしゅう ⑤ 「書・記」

なまえ

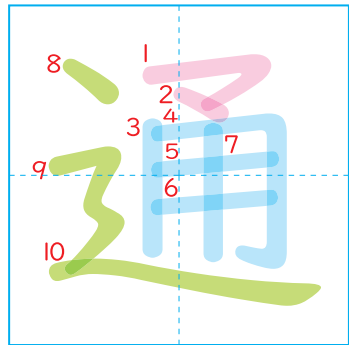

・ 学校がっこうに
 通かよう。
 ・ 人ひとが
 通とおる。



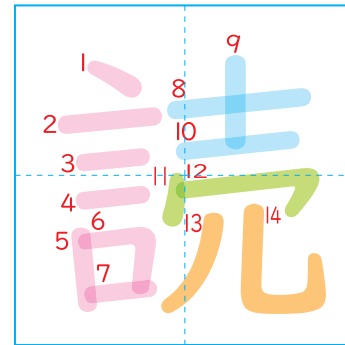

・ 読どく書しよを
 する。
 ・ 本ほんを
 読よむ。



ゆっくり ていねいに、わくの
 中なかに 書かきましよう。



かん字じの
 れんしゆう⑥0 「読・通」

なまえ



かん字のれんしゅう⑥①【教室】

なまえ

ゆっくり ていねいに、わくの 中に 書きましょう。

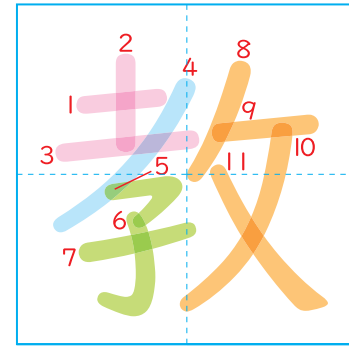

かん字を教える。
いろいろな教科。

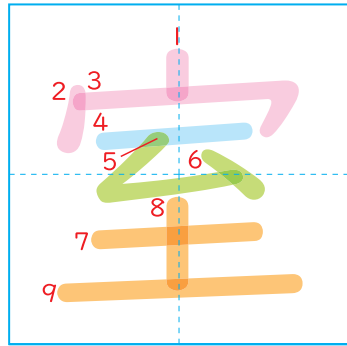

きょうしつ
教室に
はい
入る。

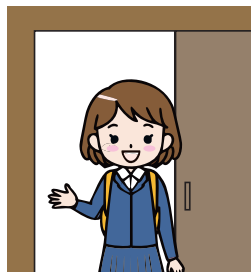

Three sets of empty handwriting practice boxes, each with a pink border and a dashed blue midline.

Three sets of empty handwriting practice boxes, each with a pink border and a dashed blue midline.

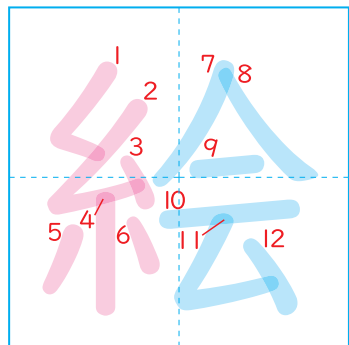

・ 絵^えを
見る^みる。

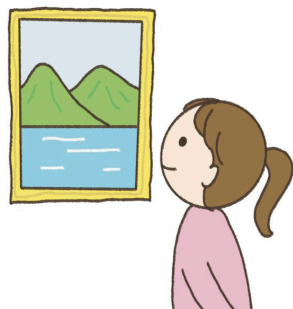

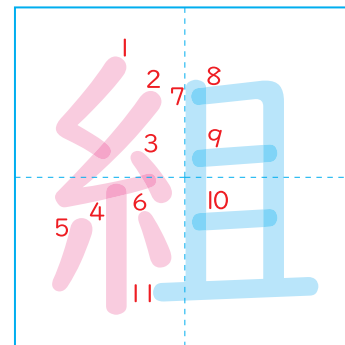

・ 二^に年^{ねん}一^{いち}組^{くみ}の
先^{せん}生^{せい}。



ゆっくり ていねいに、わくの 中^{なか}に 書^かきましよう。



かん字^じの れんしゅう ⑥2 「組・絵」

なまえ



かん字の れんしゅう ⑥③ 「間・聞」

なまえ



ゆっくり ていねいに、わくの 中に 書きましょう。

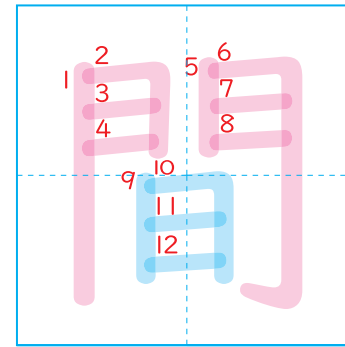

つくえの 間。

人間の 体。

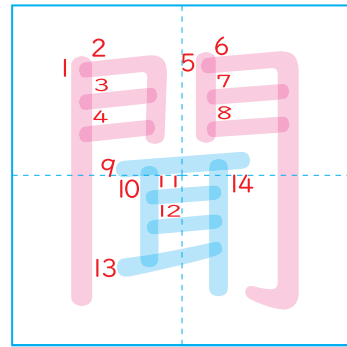
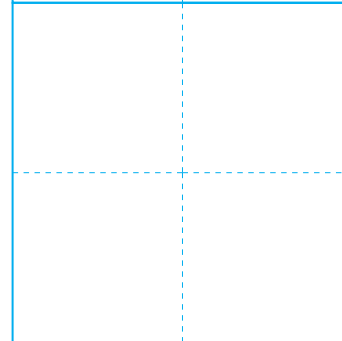
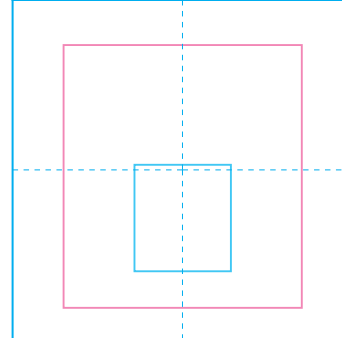
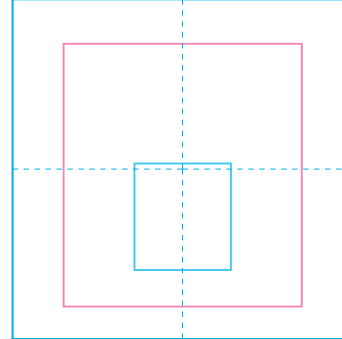
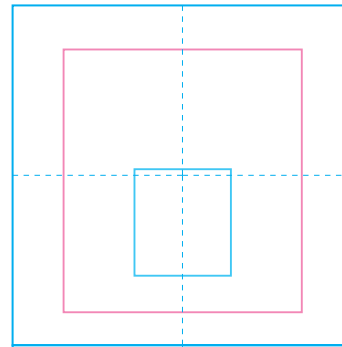
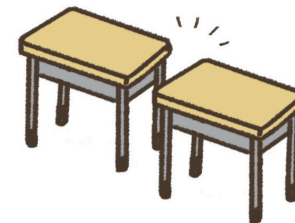

話を 聞く。

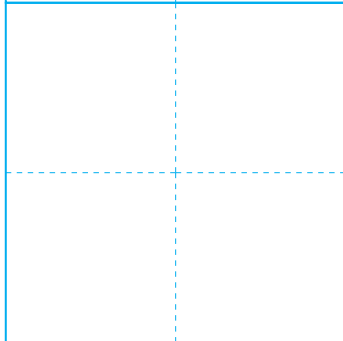
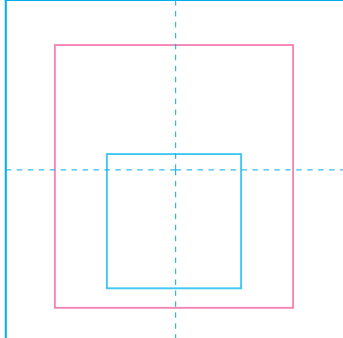
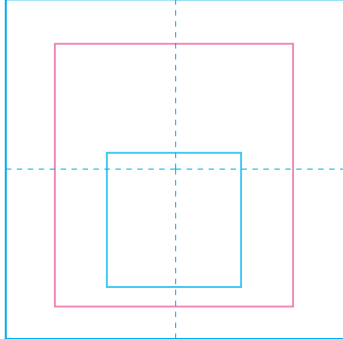
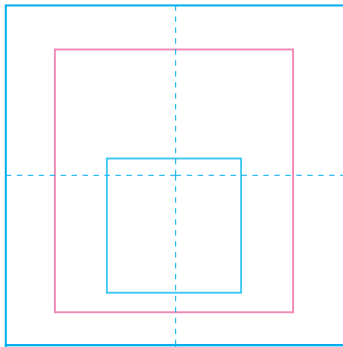



鉛筆
ゆっくりていねいに、わくの
中に
書きましよう。

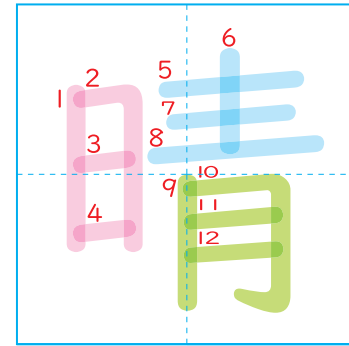

あしたは
晴れる。
晴天に
なる。

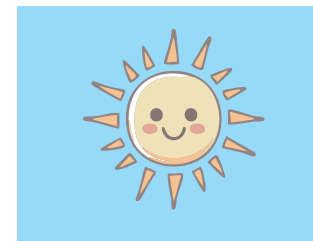

Handwriting practice grid with four rows. Each row contains a pink box on the left and a green box on the right, separated by a vertical dashed line. The top two rows also have a blue box above the green box.

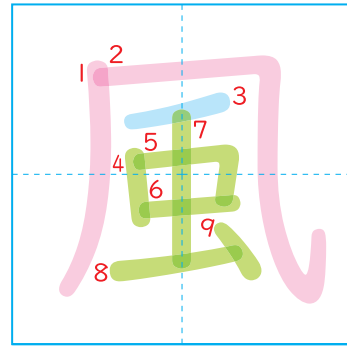

風が
ふく。
大きな
風車。

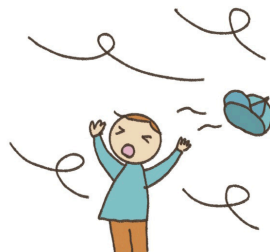

Handwriting practice grid with four rows. Each row contains a pink box on the left and a green box on the right, separated by a vertical dashed line.

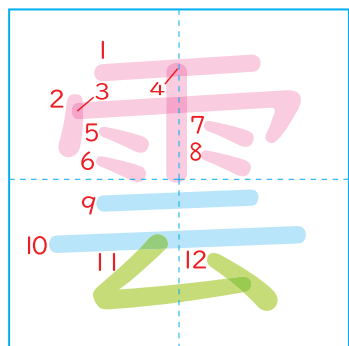

・ 白^{しろ}
い

・ 雲^{くも}
。

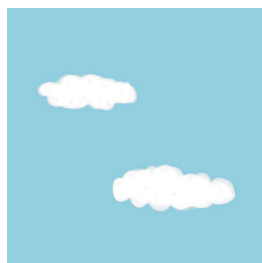

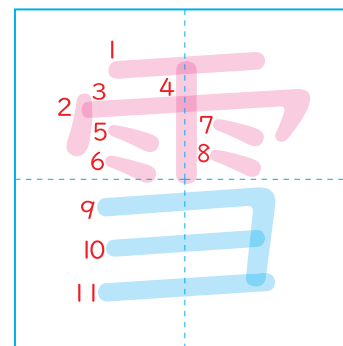

・ 雪^{ゆき}
が

・ ぶ
る。



ゆっくり ていねいに、わくの 中^{なか}に 書^かきましょう。



かん字^じの れんしゅう ⑥5 【雪・雲】

なまえ



かん字のれんしゅう⑥⑥【強・弱】

なまえ



ゆっくりていねいに、わくの
中に書きましょう。

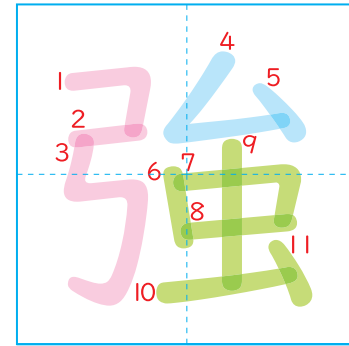

風が強い。
べん強をする。

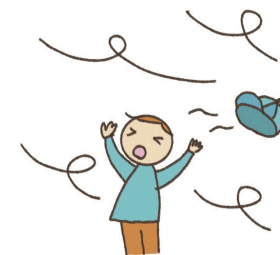

Handwriting practice grid with four rows. Each row contains a pink box on the left and a green box on the right, with a dashed vertical line in the middle. The bottom row is empty.

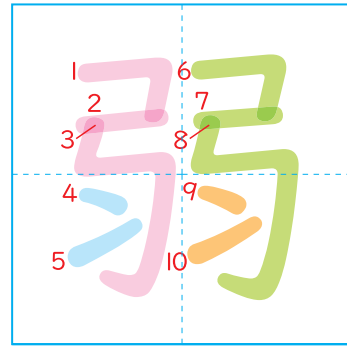

風が弱い。
強弱をつける。



Handwriting practice grid with four rows. Each row contains a pink box on the left and a green box on the right, with a dashed vertical line in the middle. The bottom row is empty.

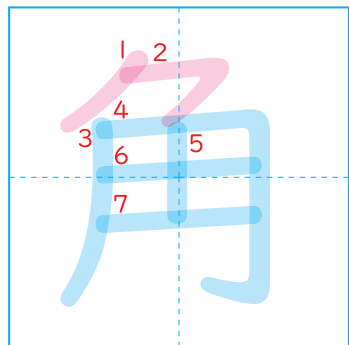

・ 道の みち
 ・ 牛の うし
 まがり角 かど
 角 つの



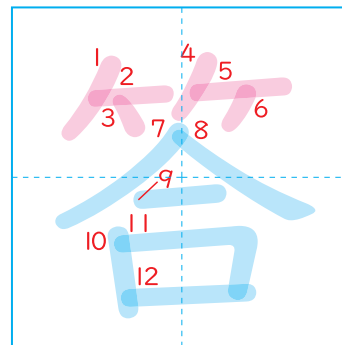

・ 答 こたえを
 言 いう。



ゆっくり ていねいに、わくの
 中 なかに 書 かきましよう。



かん字 じの れんしゅう ⑥7 「答・角」

なまえ

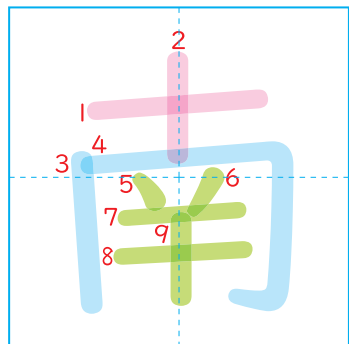

・
南みなみ
の

方角ほうかく
。

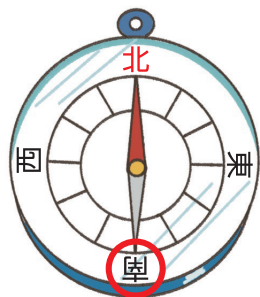

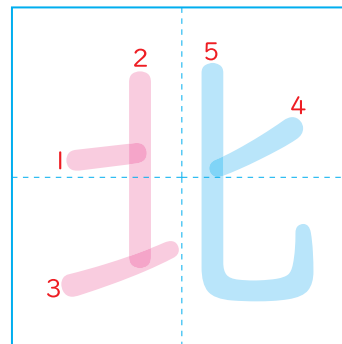

・
北きた
の

方角ほうかく
。

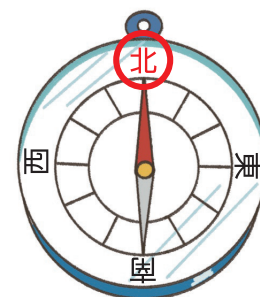

ゆっくり ていねいに、わくの
中なかに 書かきましよう。



かん字じの
れんしゅう ⑥⑧ 「北・南」

なまえ

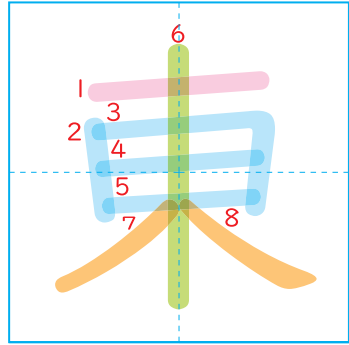

・ 東ひがしの

方角ほうかく。

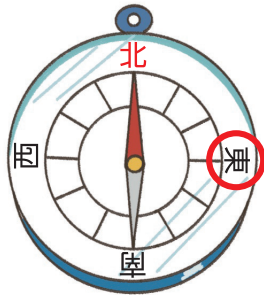

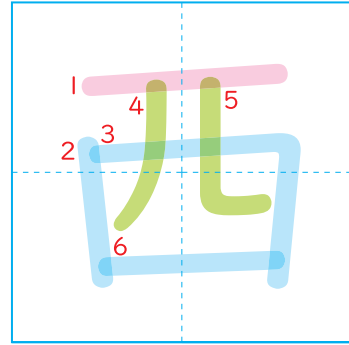

・ 西にしの

方角ほうかく。

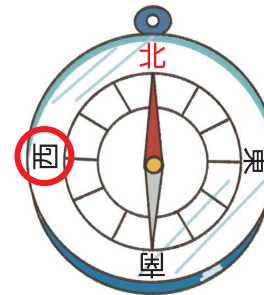

ゆっくり ていねいに、わくの 中なかに 書かきましよう。



かん字じの れんしゅう ⑥ 「西・東」

なまえ



かん字のれんしゅう⑦「番・道」

なまえ

ゆっくり ていねいに、わくの 中に 書きましょう。

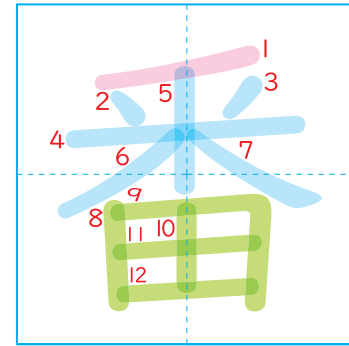

・ そうじ当番 (とうばん)



Handwriting practice grid for the kanji '番' (ばん) with four rows of boxes for tracing and writing.

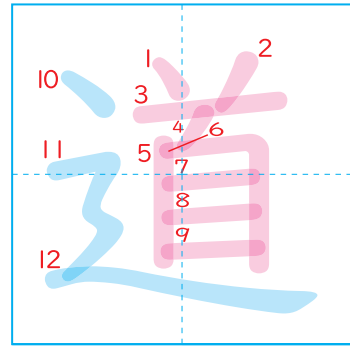

・ 広い (ひろい)
・ 歩道 (ほどう) を 歩く (あるく)。
・ 道 (みち)。

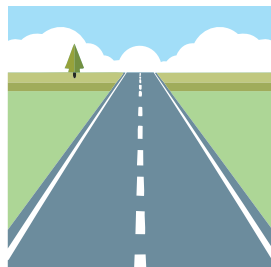

Handwriting practice grid for the kanji '道' (みち) with four rows of boxes for tracing and writing.

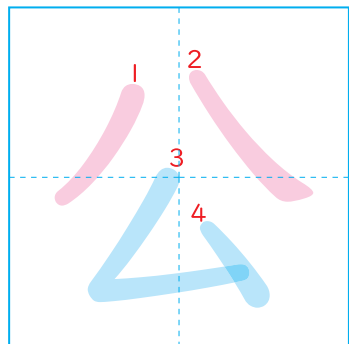
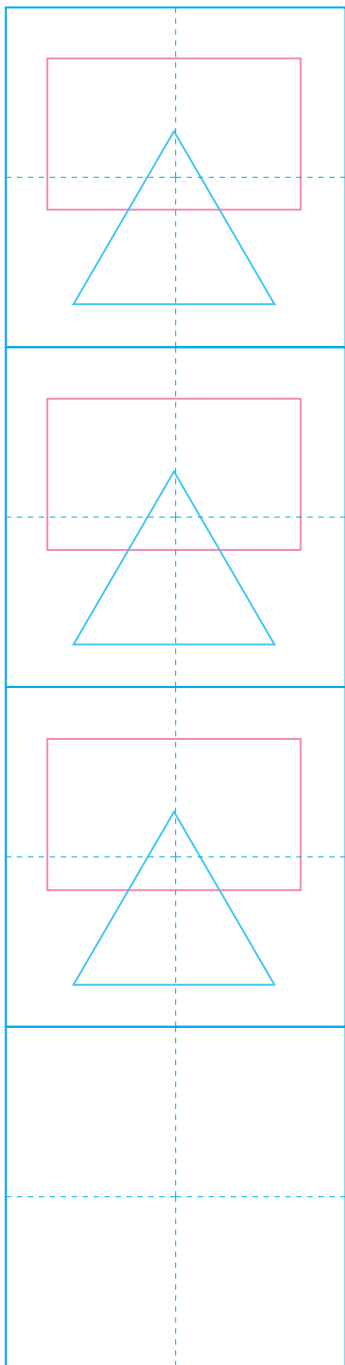

・
公園^{こうえん}
に
行く^{いく}。

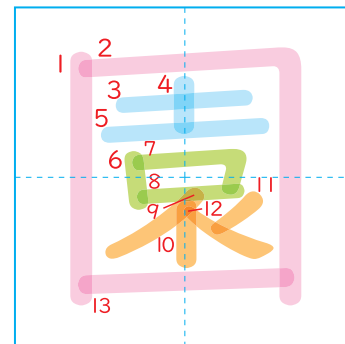
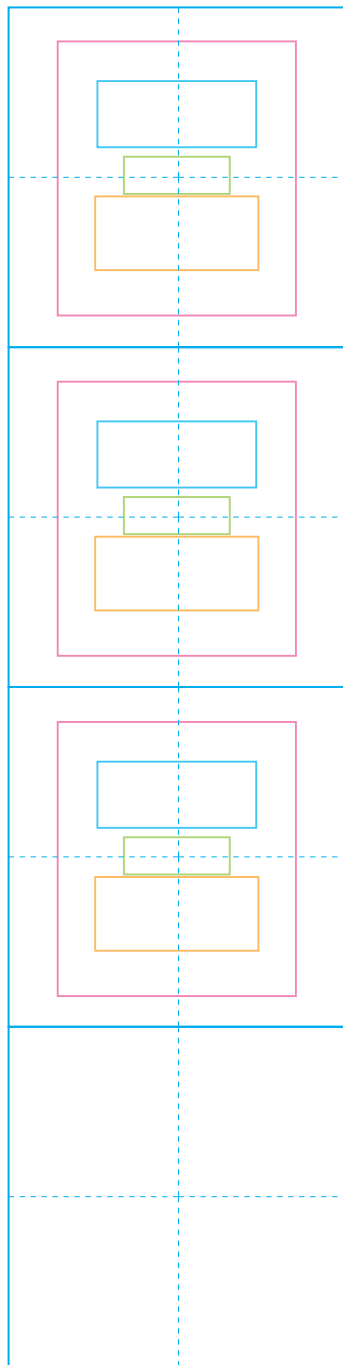

・
動物園^{だうぶつえん}



ゆっくり
ていねいに、
わくの
中^{なか}に
書^かきましよう。



かん字^じの
れんしゅう^{れんしゅう}の
⑦
「園・公」

なまえ



かん字のれんしゅう⑦②「近・遠」

なまえ



ゆっくりていねいに、わくの
中に
書きましょう。

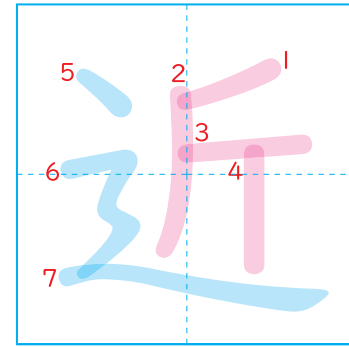

せきが
近い。

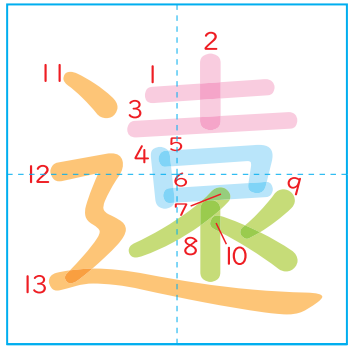
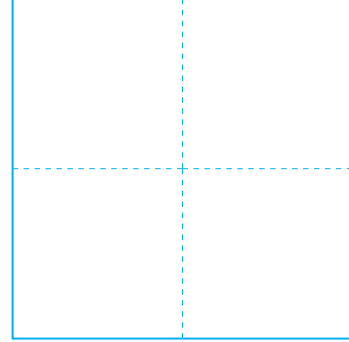
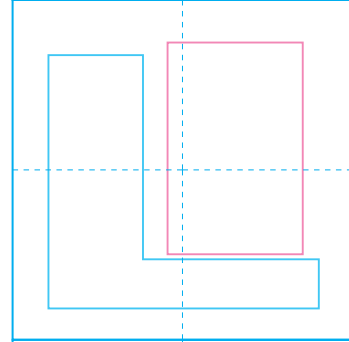
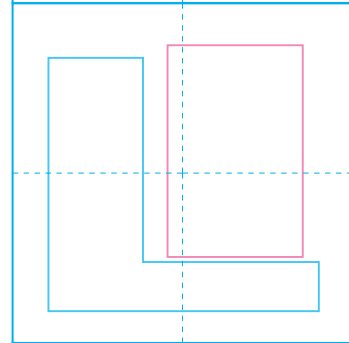
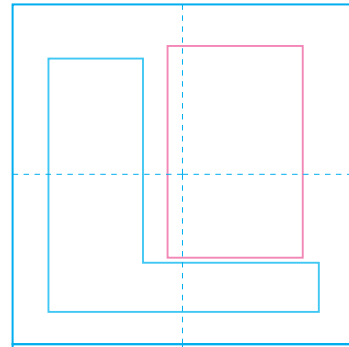

せきが
遠い。
春の
遠足。

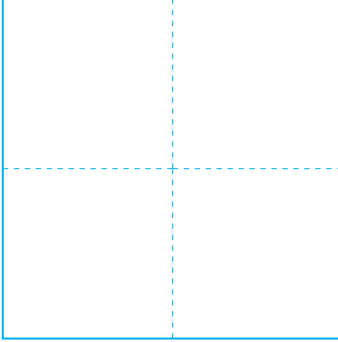
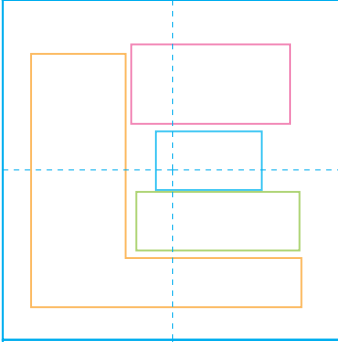
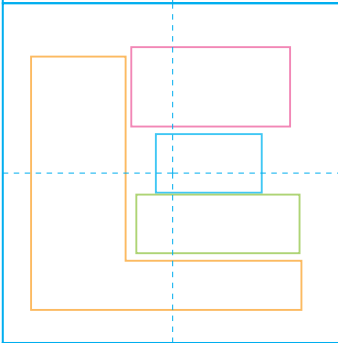
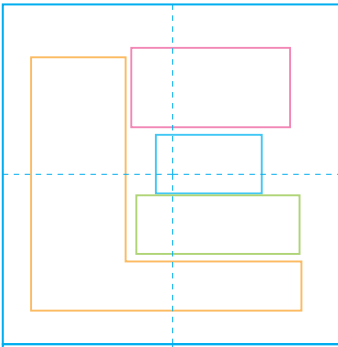

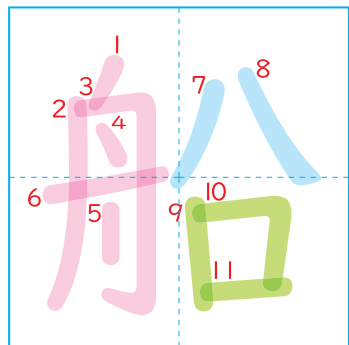

・ 赤^{あか}い
 ・ 船^{ふね}に
 風^{ふう}船^{せん}のる。



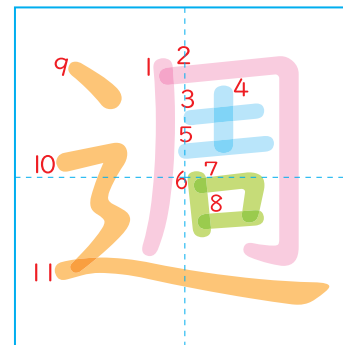

・ 一^{いっしゅう}週^{かん}間のよてい。

月	ちょうれい
火	
水	えんそく
木	
金	
土	うんどうかい
日	



ゆっくり ていねいに、わくの
 中^{なか}に 書^かきましよう。



かん字^じの れんしゅう ⑦③ 「週・船」

なまえ



かん字のれんしゅう⑦④ 「場・市」

なまえ

ゆっくり ていねいに、わくの 中に 書きましょう。

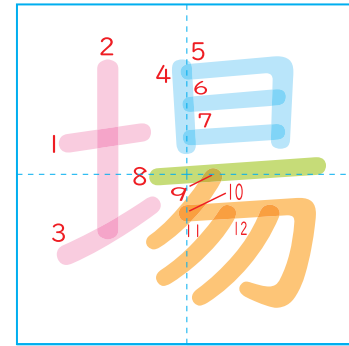

公園のすな場。
工場見学



Handwriting practice grid with four rows. Each row has a pink box on the left and a yellow box on the right, with a dashed midline. The bottom row is empty.

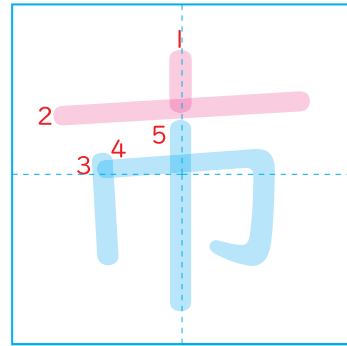

市場の魚。
市長が来る。

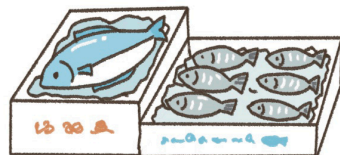

Handwriting practice grid with four rows. Each row has a pink box on the left and a yellow box on the right, with a dashed midline. The bottom row is empty.

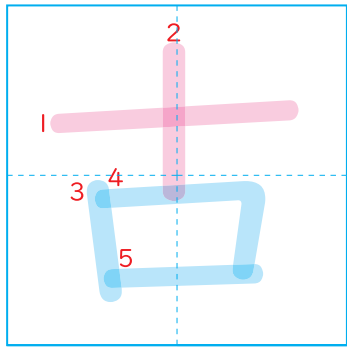

・
古ふる
い

本ほん
。



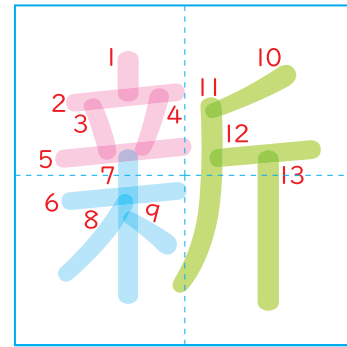

・
新しんねん
年の
あいさつ。

・
新あた
しい
くつ。



ゆっくり
ていねいに、わくの
中なかに
書かきましよう。



かん字じの
れんしゅう ⑦⑤
「新・古」

なまえ

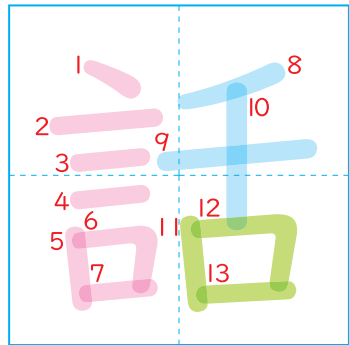

・ おもしろい話。
 ・ 電話で話す。



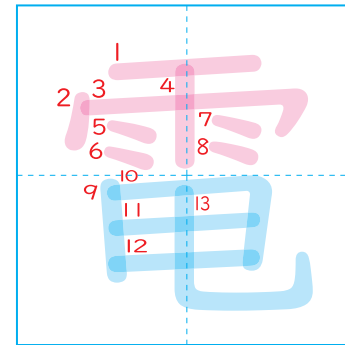

・ 電車にのる。

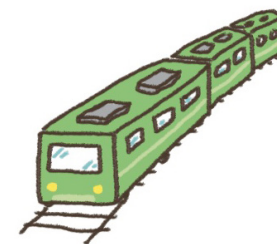









ゆっくり ていねいに、わくの
 中に 書きましょう。



かん字の れんしゅう ⑦⑥ 「電・話」





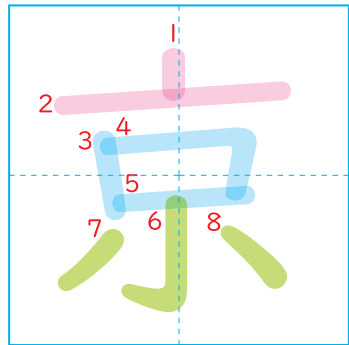



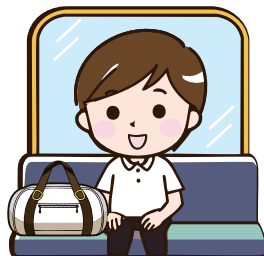

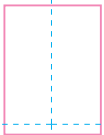
なまえ

		
		
		

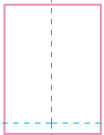

・ 東京とうきょうに行く。

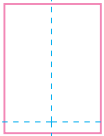

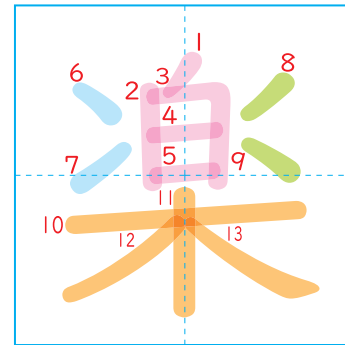

・ 音楽おんがくの時間じかん。
・ 楽たのしい話はなし。



ゆっくりていねいに、わくの中に書きましょう。



かん字じのれんしゅう⑦⑦【楽・京】

なまえ

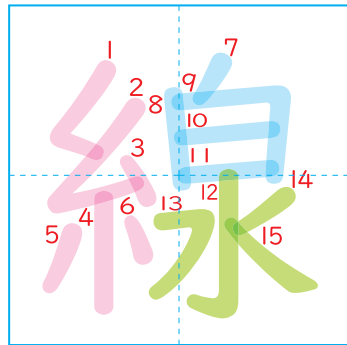

・
線^{せん}
を
引^ひ
く。

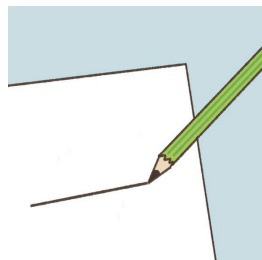

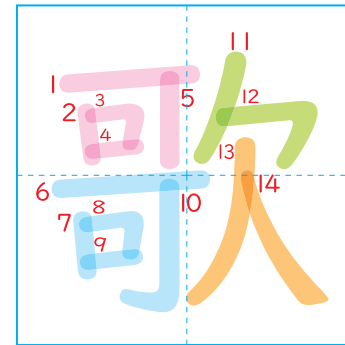

・
校^{こう}
歌^か
を
おぼえる。

・
歌^{うた}
を
歌^{うた}
う。









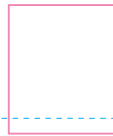

ゆっくり
ていねいに、
わくの
中^{なか}
に
書^か
きましょう。

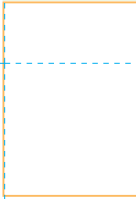

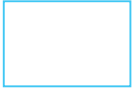
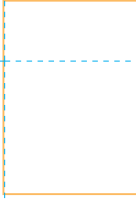
かん字^じ
の
れんしゅう
⑦⑧
「歌・線」



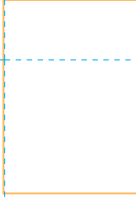

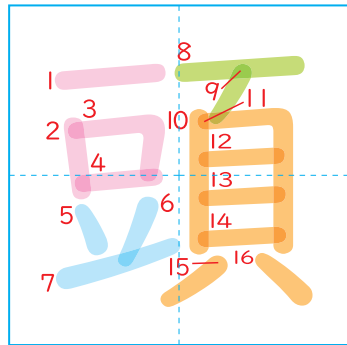



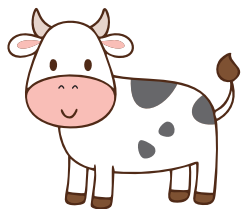

なまえ

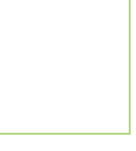

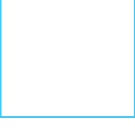

・ 一頭の いっとう
 ・ 頭の あたま
 ・ 牛 うし
 ・ 上 うえ



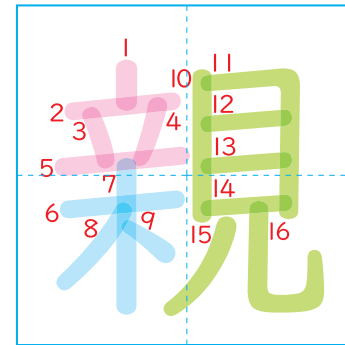

・ 親しい した
 ・ ねこの ねこ
 ・ 人 ひと
 ・ 親子 おやこ

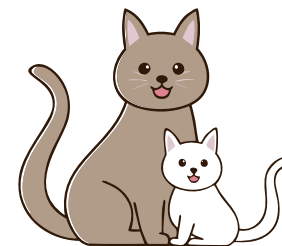

ゆっくり ていねいに、わくの 中 なか に 書 か きましよう。



かん字 じ の れんしゅう ⑦⑨ 「親・頭」

なまえ

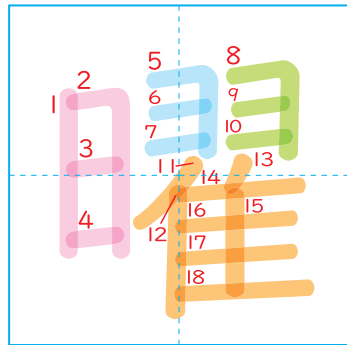

•
日曜日
にちようび

9月

日	月	火	水	木	金	土
					1	2
3	4	5	6	7	8	9
10	11	12	13	14	15	16
17	18	19	20	21	22	23
24	25	26	27	28	29	30

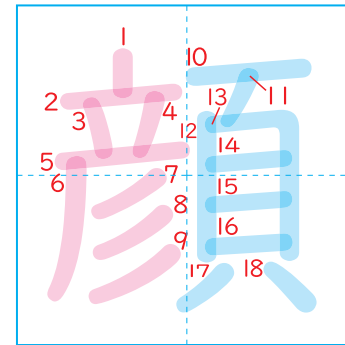

•
顔をあらう。
かおを



ゆっくり ていねいに、わくの
中に
書きましょう。



かん字の
れんしゅう⑧
「顔・曜」

なまえ