

もくじ

やさしい文字順です。

た	せ	け	か	も	き	さ	ら	ち	ろ	ひ	の	に	と	り	う	こ	い	し	へ	つ	て	く
(高尾)	(千駄ヶ谷)	(池袋)	(神田)	(本八幡)	(北千住)	(笹塚)	(浦和)	(千葉)	(六本木)	(日比谷)	(乃木坂)	(日暮里)	(東京)	(両国)	(上野)	(高円寺)	(飯田橋)	(品川)	(平和島)	(築地)	(天王洲アイル)	(国立)
.....
23	22	21	20	19	18	17	16	15	14	13	12	11	10	9	8	7	6	5	4	3	2	1
を	あ	や	ふ	れ	わ	ゆ	め	る	ぬ	ね	む	み	よ	ほ	は	な	お	ま	す	ん	え	そ
(電車をみる)	(秋葉原)	(四ツ谷)	(府中)	(東京テレポート)	(早稲田)	(有楽町)	(目黒)	(東久留米)	(沼袋)	(根津)	(武蔵境)	(三鷹)	(代々木)	(保谷)	(原宿)	(中野)	(大塚)	(町田)	(巣鴨)	(新宿)	(恵比寿)	(蘇我)
.....
46	45	44	43	42	41	40	39	38	37	36	35	34	33	32	31	30	29	28	27	26	25	24

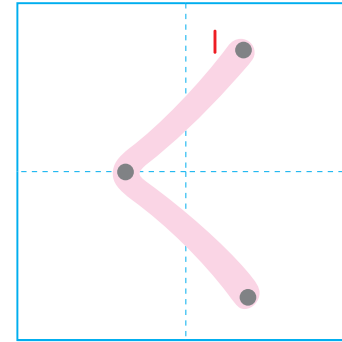

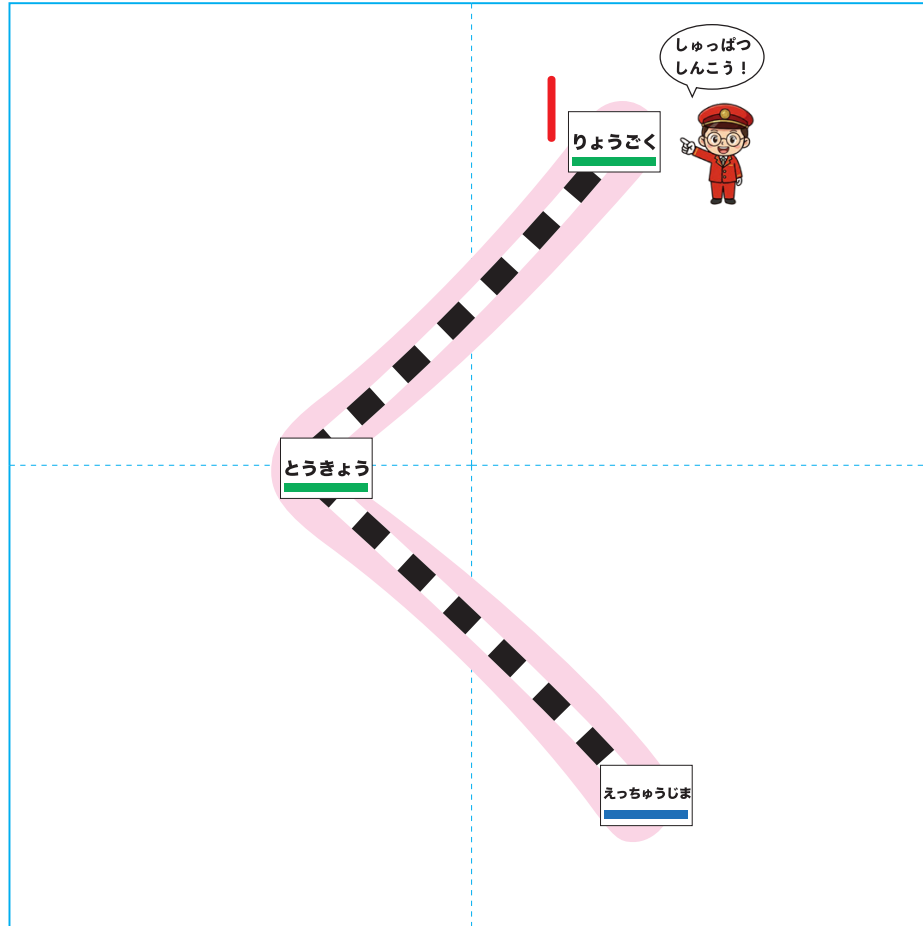
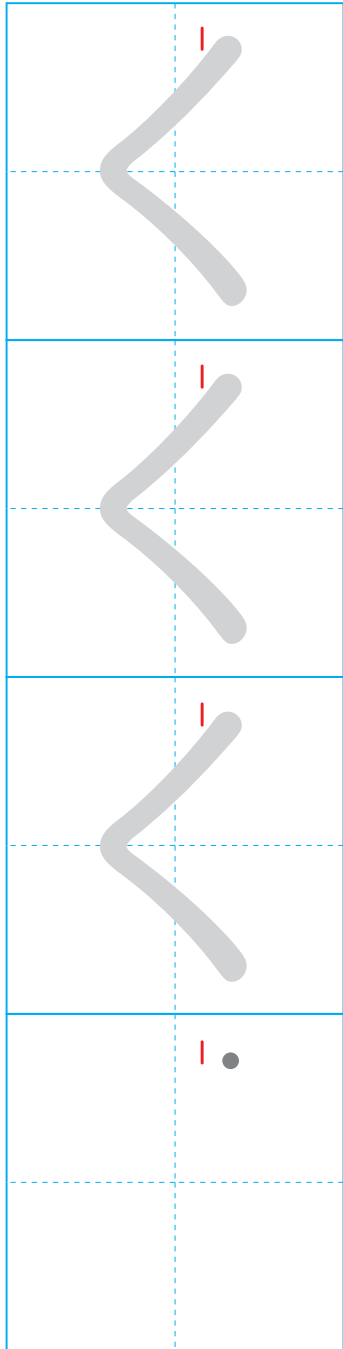

くにたち



なまえ



なまえ

てんのうずアイル

天王洲アイル

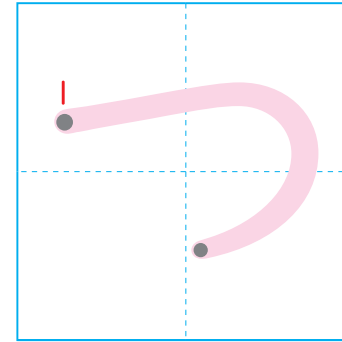
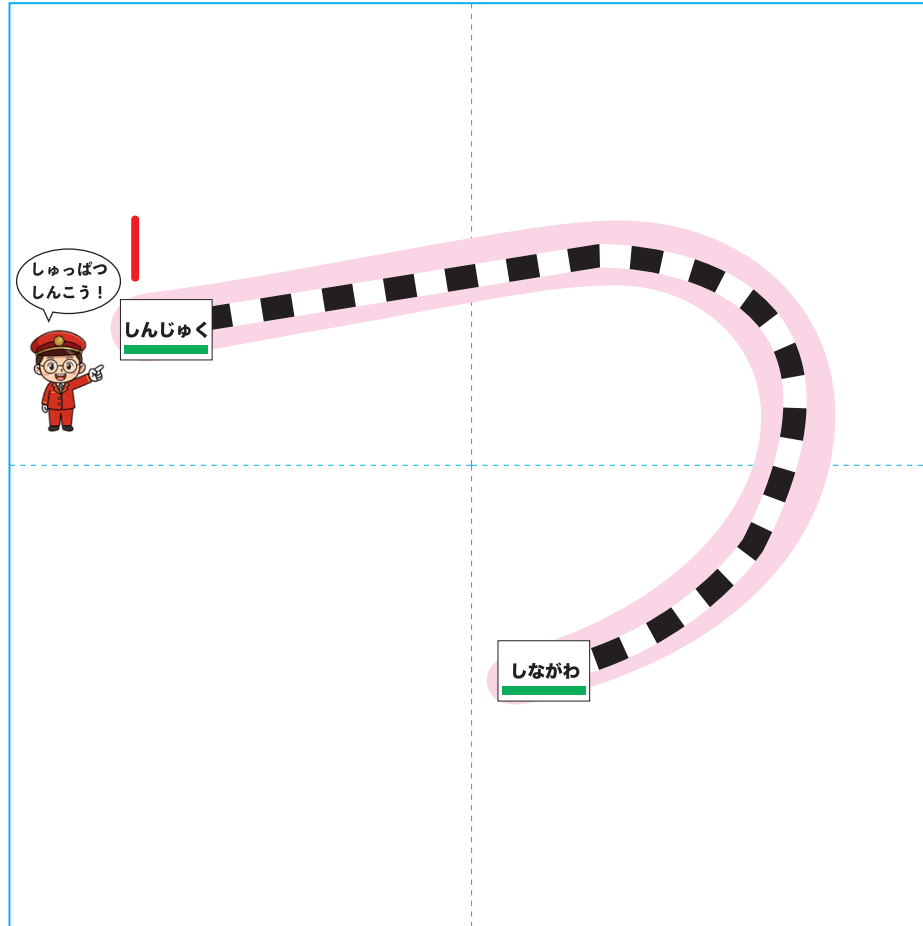
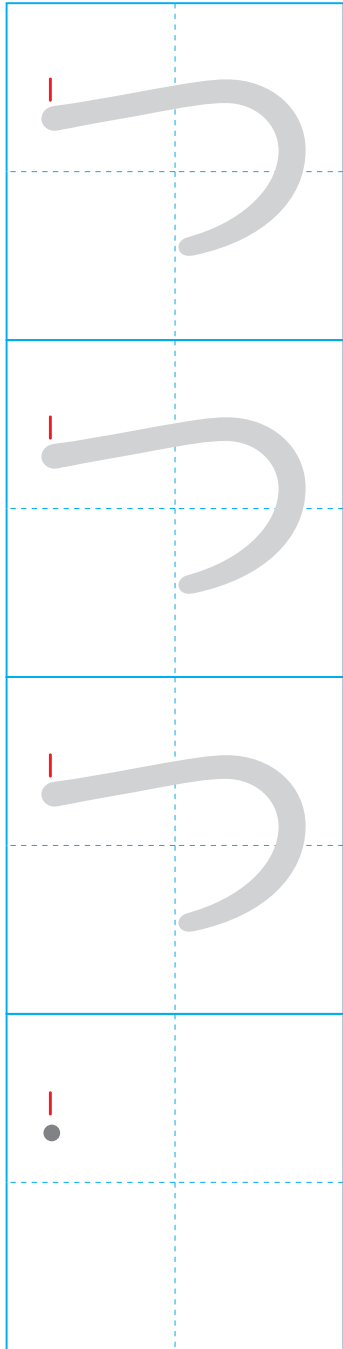

しきじ

築地



なまえ

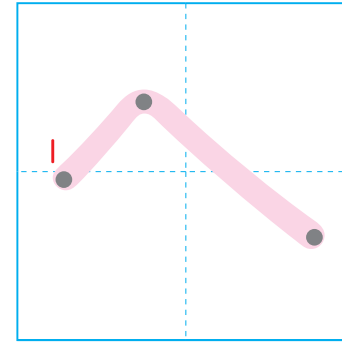
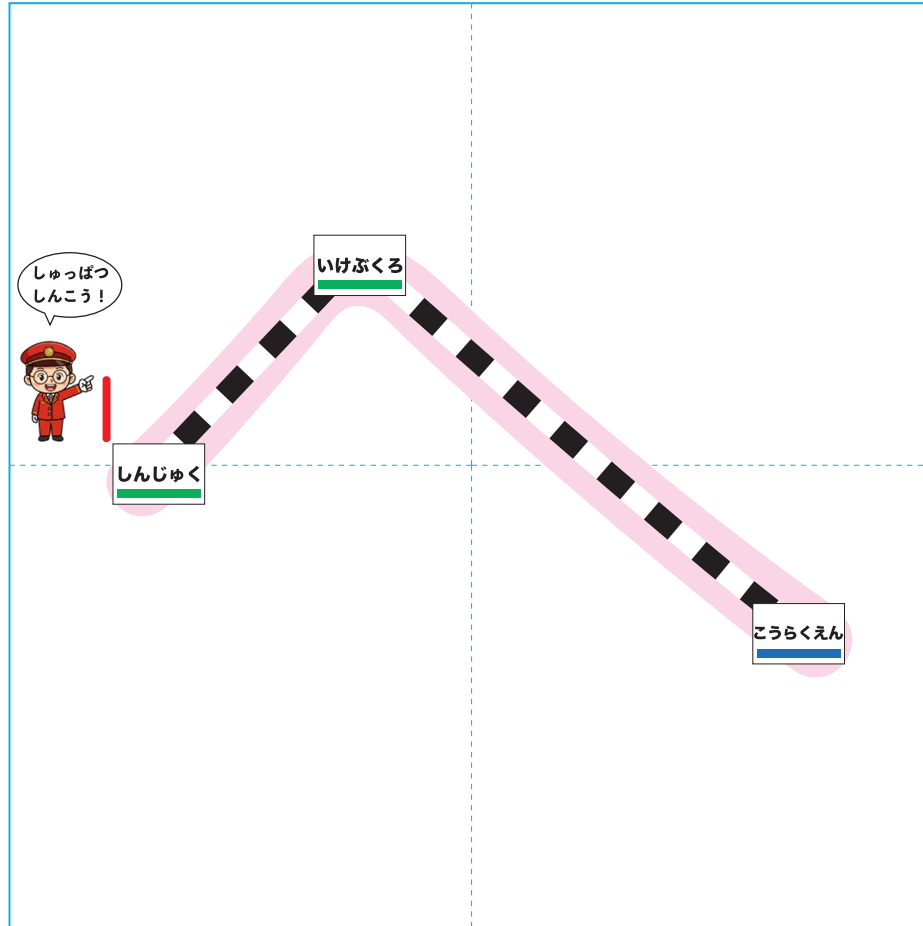
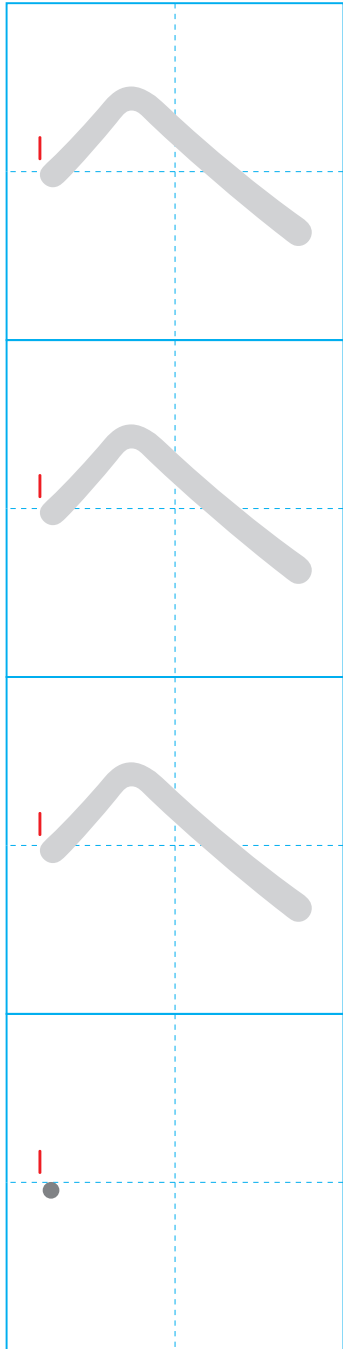

人
い
わ
じ
ま

平和島



なまえ

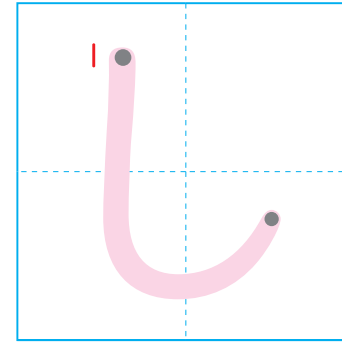
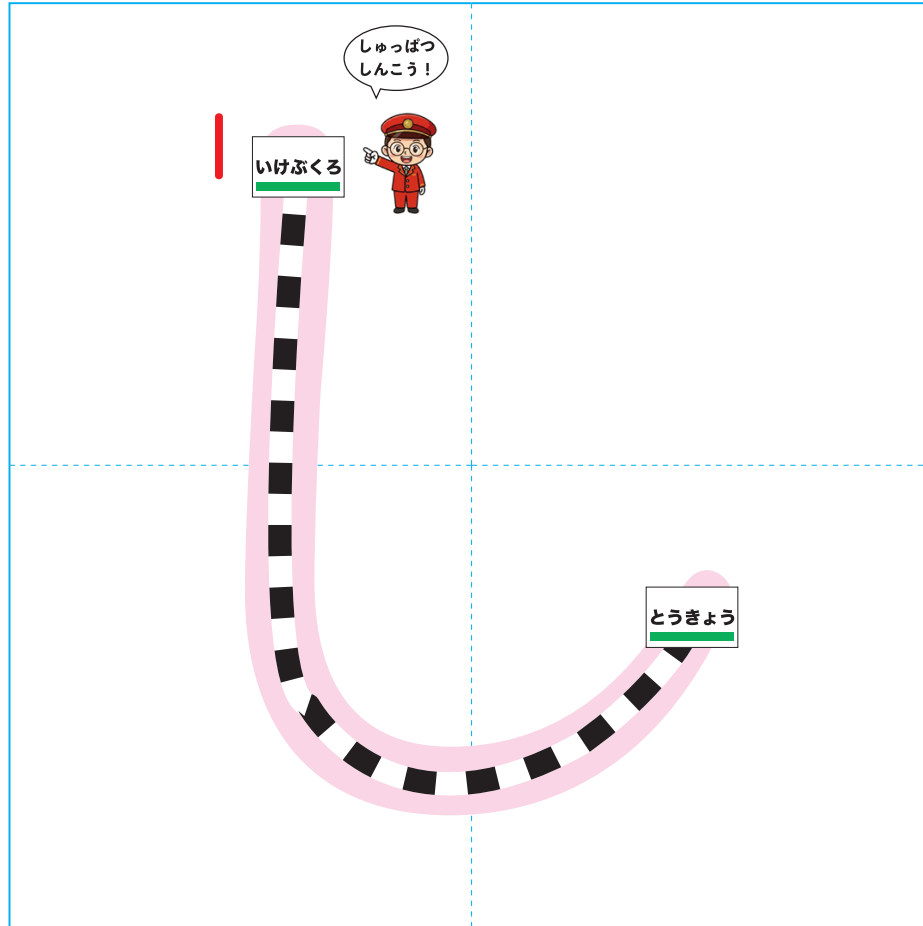
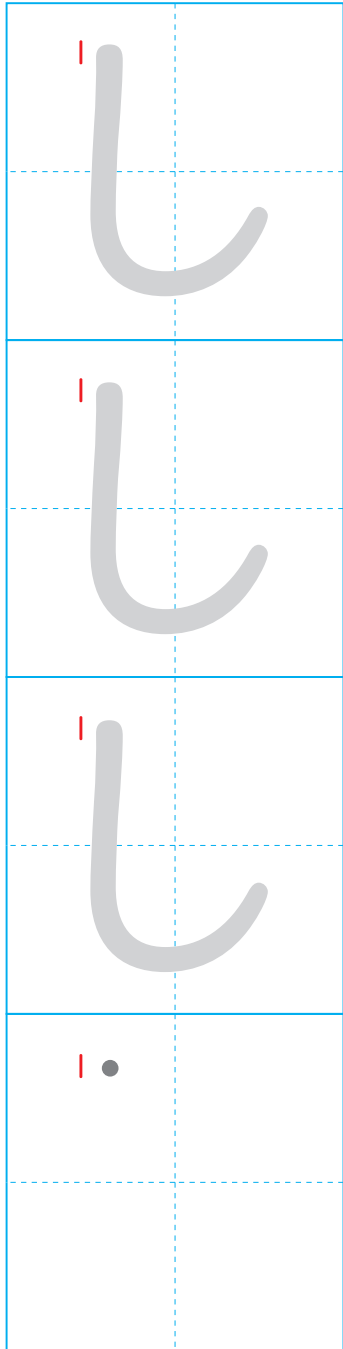

し
な
が
わ



なまえ

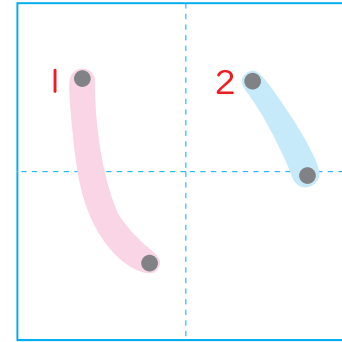
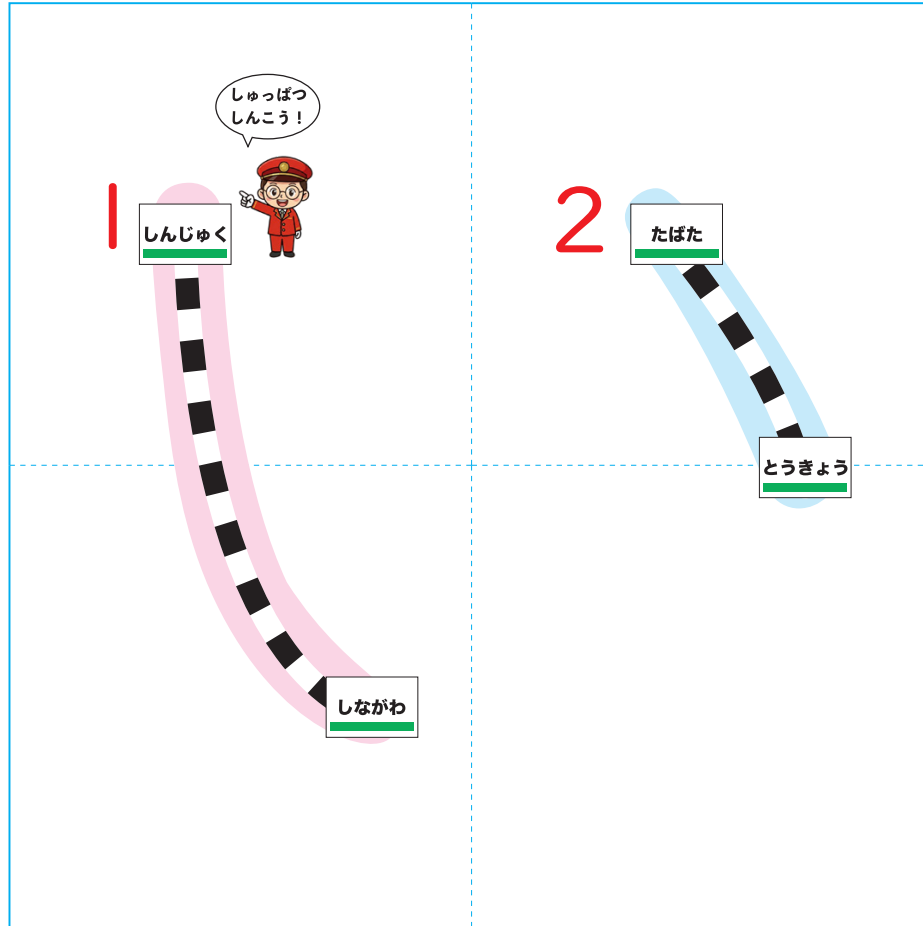
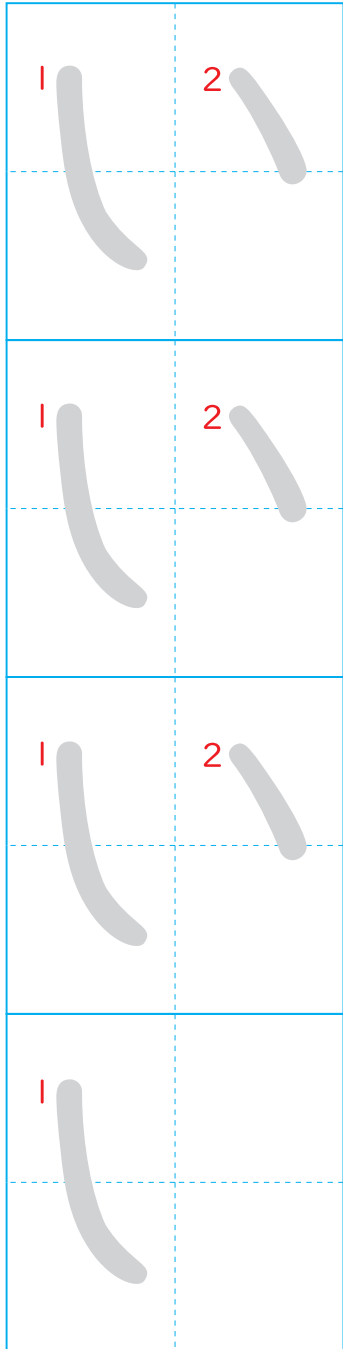

なまえ

い
い
だ
ば
し

飯田橋

Handwriting practice for the Japanese character 'う' (u). The page is divided into four rows, each with a vertical dashed line and a horizontal dashed line. The first three rows show the character 'う' with stroke order numbers 1 and 2. The first row shows the character in grey. The second and third rows show the character in light blue. The fourth row shows only the first stroke (a short horizontal line) in grey, with the rest of the row blank for practice.

Illustration of a train track with a station attendant. The attendant is a cartoon character in a red uniform and cap, saying "しゅっぱつ しんこう!" (Shuppan Shinkou!). The train track is a blue curve with black and white checkered patterns. Labels in boxes point to different parts of the track: "あかぼね" (Akabone) and "おうじ" (Ouji) at the top right, "いけぶくろ" (Ikebukuro) at the top left, and "しながわ" (Shinagawa) at the bottom. A large red number '2' is placed near the top left of the track curve.

Handwriting practice for the Japanese character 'う' (u). The character is shown in light blue with stroke order numbers 1 and 2. Stroke 1 is a short horizontal line, and stroke 2 is a curved line that starts below stroke 1 and curves downwards and to the right.



なまえ

う
え
の

上 野

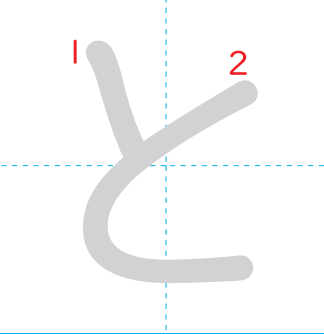
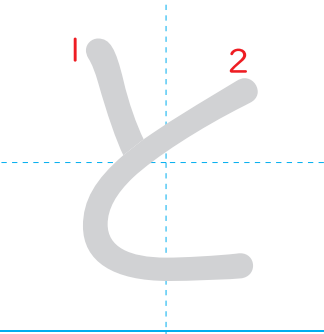
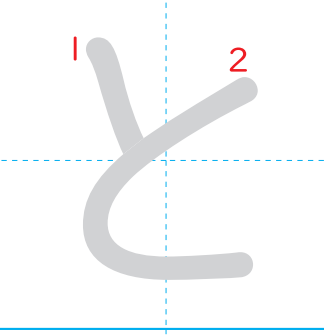
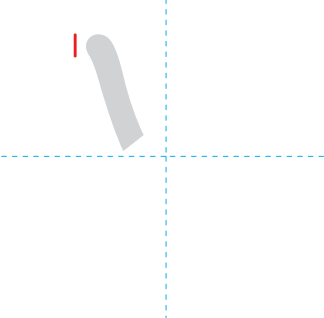
なまえ

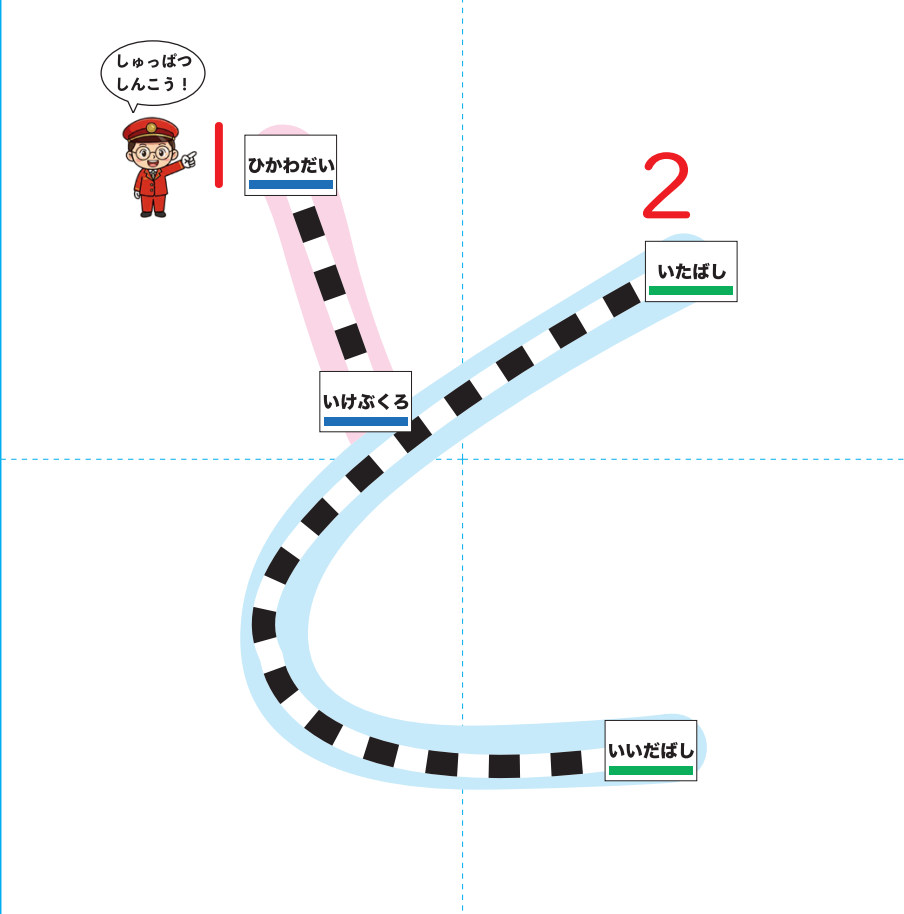
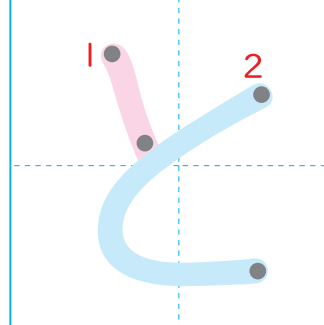
と
う
き
よ
う

東京

1	2	3
1	2	3
1	2	3
1		

しゅっぱつ
しんこう!

いけぶくる

2

すかも

にっぽり

3

しながわ

しんぼし

しぶや

1	2
3	



なまえ

に
っ
ぽり

日暮里

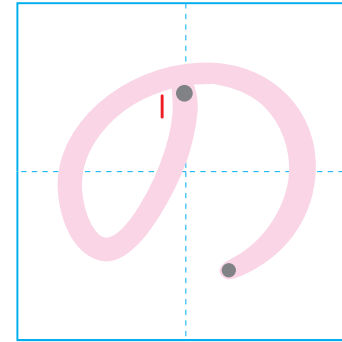
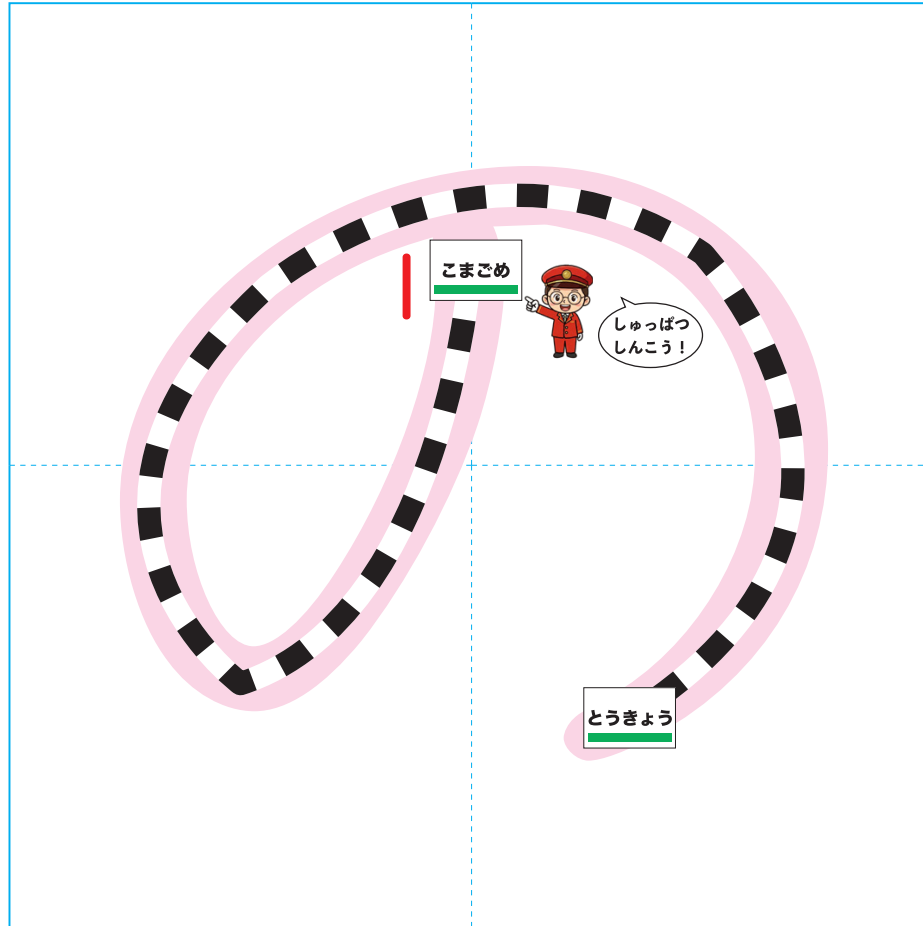
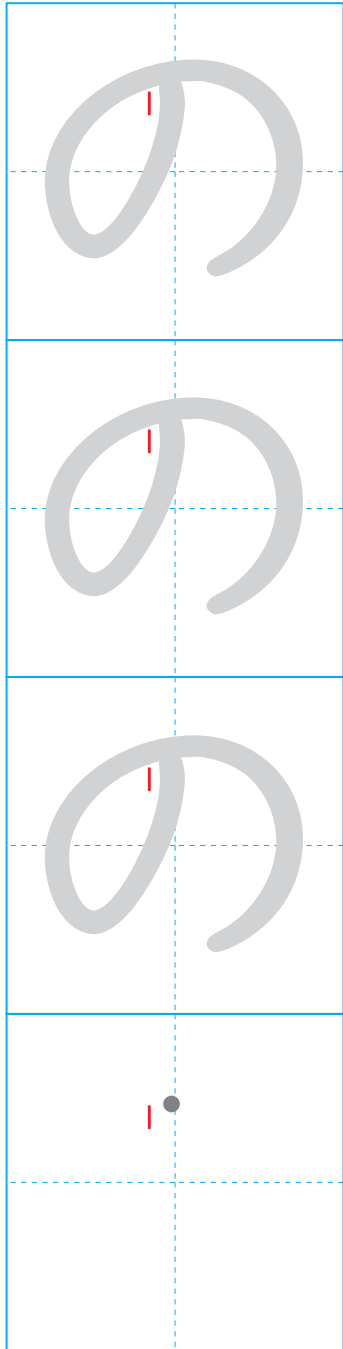

のぎぎが

乃木坂



なまえ

ひ	
ひ	
ひ	
●	

ひ
び
や



なまえ

日比谷

ろ

ろ

ろ

ろ

ろ

しゅっぱつ
しんこう!

とだ

あかばね

いけぶくろ

しながわ

ろ

っ

ぽ

ん

ぎ

六本木



なまえ

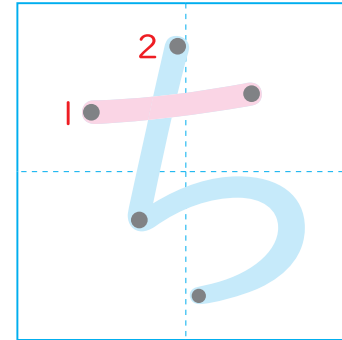
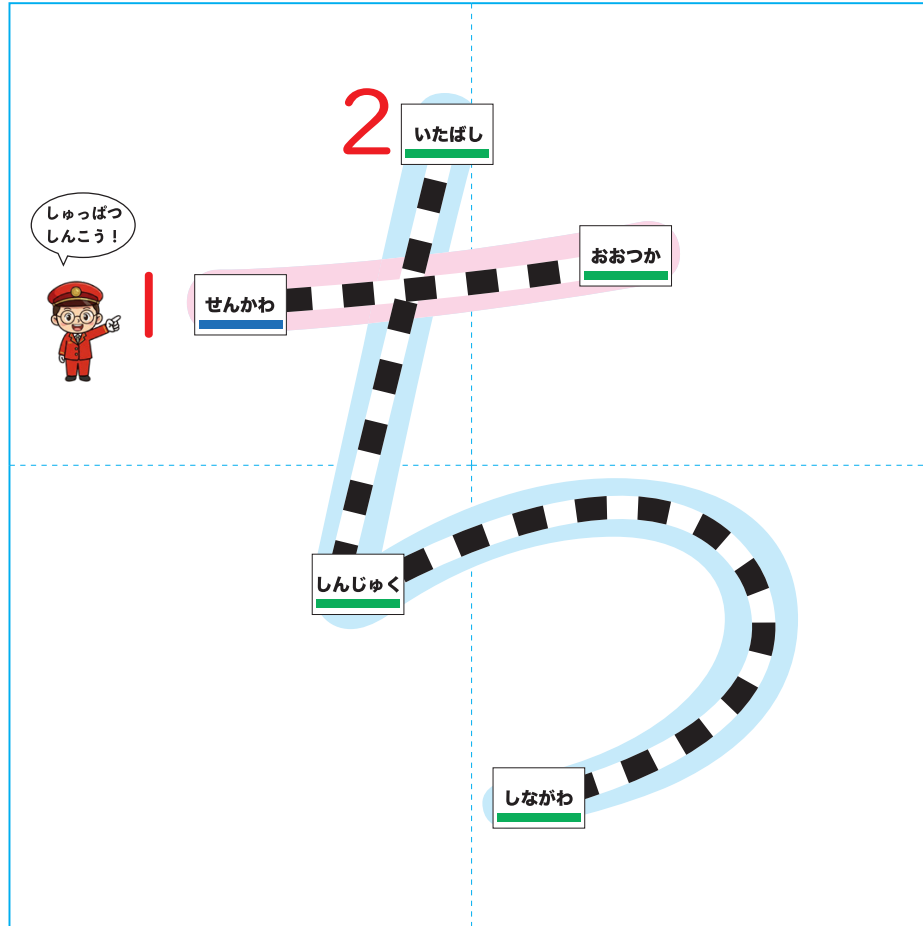
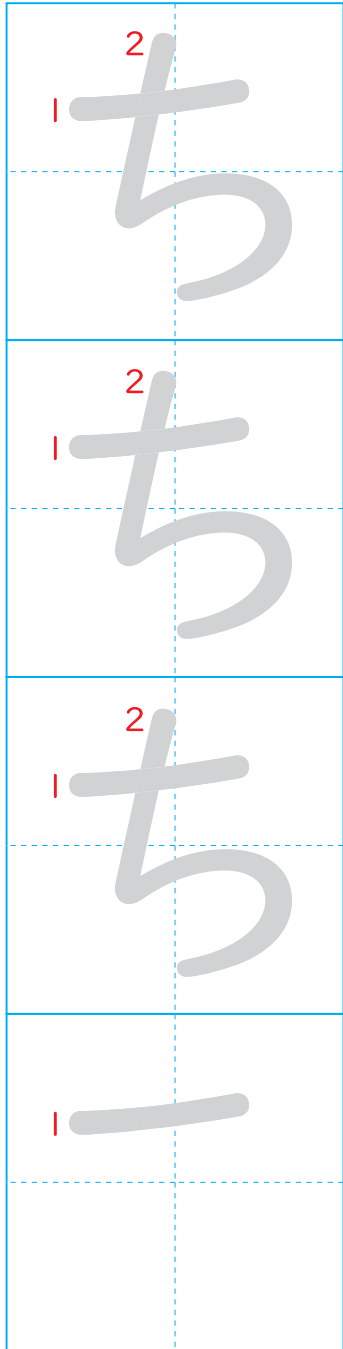

ち
ば



なまえ

千葉

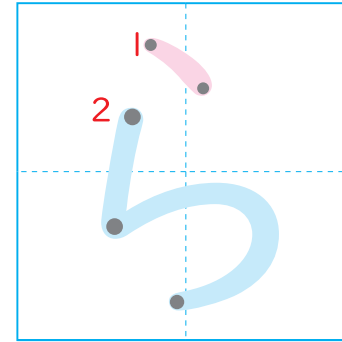
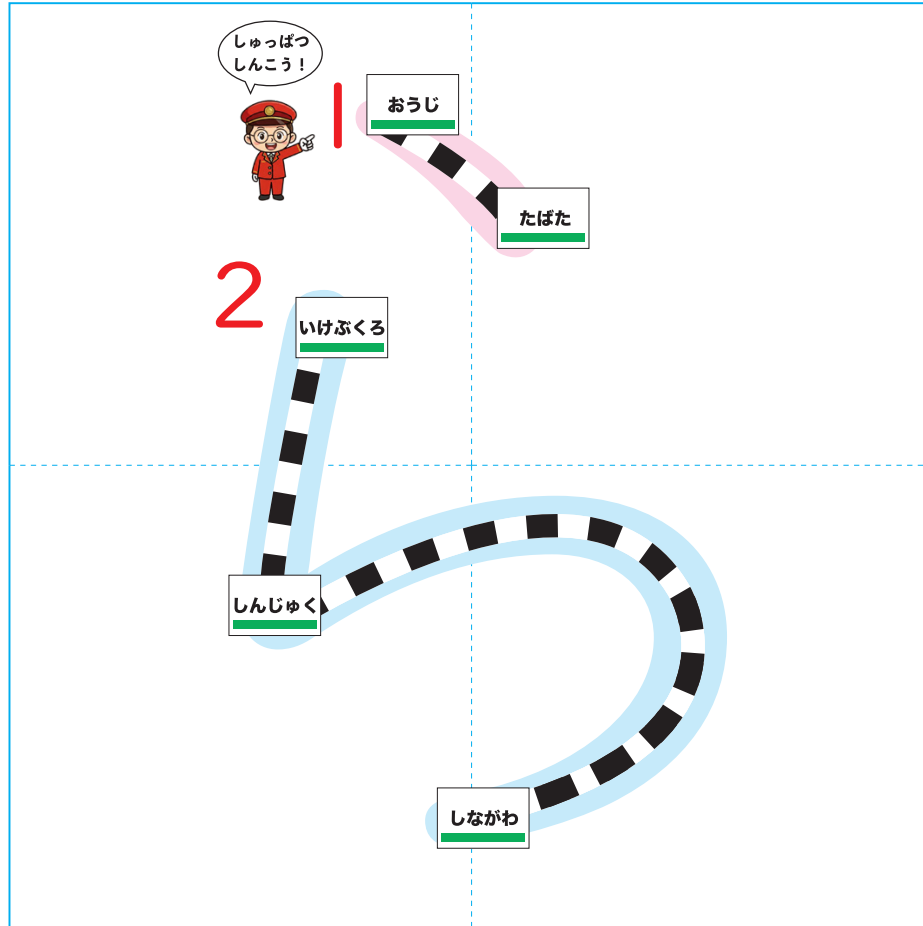
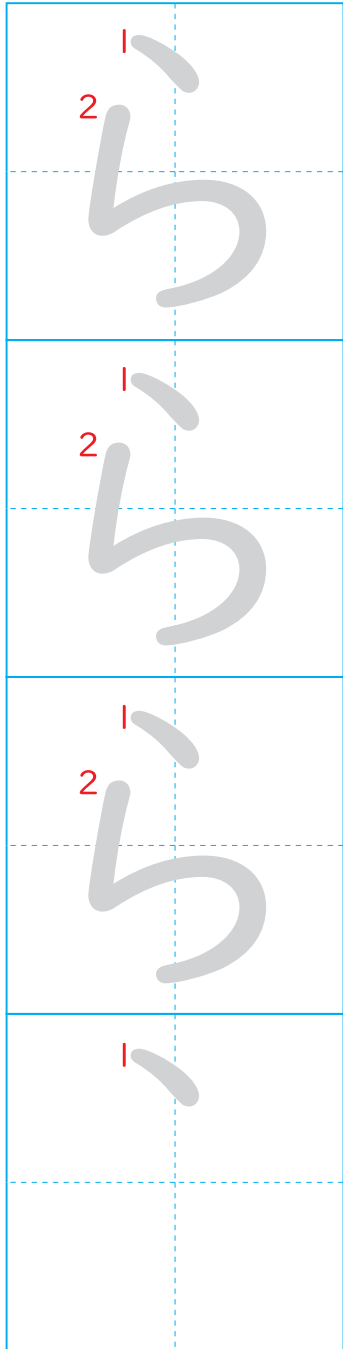

う
ら
わ



なまえ

浦 和

Handwriting practice grid for the character 'ナ' (Na). It consists of five rows, each with a dashed vertical line and a dashed horizontal line. The first four rows show the stroke order for writing 'ナ':

- Row 1: Stroke 1 (vertical line down), Stroke 2 (horizontal line across), Stroke 3 (diagonal line down-right).
- Row 2: Stroke 1 (vertical line down), Stroke 2 (horizontal line across), Stroke 3 (diagonal line down-right).
- Row 3: Stroke 1 (vertical line down), Stroke 2 (horizontal line across), Stroke 3 (diagonal line down-right).
- Row 4: Stroke 1 (vertical line down), Stroke 2 (horizontal line across), Stroke 3 (diagonal line down-right).

The fifth row shows only the first stroke (vertical line down) for practice.

Illustration of a train crossing the character 'ナ' (Na). The character is drawn with a pink horizontal bar, a blue diagonal bar, and a green curved bar. A train with black and white checkered tracks crosses it. A train conductor character is on the left, saying "しゅっぱつ しんこう!". Labels for train stations are placed along the tracks:

- かすが (Kasuga) at the top of the blue diagonal track.
- あきはばら (Akihabara) at the right end of the pink horizontal track.
- おおてまち (Ootemachi) at the bottom of the blue diagonal track.
- いいだばし (Iidabashi) at the left end of the pink horizontal track.
- しふや (Shiwaya) at the top of the green curved track.
- しながわ (Shinagawa) at the right end of the green curved track.

Handwriting practice for the character 'ナ' (Na) with stroke order indicators:

- Stroke 1: Vertical line down (pink).
- Stroke 2: Horizontal line across (blue).
- Stroke 3: Diagonal line down-right (green).



なまえ

ナ
ナ
ナ
ナ
か

なまえ

笹塚

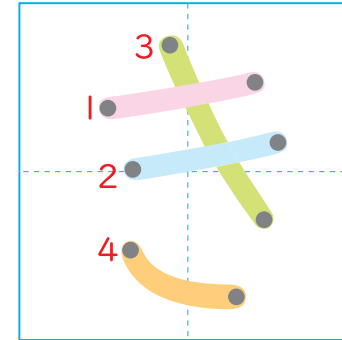
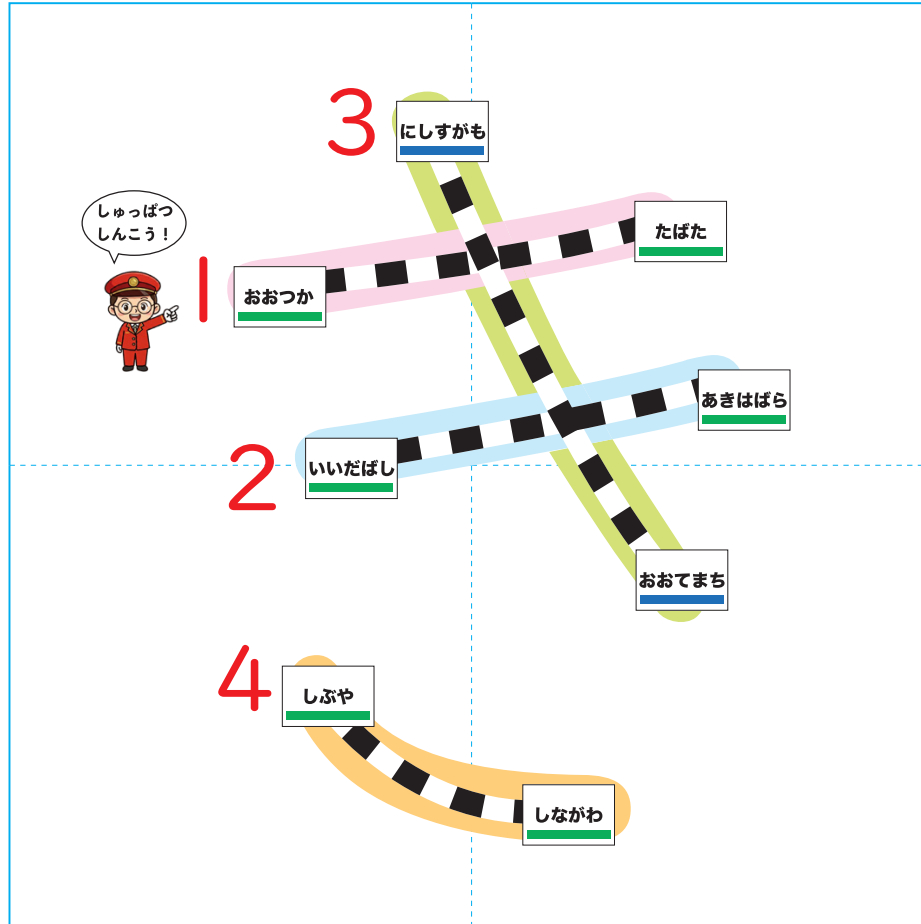
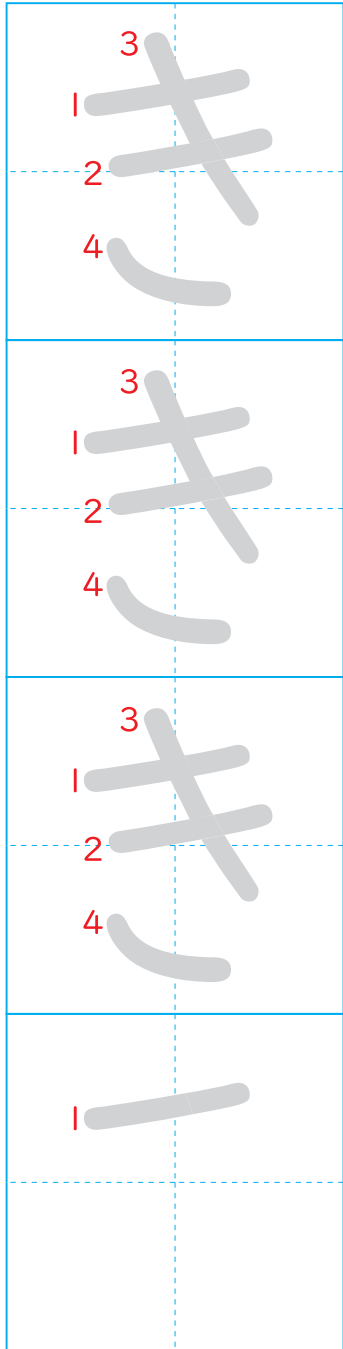

なまえ

きたせんじゆ

北千住

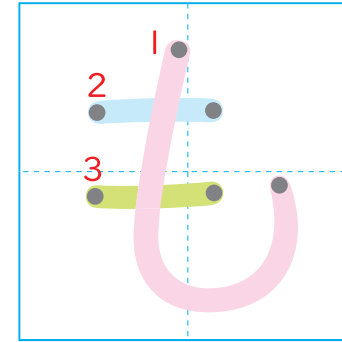
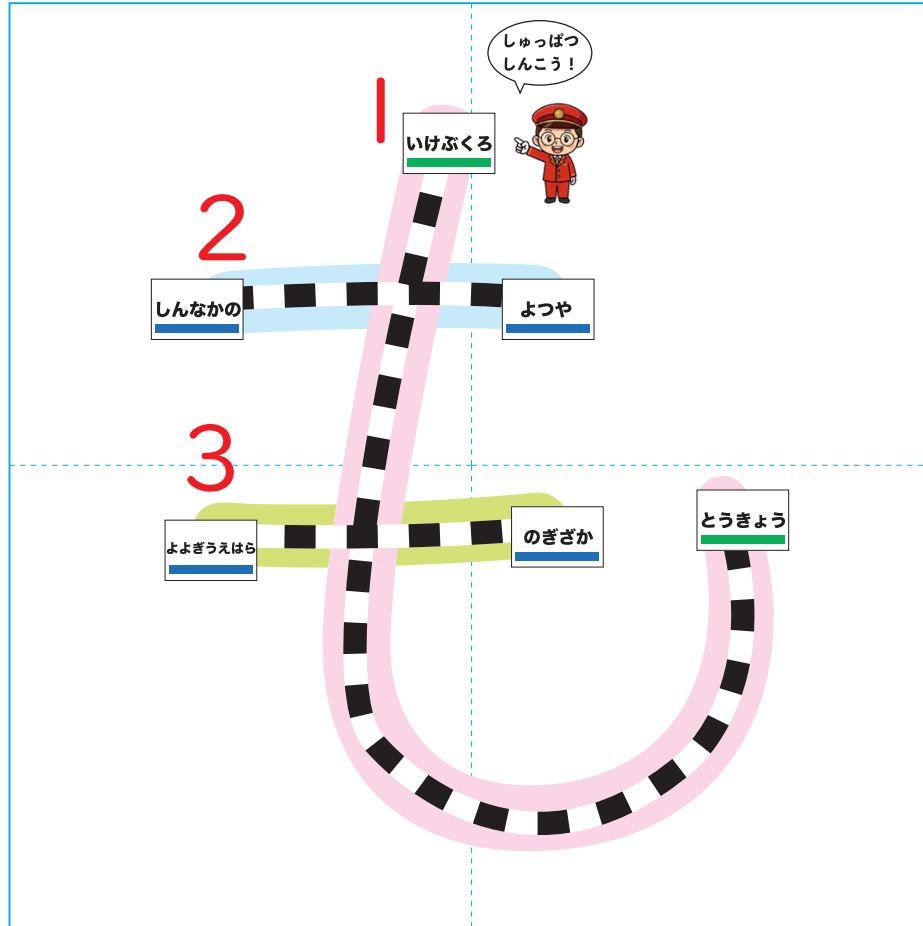
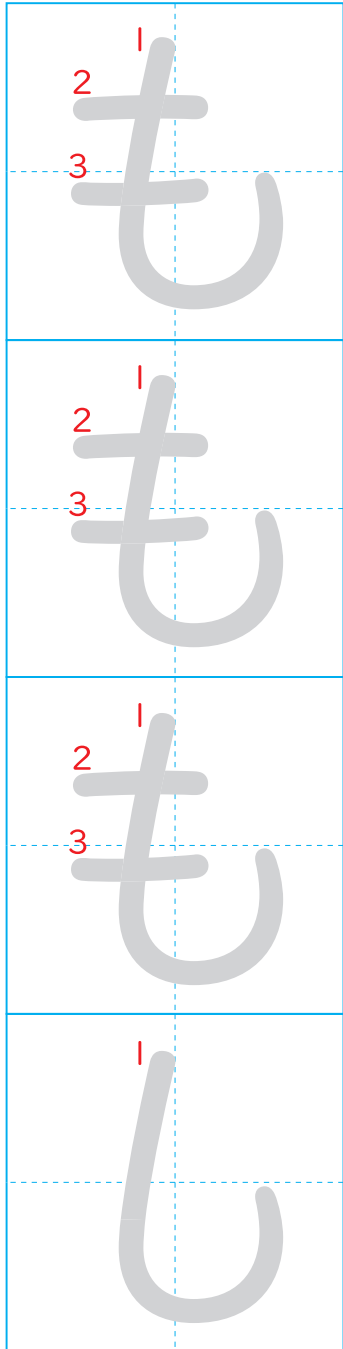

も
と
や
わ
た

本八幡



なまえ

か

か

か

か

しゅっぱつ
しんこう!

かすが

うえの

とうきょう

かちどき

いしかわ

にしふなばし

か

か
ん
だ



なまえ

神 田

1 2 3
け

1 2 3
け

1 2 3
け

1
し

しゅっぱつ
しんこう!

1 いけぶくる

2 すいどうばし

3 うえの

りょうさく

えびす

しながわ

1 2 3



なまえ

い
け
ぶ
く
ろ

池 袋

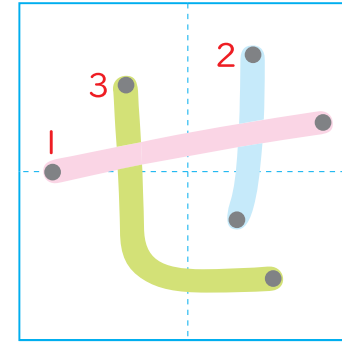
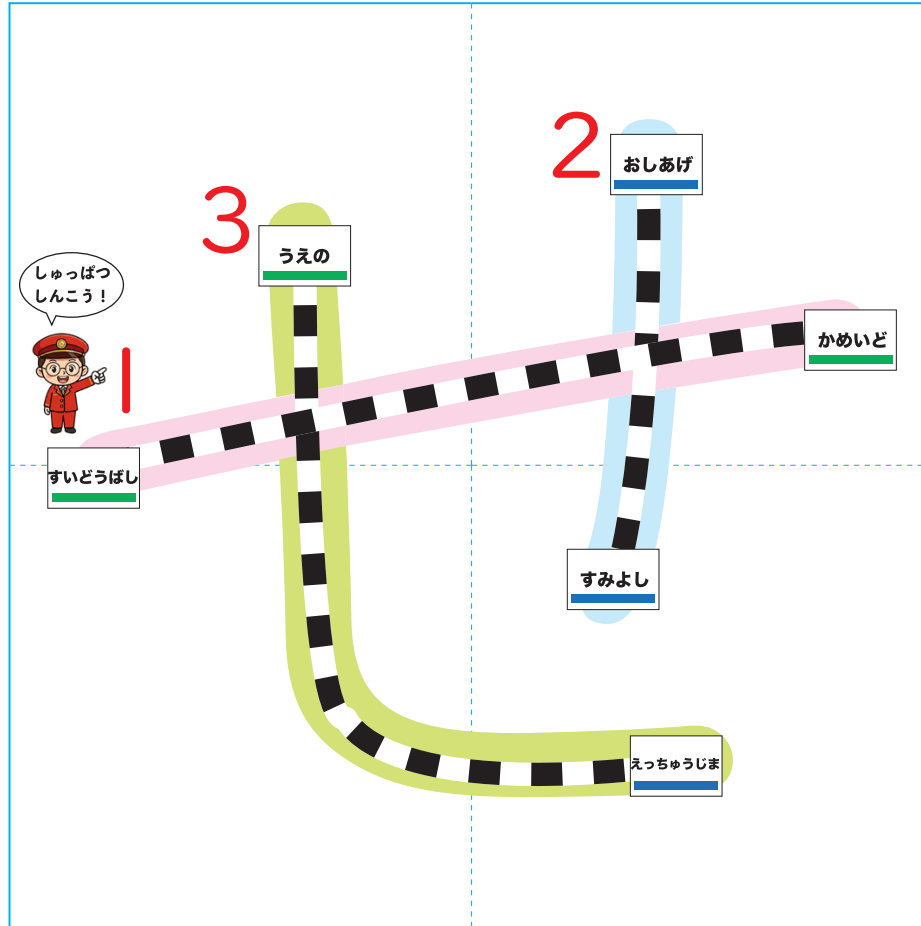
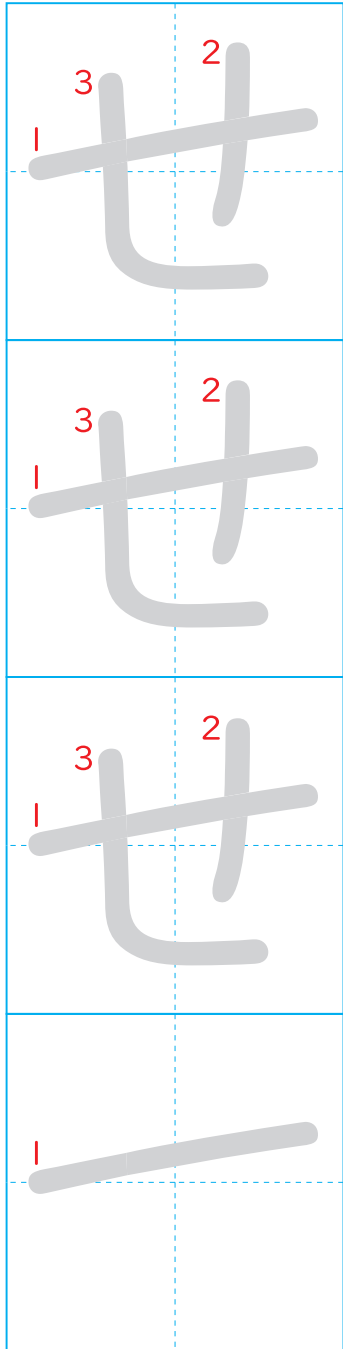

なまえ

せ
ん
だ
が
や

千駄ヶ谷

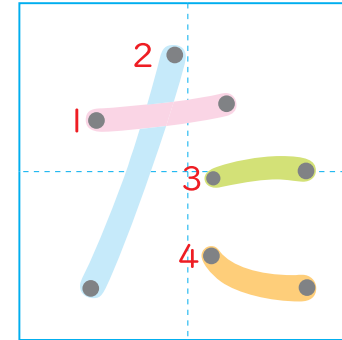
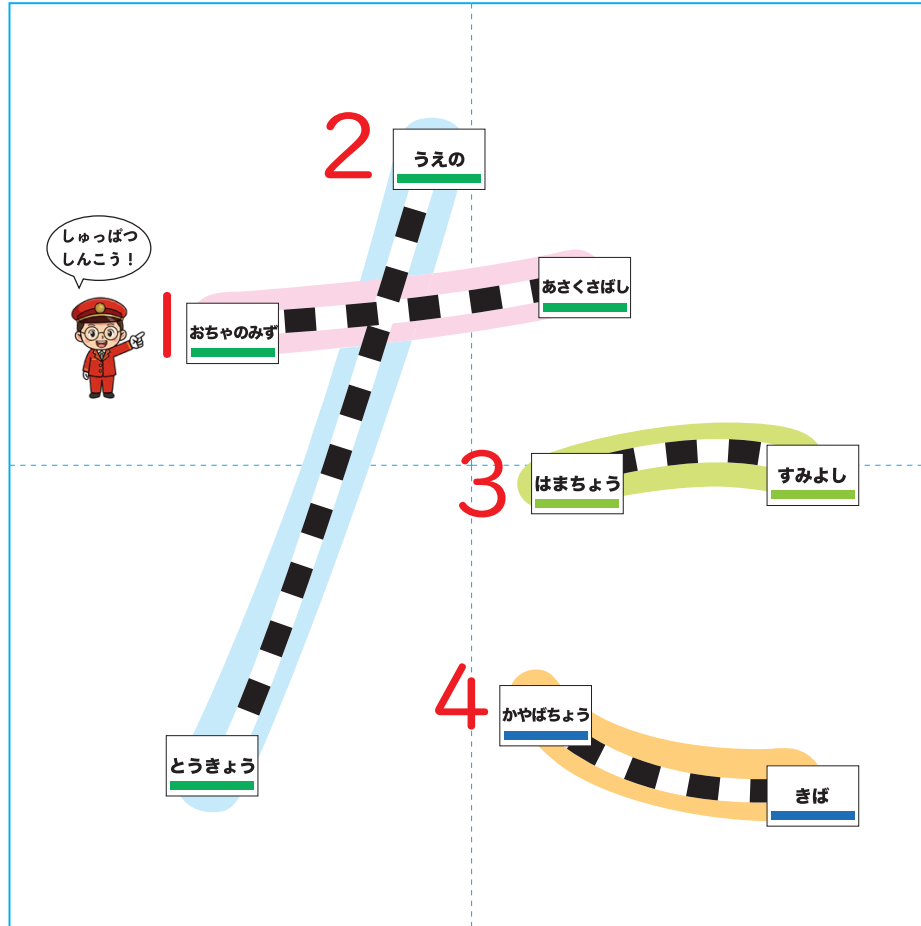
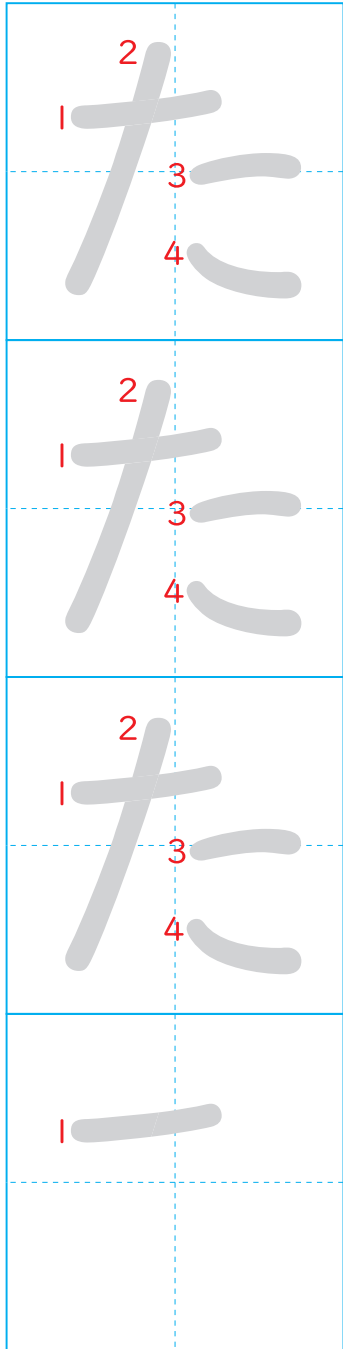

なまえ

た
か
お

高尾

そ

そ

そ

●

しゅっぱつ
しんこう!

せんかわ

いけぶくろ

しんじゆく

いいだぼし

ぎんざ

そ

そ
が

蘇 我



なまえ

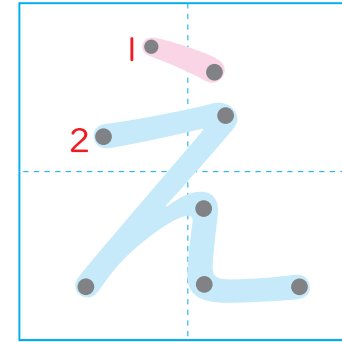
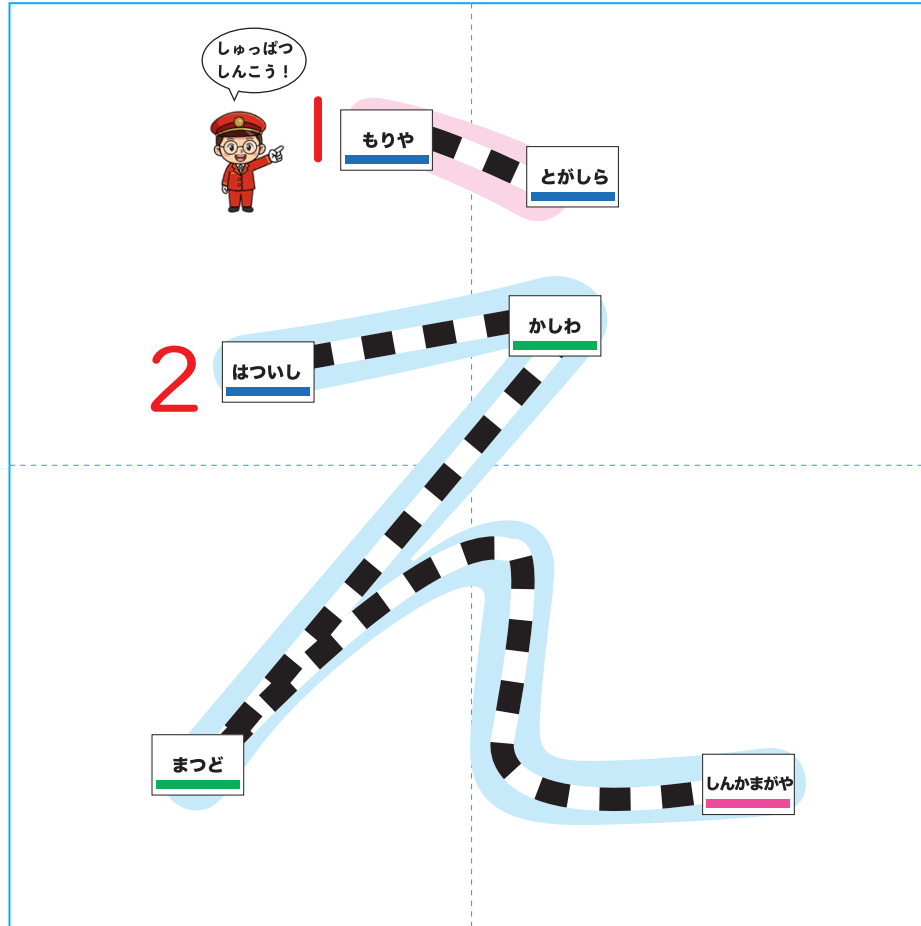
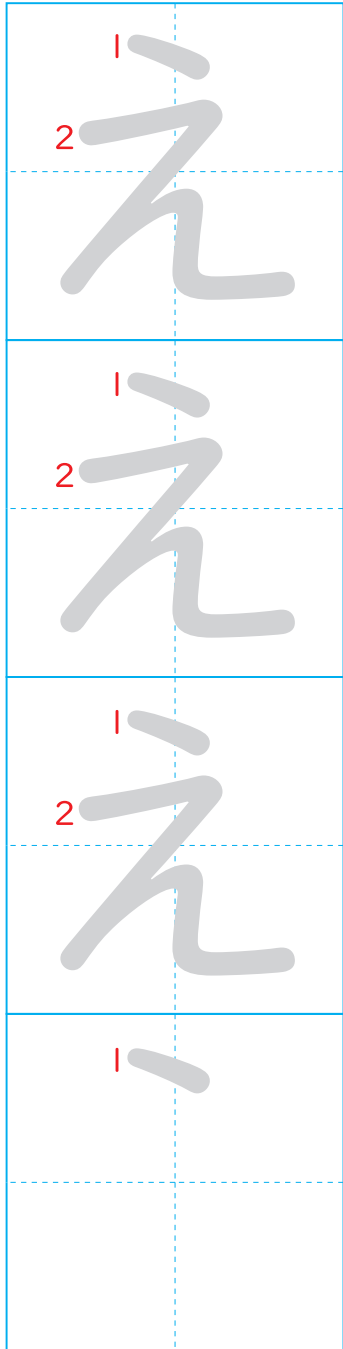

なまえ

え
び
す

恵比寿

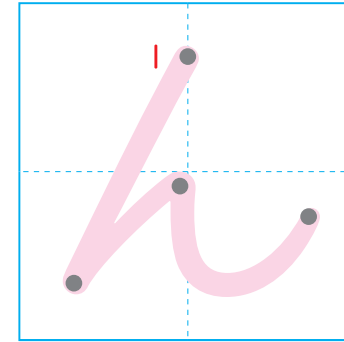
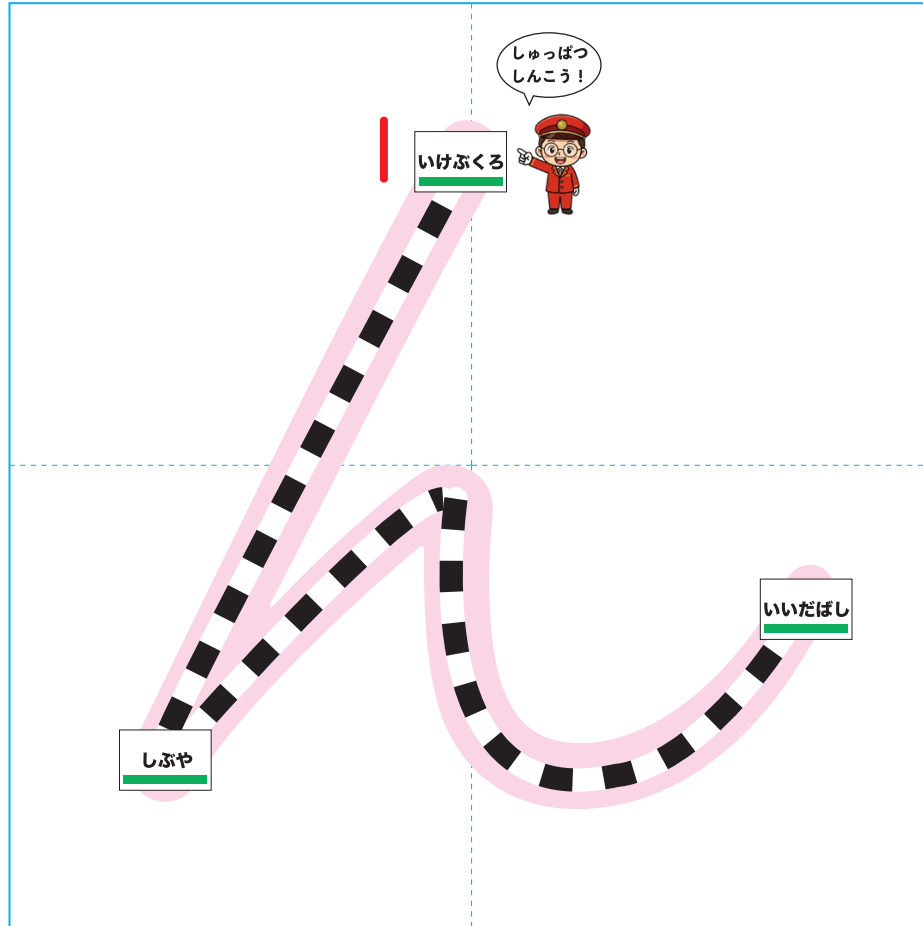
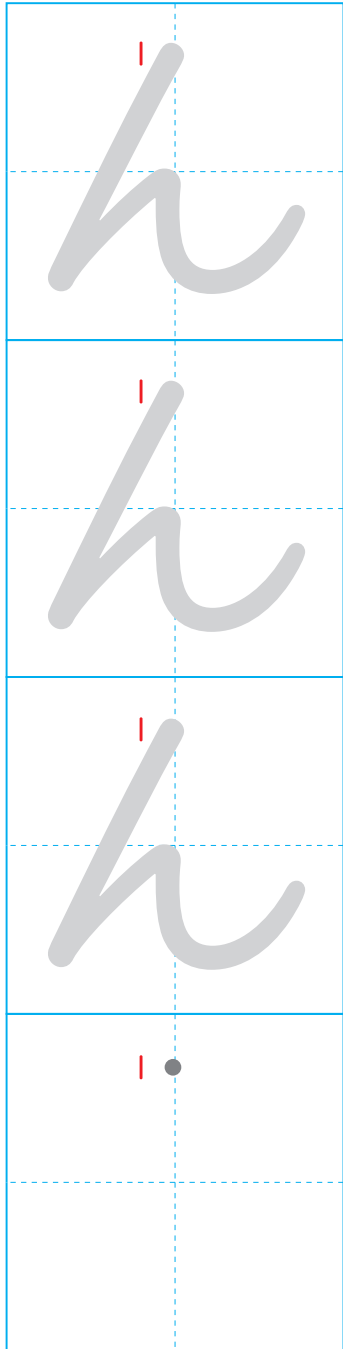

なまえ

し
ん
じ
ゆ
く

新 宿

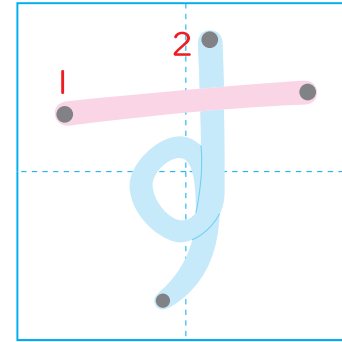
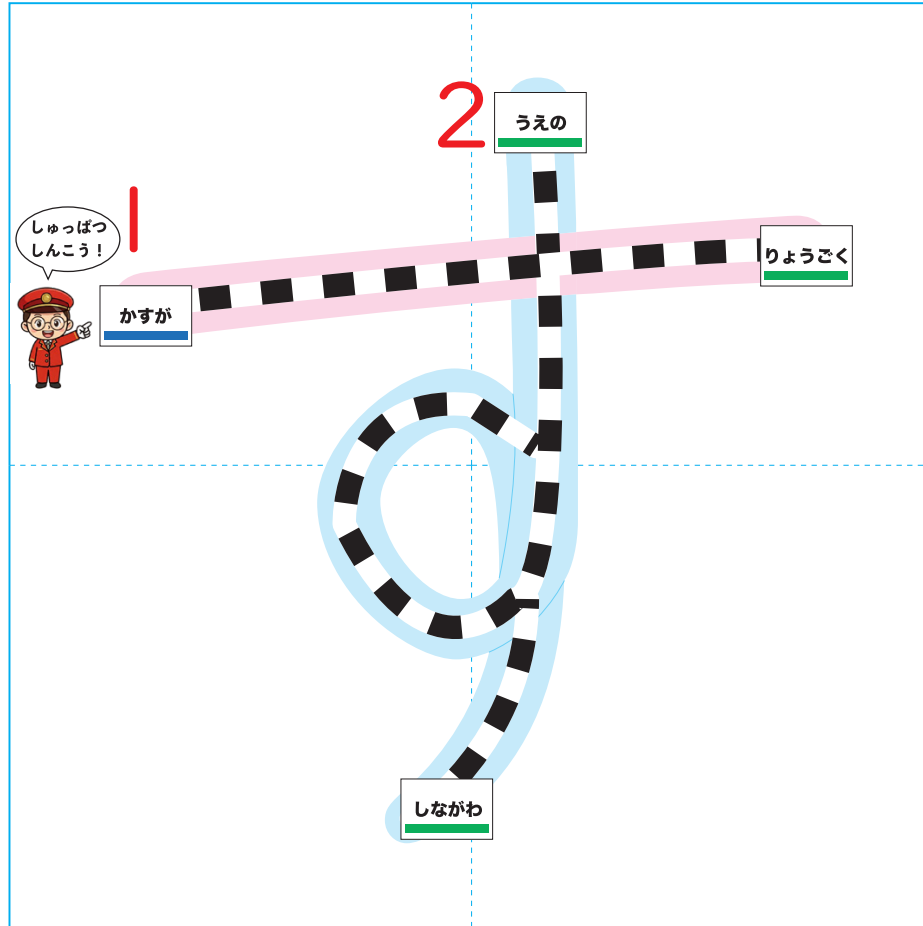
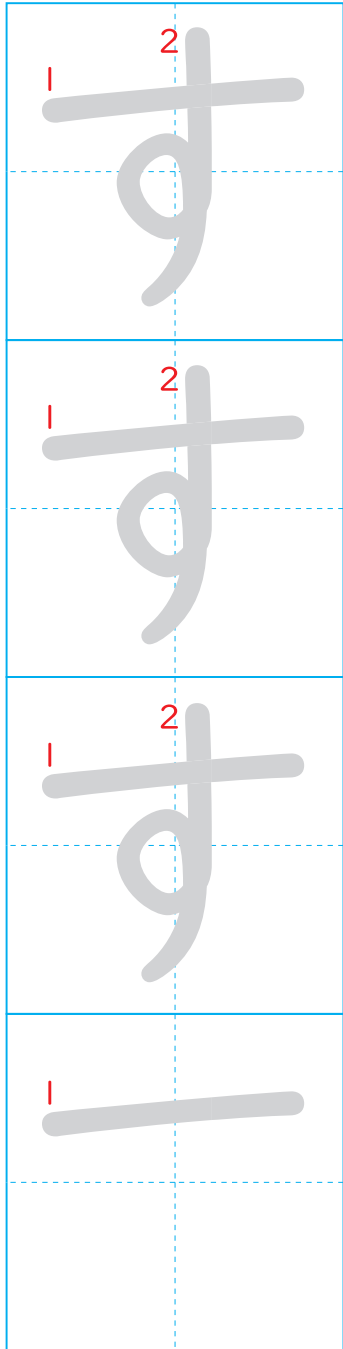

す
が
も



なまえ

1 3
2

1 3
2

1 3
2

1

1 しゅっぱつ
しんこう!

かなめちよう

いたばし

ひがし
いけぶくろ

2 なかい

わせだ

3 よつや

1 3
2



なまえ

ま
ち
だ

町 田

Handwriting practice for the character 'お' (o). The first three rows show the character with stroke order numbers 1, 2, and 3. The fourth row shows the character with a dashed line for tracing. The fifth row shows a single horizontal stroke with a dashed line for tracing.

Illustration of a train track with a train. The train is shaped like the character 'お' (o). The train consists of a locomotive (labeled 'だいもん'), a passenger car (labeled 'しんばし'), a dining car (labeled 'つきしじょう'), and a tail car (labeled 'とよす'). The track is labeled 'だいは' (daiha). A conductor is shown with a speech bubble saying 'しゅっぱつ しんこう!' (Shuppatu shinkou!).

Handwriting practice for the character 'お' (o) with stroke order numbers 1, 2, and 3. The character is shown in a light blue color with a dashed line for tracing.



なまえ

お
お
っ
か

大塚

Handwriting practice for the character 'な' (na) on a four-line grid. The first three rows show the character 'な' with stroke order numbers 1, 2, 3, and 4. The fourth row shows a dashed line for stroke 1. The fifth row is empty for practice.

A large illustration of a train track with station names and stroke order numbers. A train conductor character says 'しゅっぱつ しんこう!' (Departure!). The track starts at 'あかばねばし' (Akabane Station) and goes to 'おなりもん' (Onari Station), 'はままつちよう' (Hamamatsu Station), 'しおどめ' (Shiodome Station), 'つきじしじよう' (Tsukishiji Station), 'みた' (Mita Station), 'たけしば' (Takeshiba Station), and 'とうきょう てれぼーと' (Tokyo Teletop). Stroke order numbers 1, 2, 3, and 4 are shown in red.

Handwriting practice for the character 'な' (na) on a four-line grid, showing stroke order numbers 1, 2, 3, and 4.

な
か
の



なまえ

中野

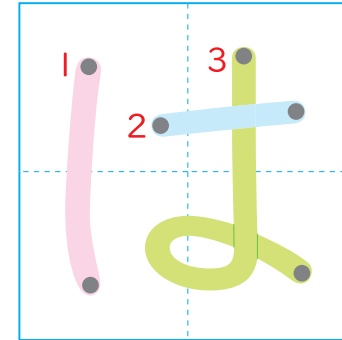
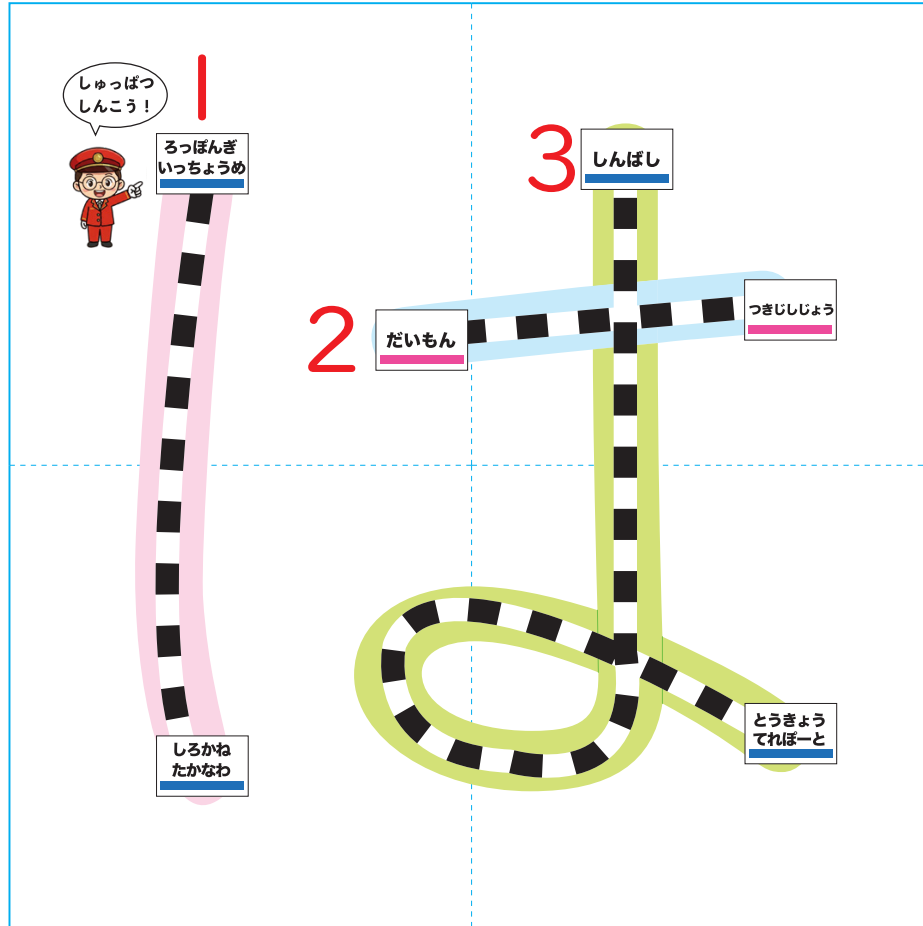
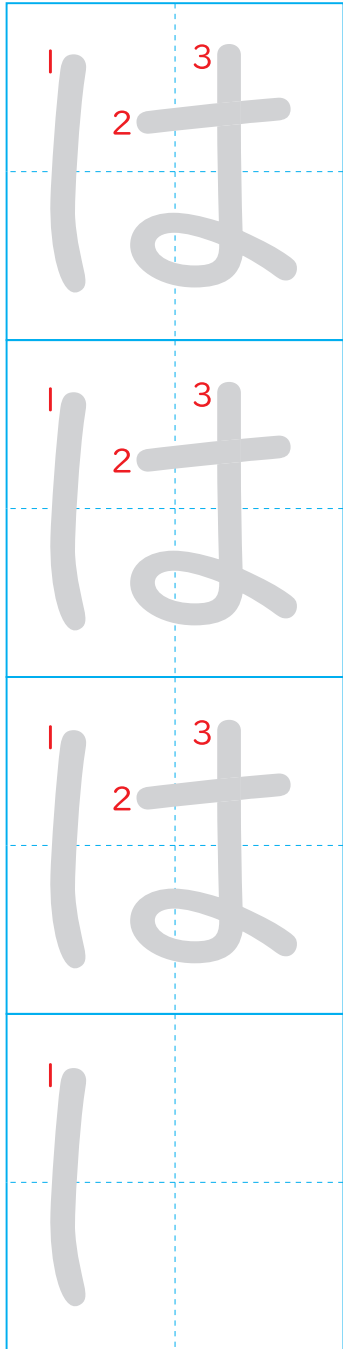

なまえ

は
ら
じ
ゆ
く

原 宿

1 2 4
3 ほ

1 2 4
3 ほ

1 2 4
3 ほ

1 し

しゅっぱつ
しんこう!

1

2 とらのもん

3 だいもん

4

ろっぽんぎ
いっちょうめ

しんぼし

ぎんざ

つきじしじょう

しろかね
たかなわ

とうきょう
てれぼーと

1 2 4
3 ほ

ほう
が



なまえ

保 谷

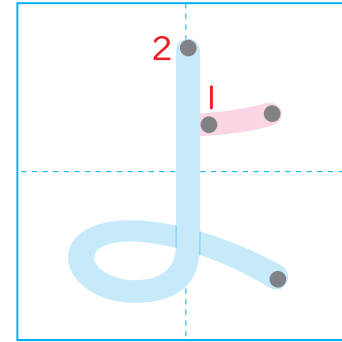
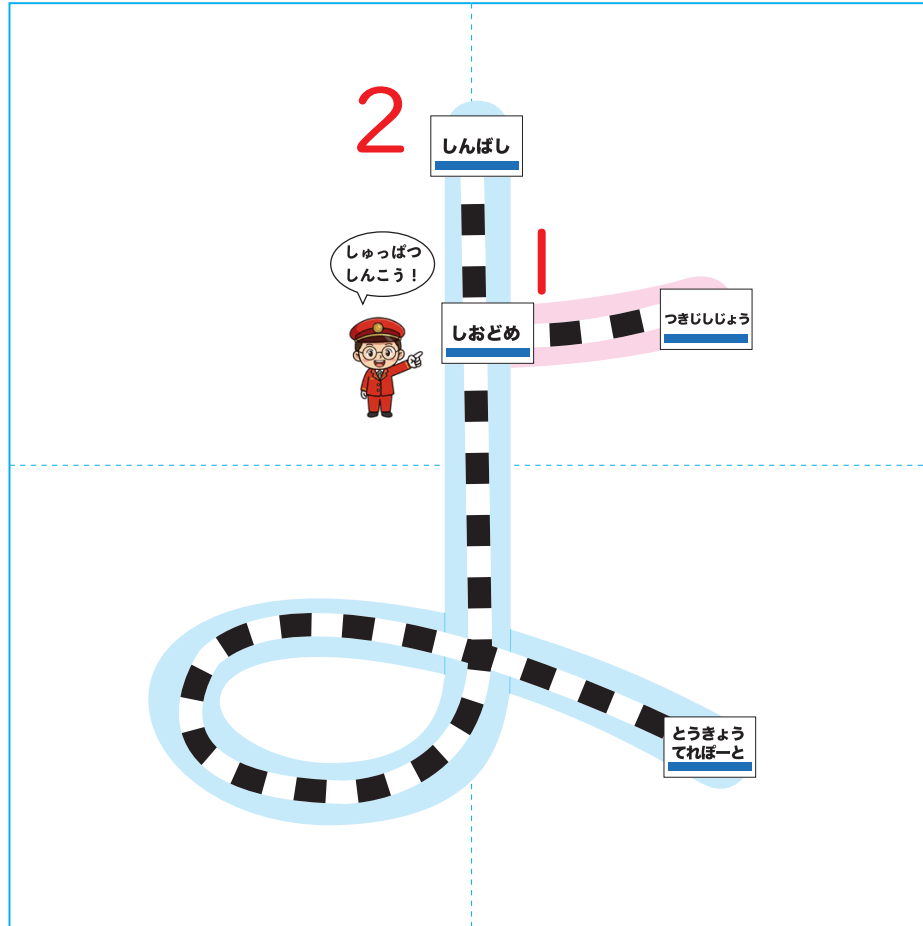
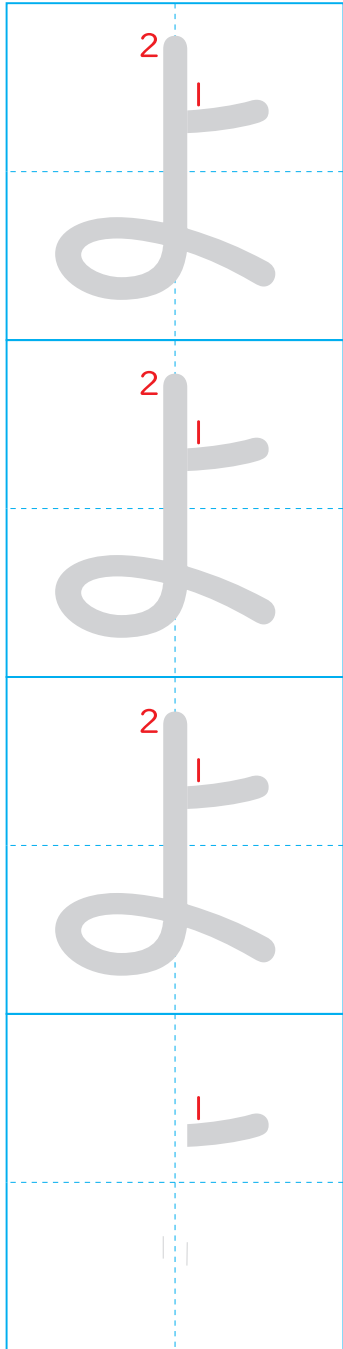

なまえ



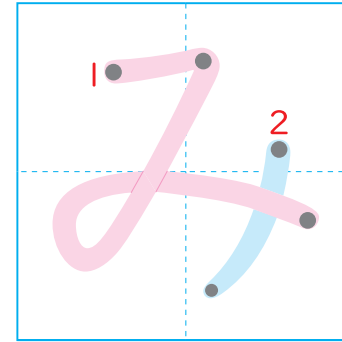
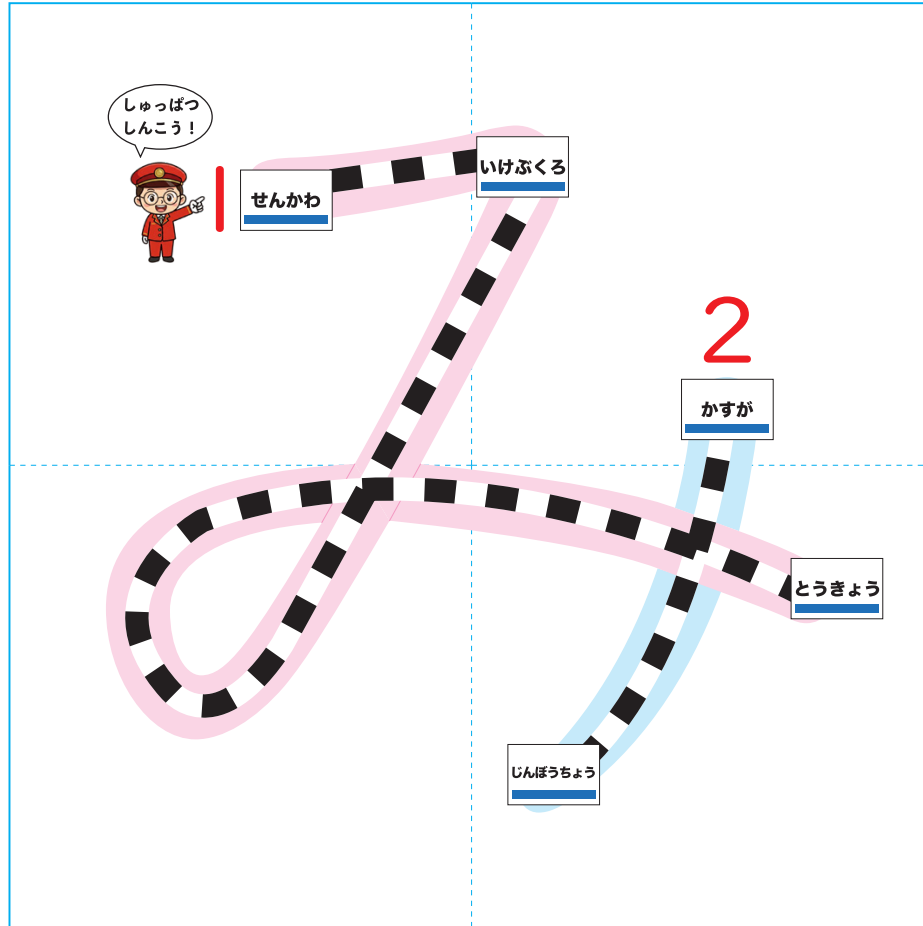
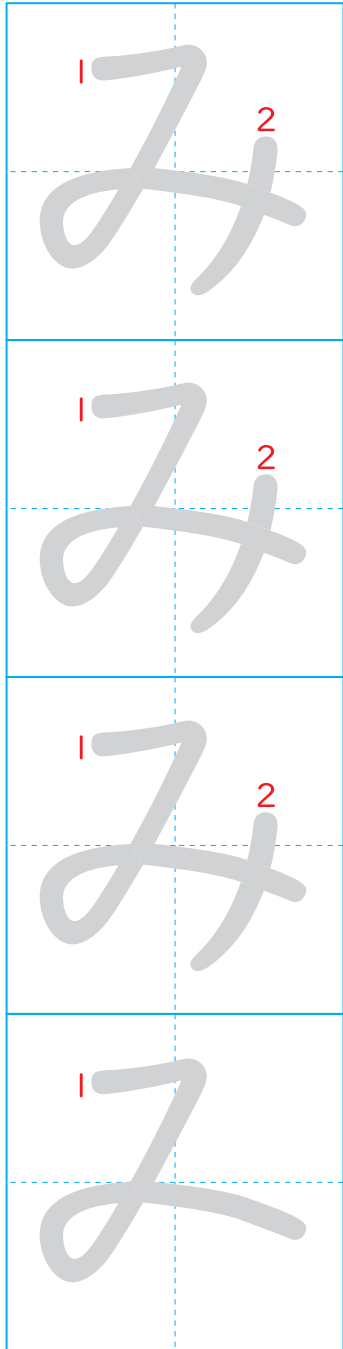

み
た
か



なまえ

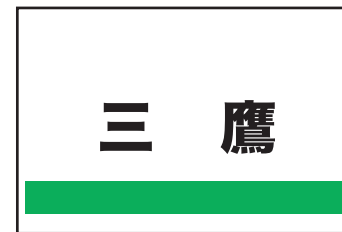

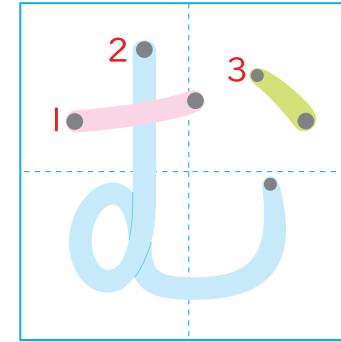
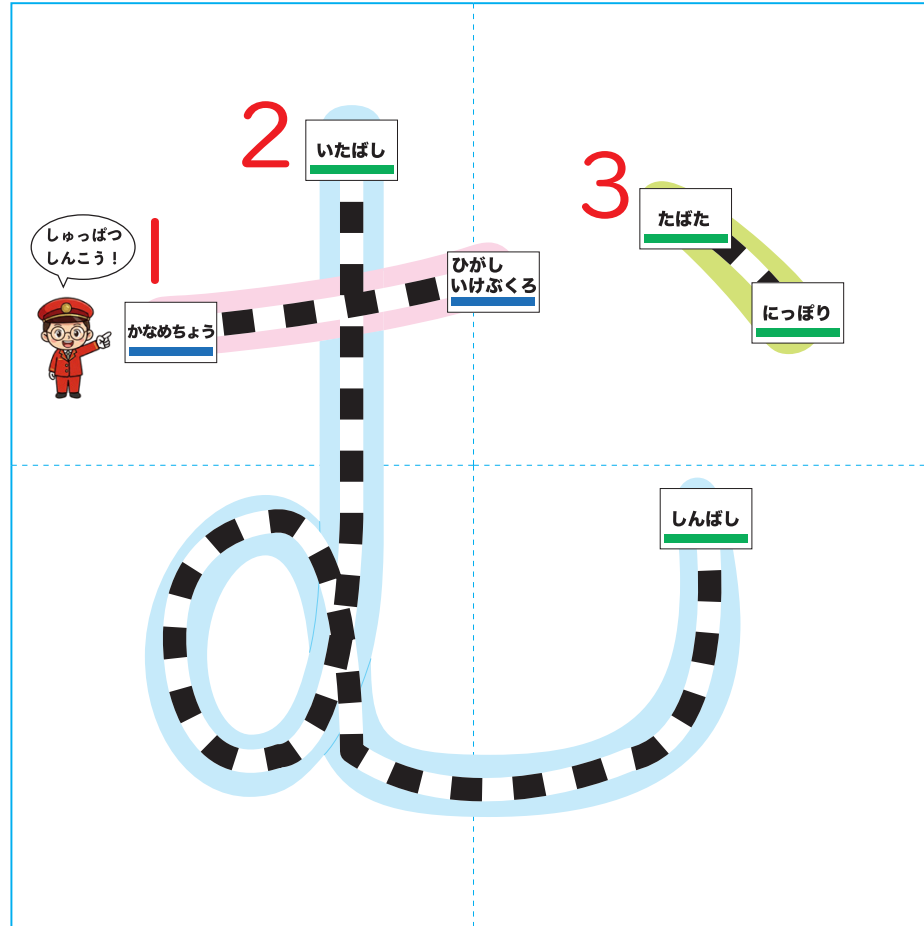
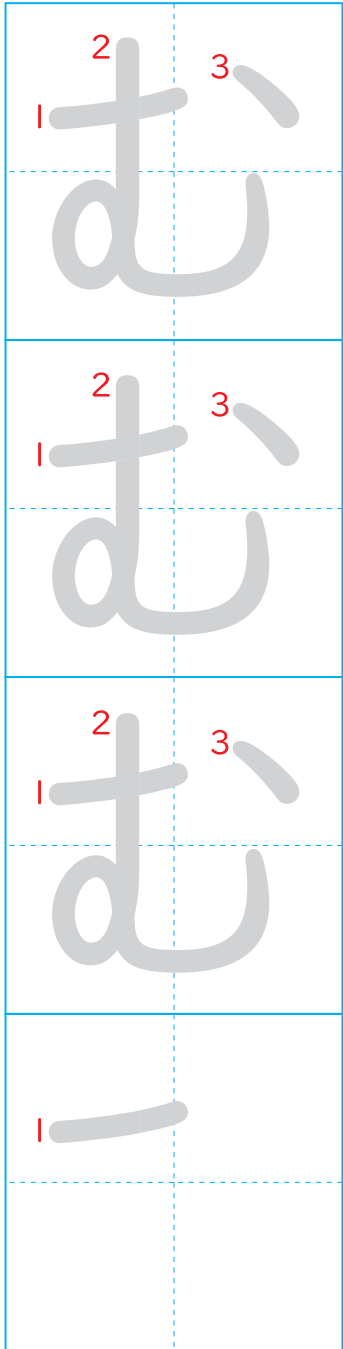

なまえ

むさしむさか

武蔵境

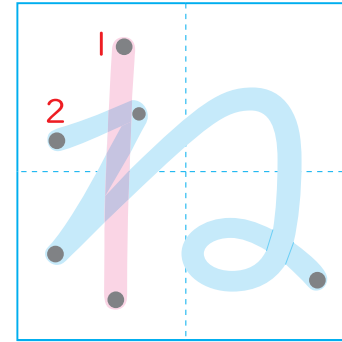
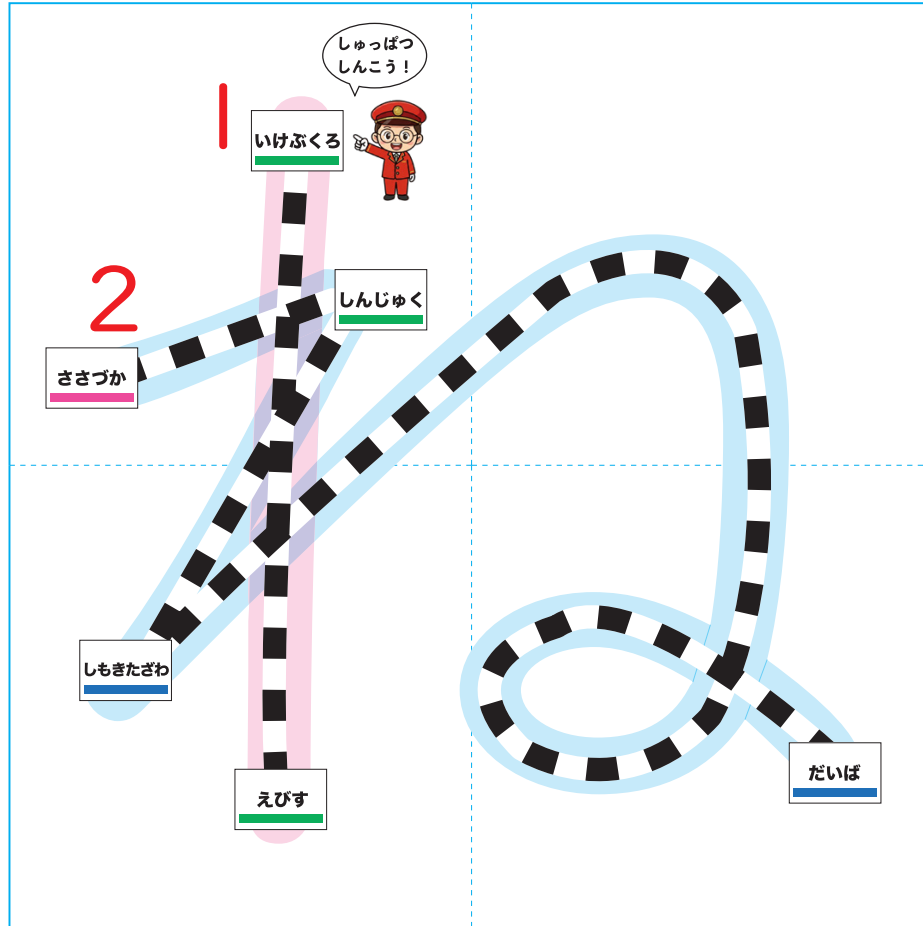
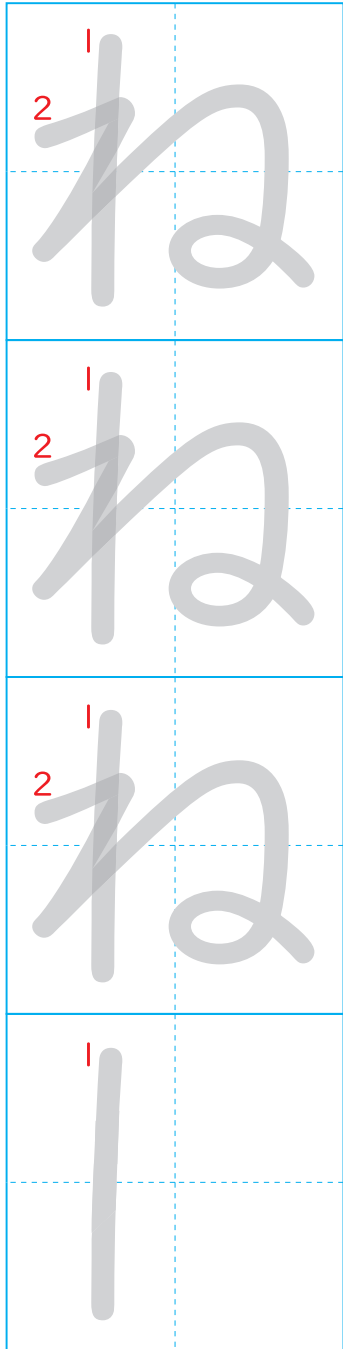

ね
づ



なまえ



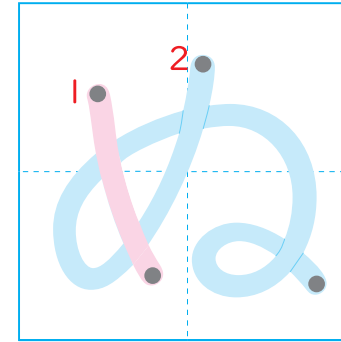
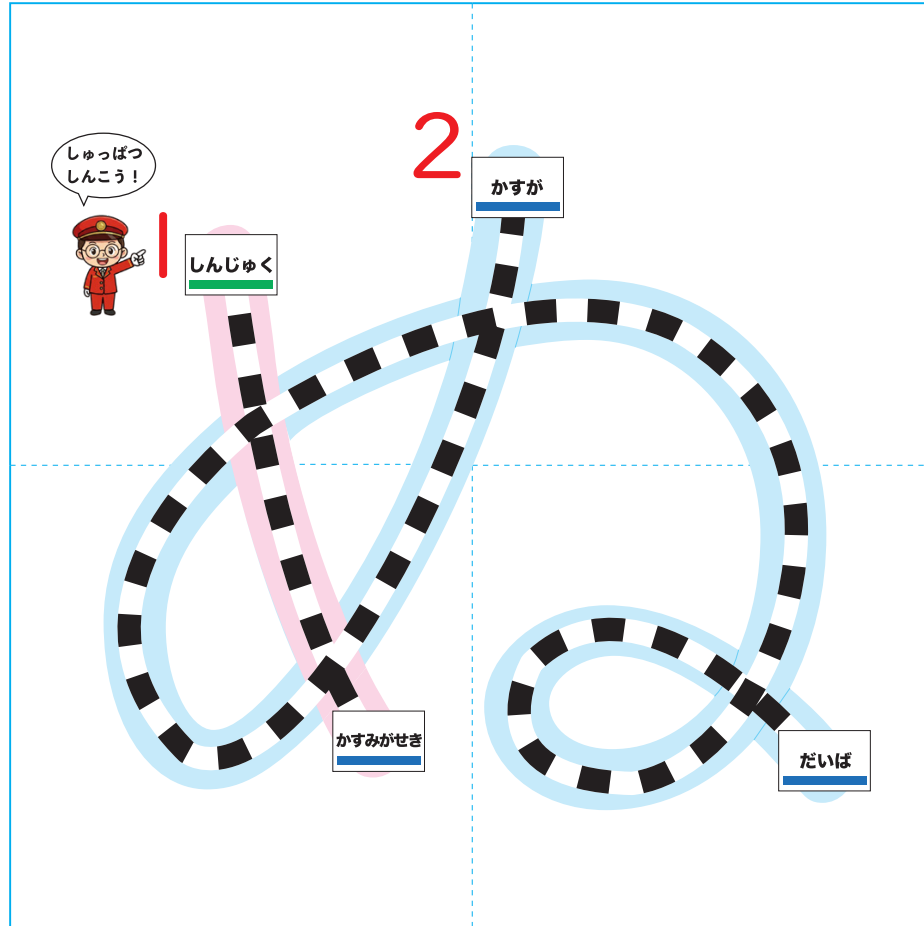
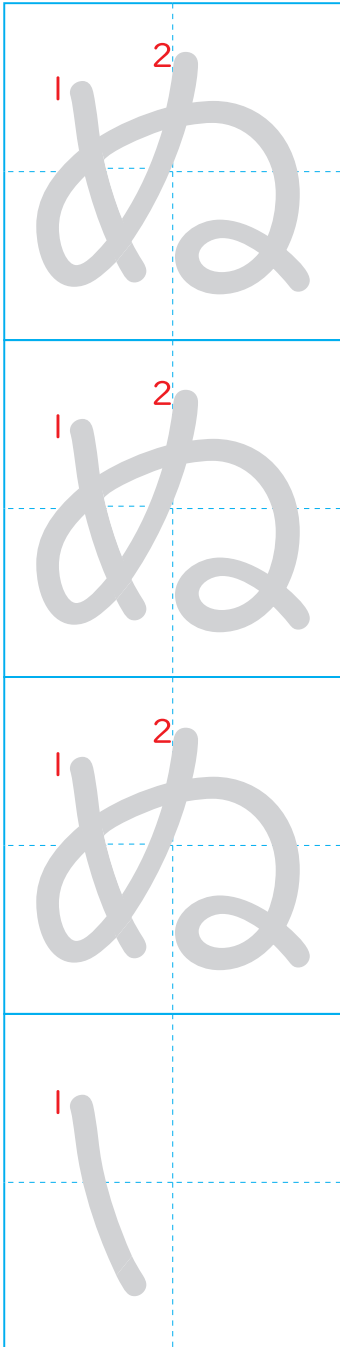

なまえ

ぬ
ま
ぶ
く
ろ

沼 袋

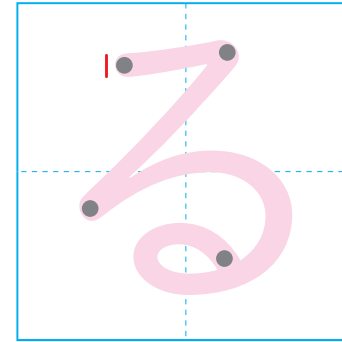
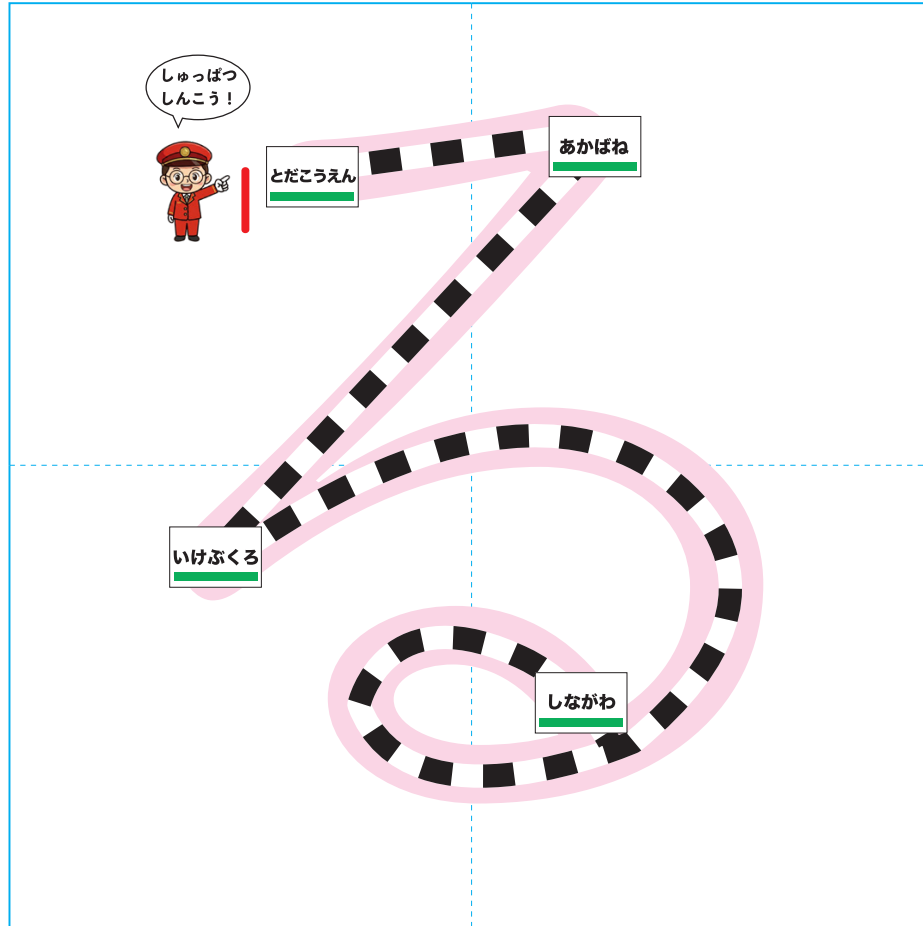
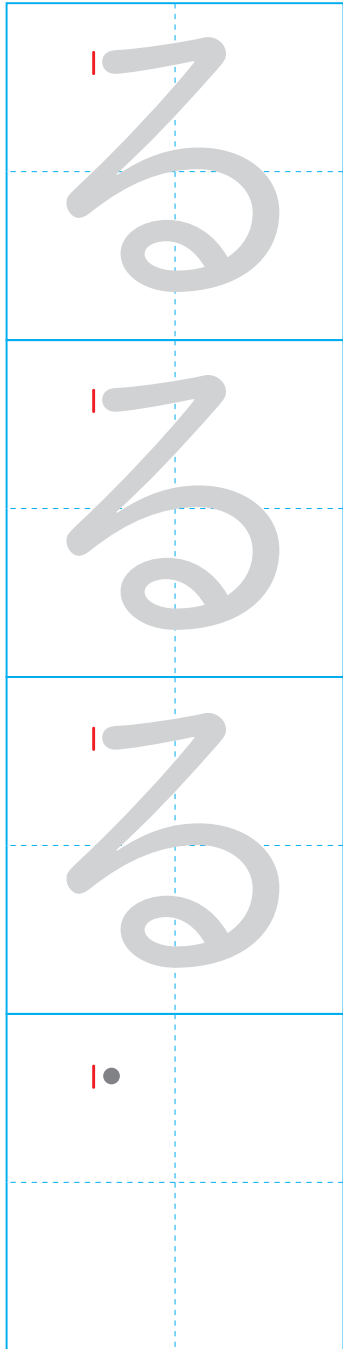

ひ
が
し
く
る
め

東久留米



なまえ

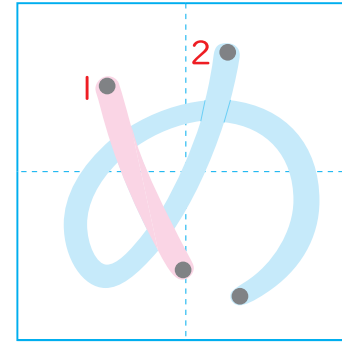
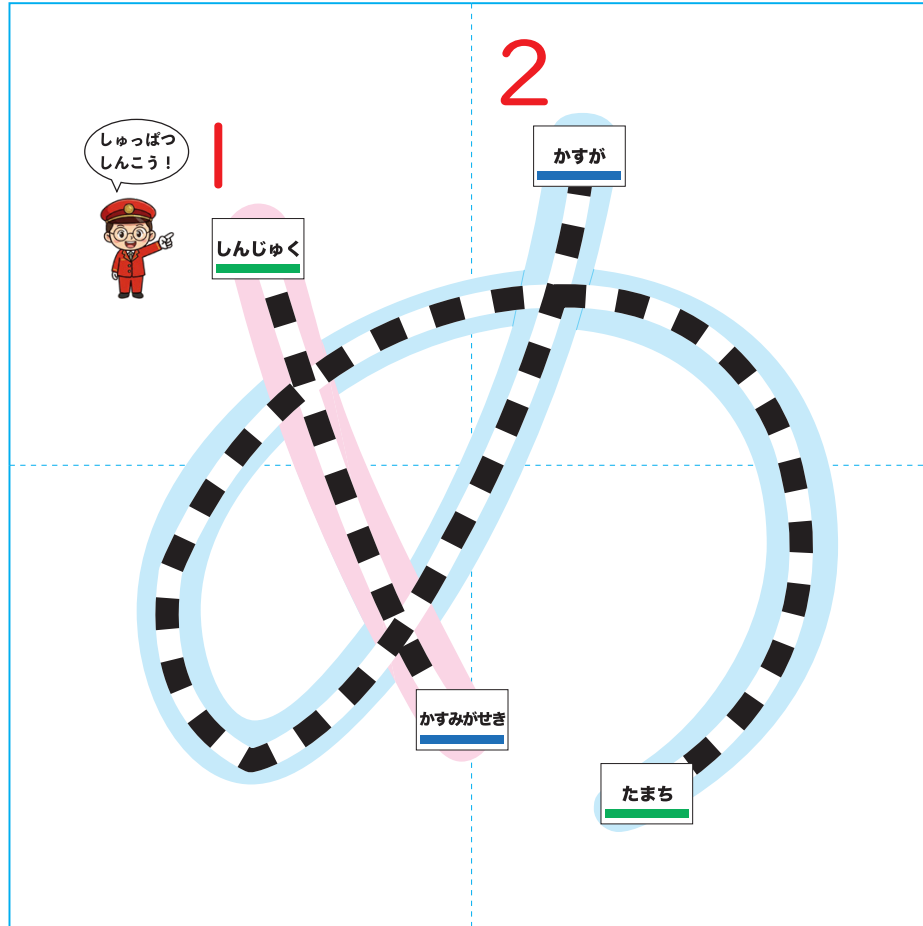
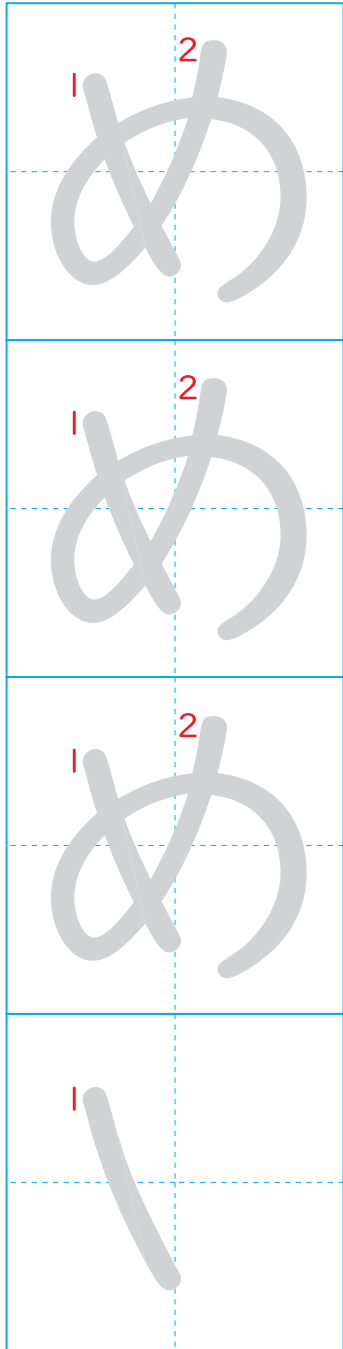

めぐる



なまえ



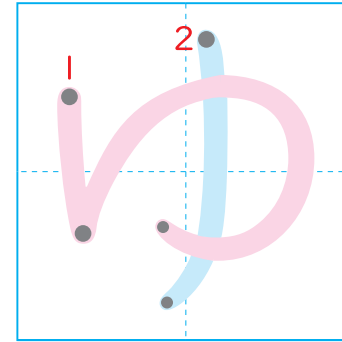
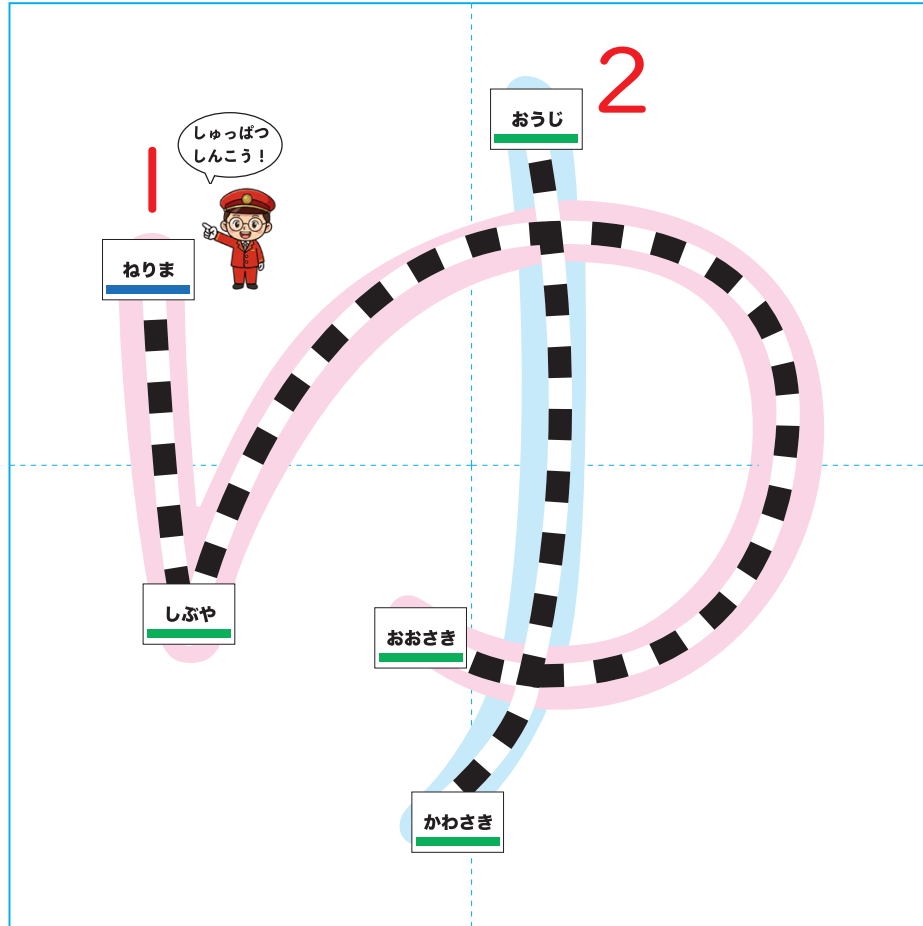
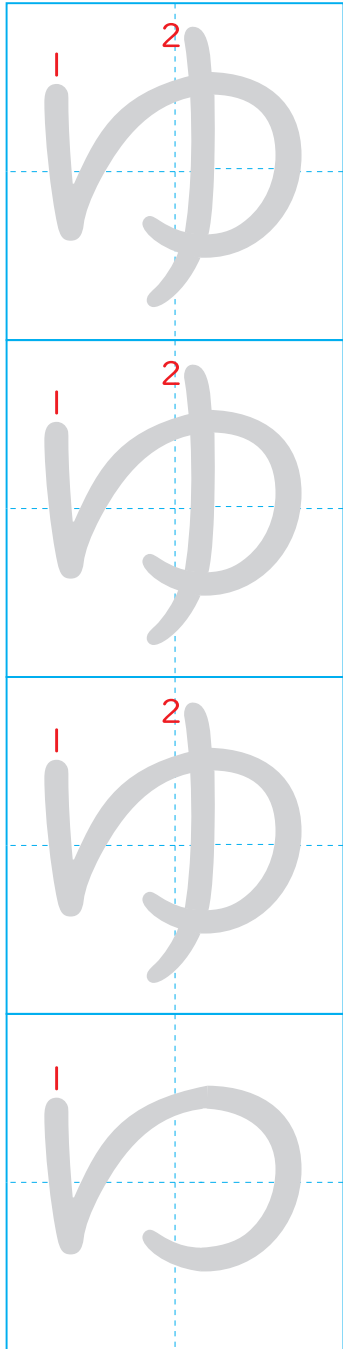

なまえ

ゆ
う
ら
く
ち
よ
う

有楽町

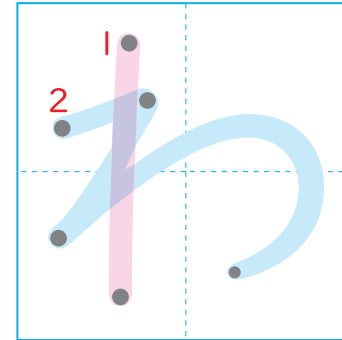
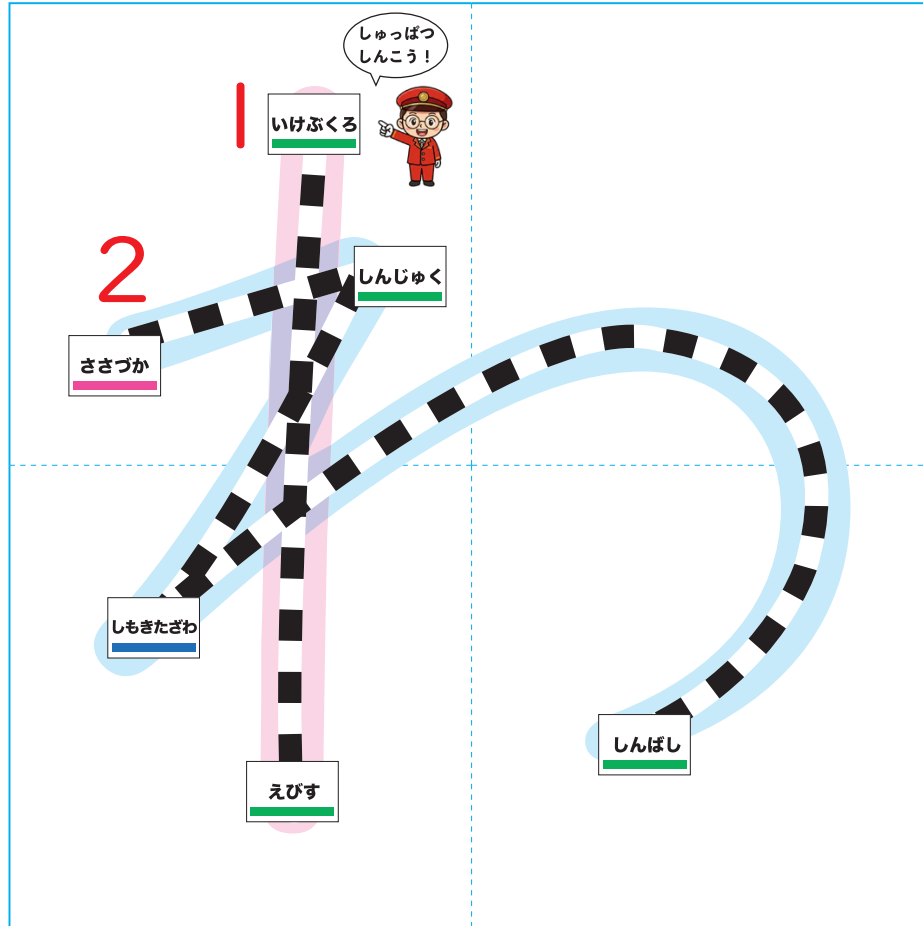
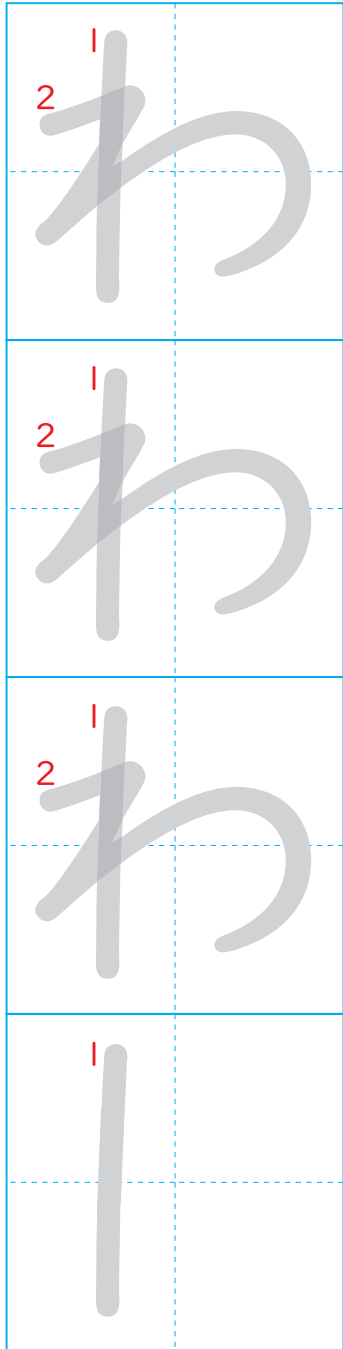

わ
せ
だ



なまえ

早稲田

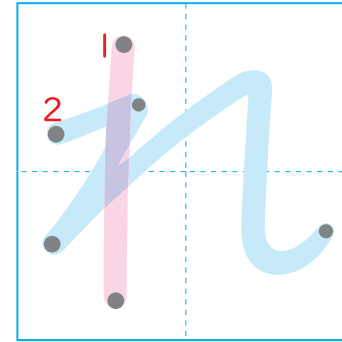
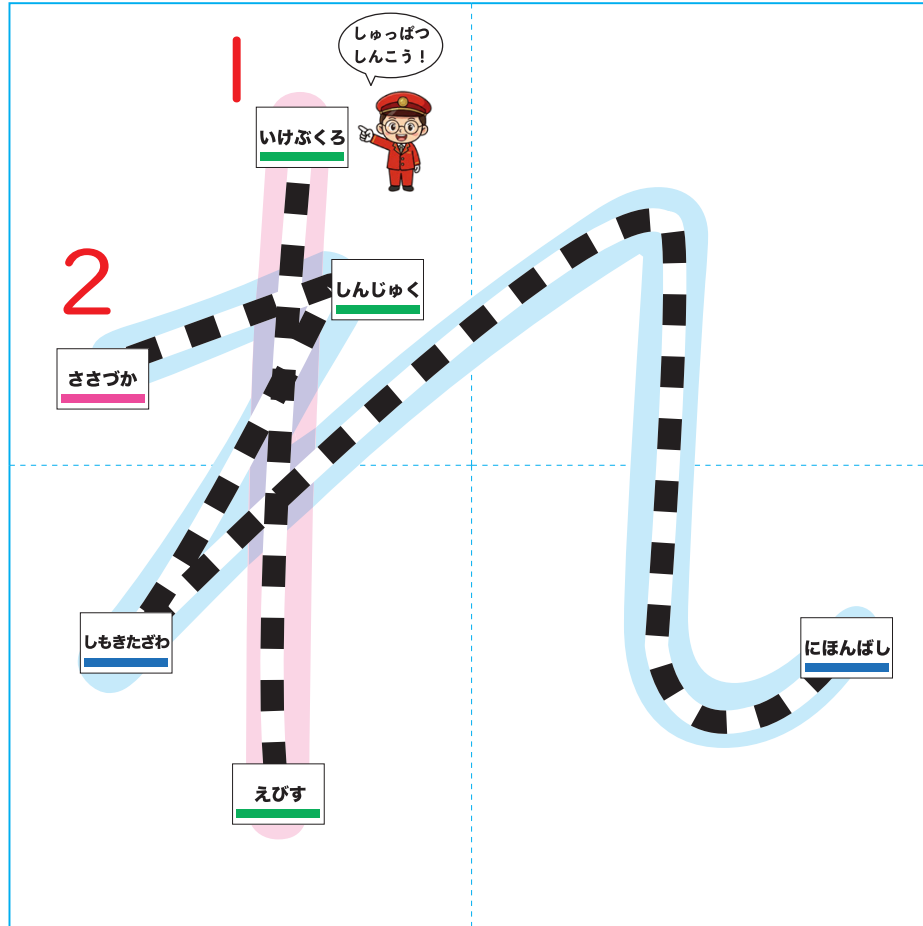
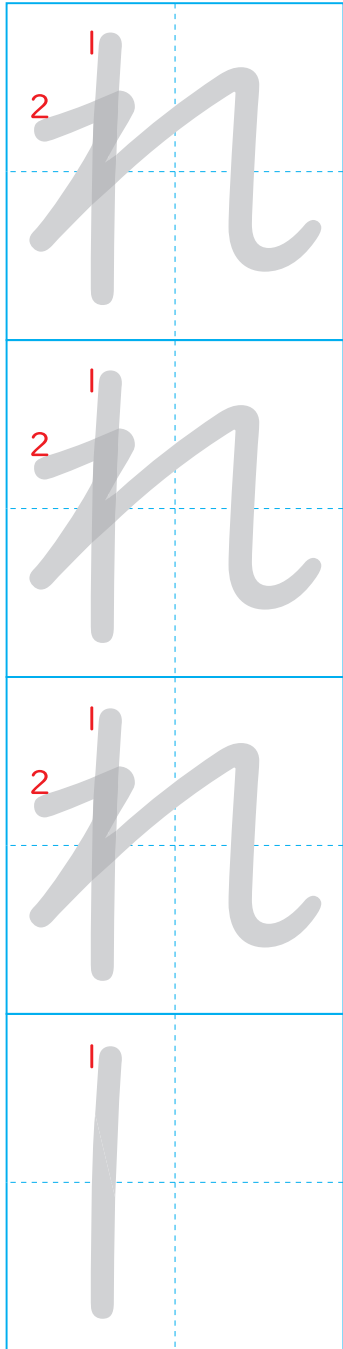

なまえ

どうきょうてれぽーと

東京テレポ-ト

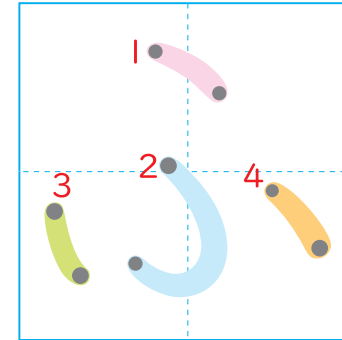
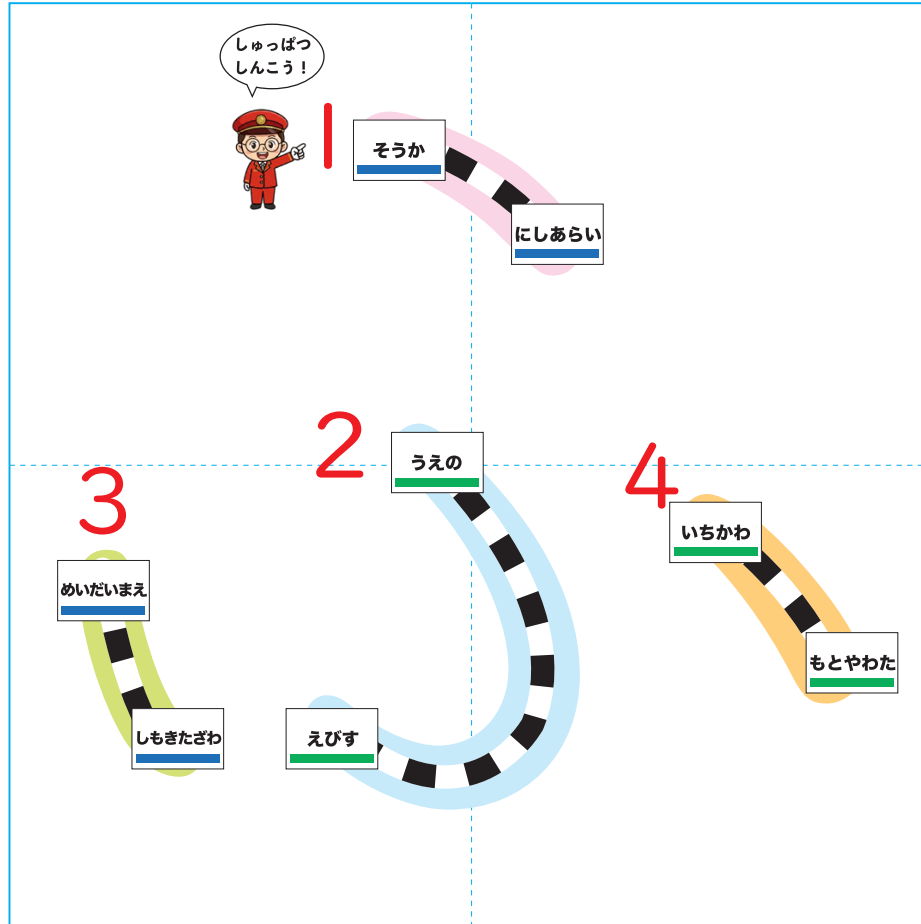
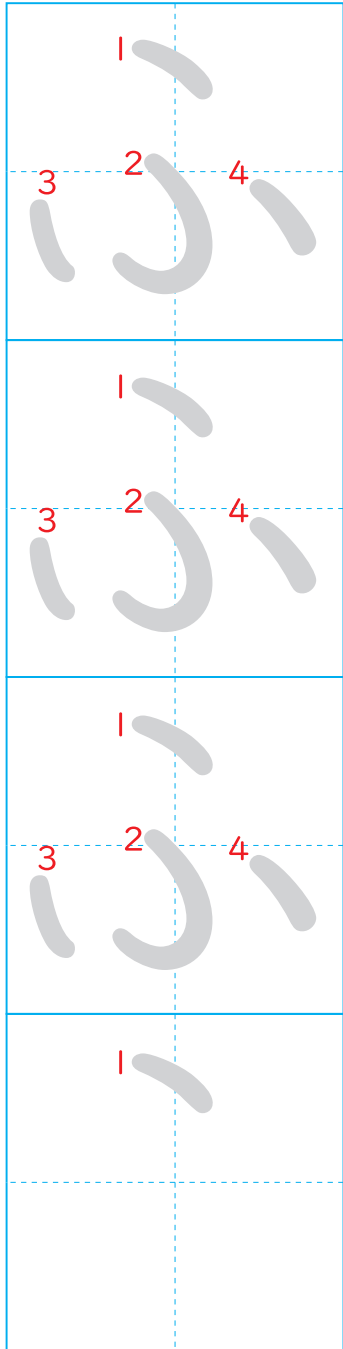

なまえ

ふ
ち
ゆ
う



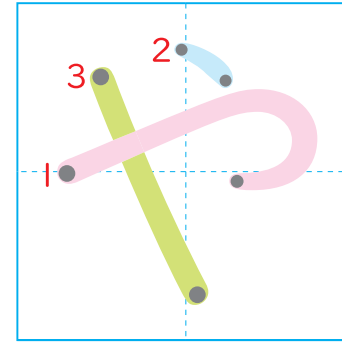
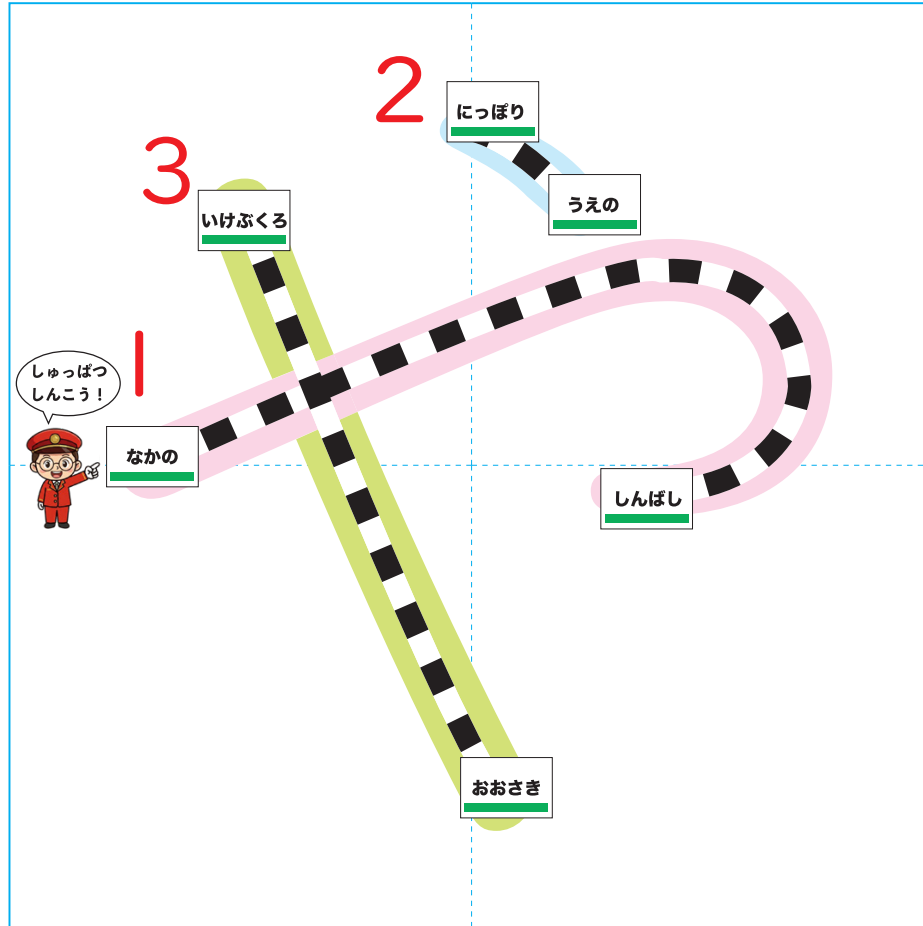
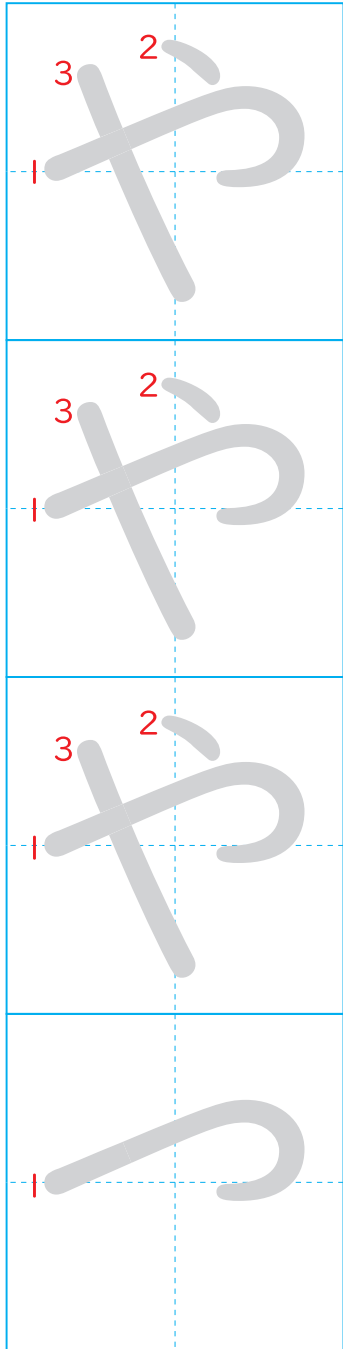

よ
し
や



なまえ

四ツ谷

あ

あ

あ

ー



なまえ

あきはばら

秋葉原

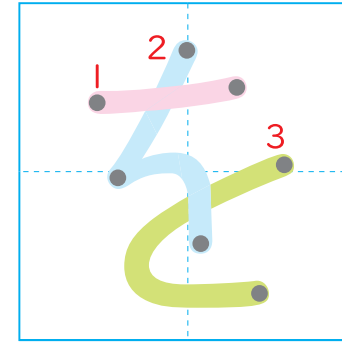
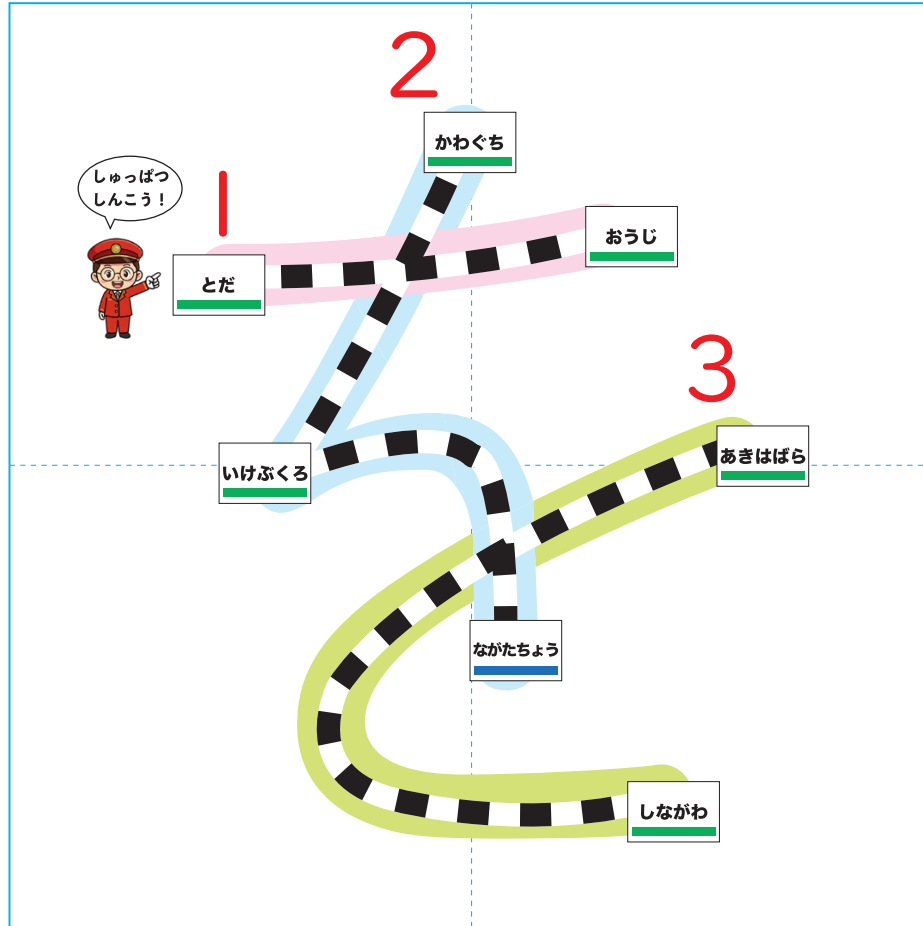
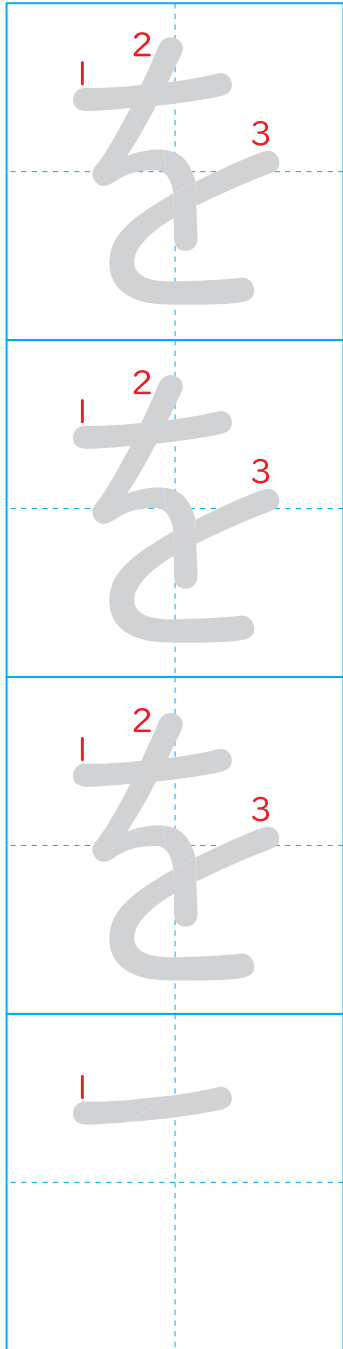

なまえ

でんしゃをみる。